

ICD-08635

POPULAR COMMUNICATIONS

SEPTEMBER 1987 \$2.50
\$3.50 CANADA

Incorporating SCAN Magazine The Official Publication of the Scanner Association of North America

Listening To: Fire Radio Communications!

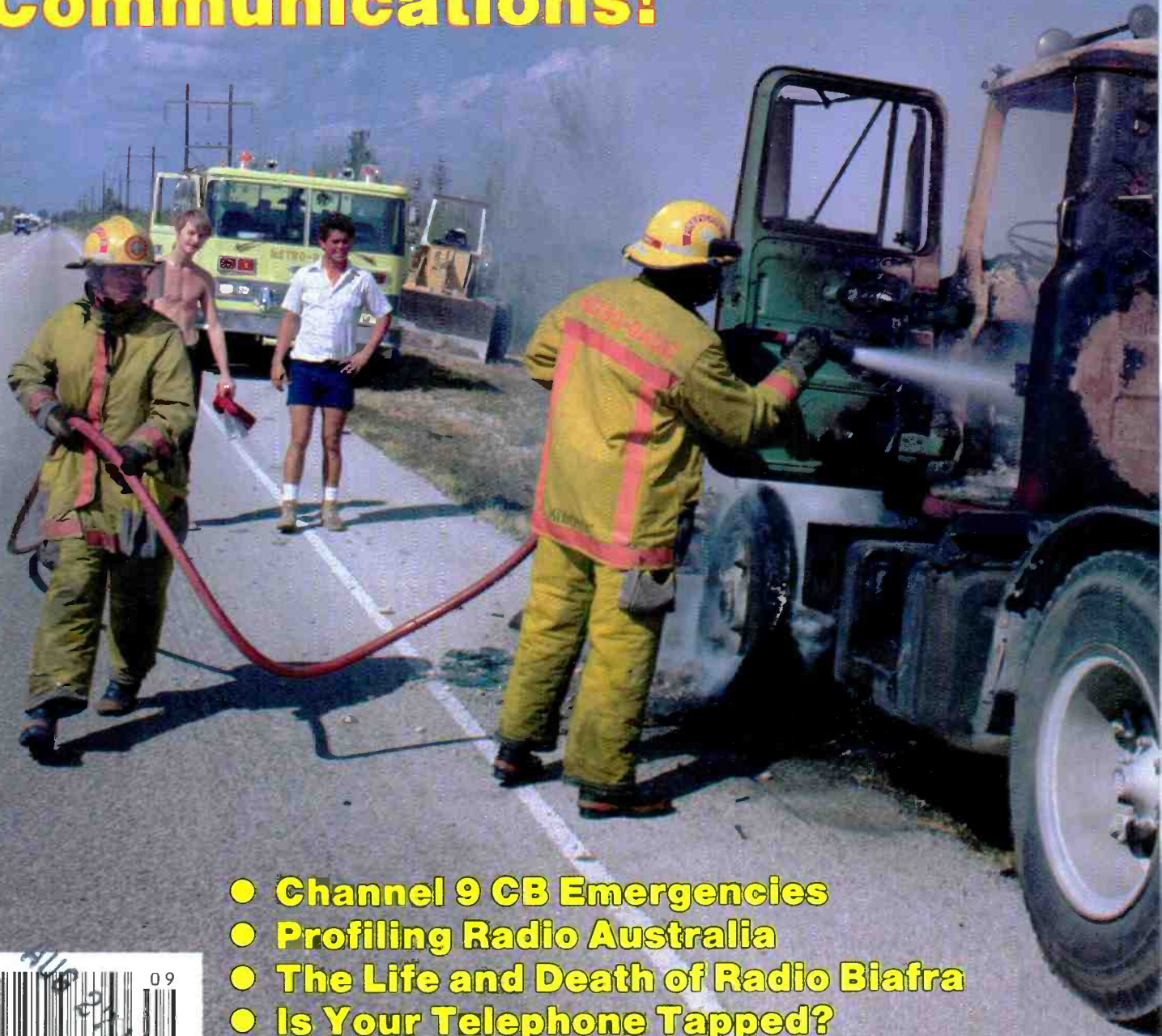

- Channel 9 CB Emergencies
- Profiling Radio Australia
- The Life and Death of Radio Biafra
- Is Your Telephone Tapped?
- Plus: Radio History, Scanners, Shortwave and More!



Uniden

Get Tomorrow's Headlines, Not Yesterday's News.



With a Bearcat® Scanner, You'll be the First to Know

When you're looking for news of the minute instead of news of the day, nothing beats a Bearcat. Uniden Bearcat Scanners deliver the news as fast as it happens. Heart-pounding police and fire runs. Airliners on final approach. Instant updates on hazardous weather.

It's everything you'd expect from Bearcat, the world's best-selling name in scanners. With unmatched quality and reliability from the world leader in radio communications—Uniden.

The Choice of Jack Nicklaus
Winner of 20 Major Golf Championships
©1987 Uniden Corporation of America



uniden®

A New Generation of Communications

CIRCLE 167 ON READER SERVICE CARD

"The Largest Dealer of Scanners in the World"



SCANNER WORLD, USA

10 New Scotland Ave., Albany, NY 12208 518/436-9606



SPECIAL
Regency
MX-3000

Special \$169.99
(\$7.00 shipping)

30 CHANNELS—MOBILE/BASE

Features include simple programming of the following frequency ranges: 30-50 MHz, 144-174 MHz, 440-512 MHz. Digital display, priority, search, lockout, delay, dim control, top mounted speaker, one year factory warranty. Includes AC & DC cords, mobile mounting bracket, telescopic antenna. All for only **\$169.99** plus \$7.00 shipping (optional extended warranty: 3 years \$39.99; 2 years \$29.99.) MX3000 Service Manual \$5.00.

REGENCY HX1500

Digital programmable 55 channel hand-held scanner. Frequency coverage 29-54 MHz, 118-174 MHz, 406-420 MHz, 440-512 MHz. Covers Public Service bands plus aircraft, marine, police, plus many others. Has priority, search, lockout, scan, banks, sealed rubber keyboard, 90 day factory warranty. Includes flexible rubber antenna, belt clip and earphone.

\$234.99 (plus 6.50 shipping each)

Optional Accessories Available for HX-1500:

B-8 Ni-Cad Batteries	15.99
Ma-518 Wal Charger/Adapter	12.99
HX Case Heavy Leather Case	19.99
MA549 Drop-in Charger	89.99
MA257 Cigarette Lighter Adapter	16.99
(3 year extended warranty \$39.99; 2 year \$29.99)	

REGENCY INF-1 Informant Scanner	\$269.99 (7.00)
BEARCAT 70XLT Programmable Hand-Held	174.99 (5.50)
BEARCAT 50XL Programmable Hand-Held	124.99 (5.00)
AD100U AC Adapter/Charger for 50 XL	12.95 ()
3P55 Ni-Cad Battery Pack for 50XL	13.99 ()
CA50 Carry Case for 50XL	11.99 ()
PS001 Cigarette Lighter Adapter for 50XL/100XL	12.95 ()
BEARCAT 140 AC Programmable Scanner	94.99 (5.00)
BEARCAT 145XL AC Programmable Scanner	99.99 (5.00)
BEARCAT 175XL AC Digital Scanner	159.99 (5.00)
BEARCAT 100XL Digital Hand-held	199.99 (6.50)
BEARCAT 200 AC Digital Scanner	129.99 (6.50)
BEARCAT Weather Alert	39.99 (4.00)
BEARCAT 210XLT AC/DC Digital Scanner	199.99 (7.00)
BEARCAT 800 XLT AC/DC Digital Scanner	299.99 (7.00)
REGENCY R1075 AC Digital Scanner	104.99 (5.00)
REGENCY MA-257 Cigarette cord for HX1000/1200	16.99 ()
REGENCY MA-917 Ni-cad Battery for HX1000/1200	24.99 ()
REGENCY HX-CASE Hvy Leath. case for HX1000/1200	19.99 ()
REGENCY MA-549 Drop in charger for HX1000/1200	89.99 (5.00)
REGENCY HX-2000 Digital Hand Held	159.99 (7.00)
REGENCY MX-3000 AC/DC Digital Scanner	169.99 (7.00)
REGENCY HX-2200 Digital Hand-Held Scanner	172.99 (7.00)
REGENCY MX-4200 AC/DC Digital Scanner	186.99 (7.00)
REGENCY Z-30 AC/DC Digital Scanner	129.99 (5.50)
REGENCY Z-60 AC/DC Digital Scanner	189.99 (5.50)
Mobile Mounting Bracket for Z Scanners	5.99 ()
REGENCY ACT-R-1 AC/DC Crys. Single Channel	75.99 (4.00)
REGENCY RH-256 High Band Transceiver	359.99 (7.75)
REGENCY HC 102 Hi-VHF Hand Transceiver	119.99 (5.50)
REGENCY RU150B UHF Transceiver	439.99 (7.75)
REGENCY RH-600B High Band Transceiver	429.99 (7.75)
REGENCY RB06 AC/DC Crystal Scanner	79.99 (5.00)
COBRA SR-2 Digital Hand-Held Scanner	199.99 (5.00)
COBRA SR-0 Digital Hand-Held Scanner	129.99 (6.00)
COBRA SR090 AC/DC Digital Scanner	109.99 (5.00)
COBRA SR225 AC/DC Digital Scanner	164.99 (6.00)
Book "Top Secret Registry of Gov't Frequency"	29.99 (3.00)
Book "Covert Intelligence, Electronic Eavesdropping"	8.95 ()
Book "Betty Bearcat Frequency Directory"	14.95 ()
Book "Rail Scan Directory"	7.95 ()
Book "Air Scan Directory"	12.95 ()
QCD MRP-1 Single Channel Hand-Held	38.99 (3.00)
FANON M8-1LU DC Crystal Scanner	99.99 (5.00)
FANON PSK-1 AC Adapted for MBLLU	12.99 ()
FOX BMP-1060 AC/DC Digital Scanner	129.99 (5.50)
FOX Mounting Bracket for BMP-1060	9.99 ()
ANT-1 Magret Mount Mobile Scanner Antenna	29.99 (3.00)
ANT-6 Base Scanner Antenna w/50' cable	29.99 (3.00)

Scanner World Special

\$129.99

(plus \$5.50 shipping each)

Optional Accessories:

Cigarette Lighter Plug RGMP.C	\$4.95
Z Mobile Bracket — Special	\$5.99

home or on the road. It is double conversion, super heterodyne used to receive the narrow band FM communications in the amateur, public safety and business bands: 30-50, 144-174, and 440-512 MHz. Size 10 3/4" W x 2 7/8" H x 8 3/8" D.

Sophisticated microprocess-controlled circuitry eliminates the need for crystals, instead, the frequency for each channel is programmed through the numbered keyboard similar to the one used on a telephone. A "beep" acknowledges contact each time a key is touched. The Z30 scans approximately 15 channels per second.

Any combination of two to thirty channels can be scanned automatically, or the unit can be set on manual for continuous monitoring of any one channel. In addition, the search function locates unknown frequencies within a band.

Other features include scan delay, priority and a bright/dim switch to control the brightness of the 9-digit Vacuum-Fluorescent display. The Z30 can be operated on either 120 VAC or 12 VDC. Includes one year warranty from Regency Electronics (optional 3 yr extended warranty only \$39.99, gives you a total of 4 yrs complete warranty or 2 yr extended warranty only \$29.99, gives you a total of 3 yrs complete warranty.) Z-30 Service Manual \$5.00.

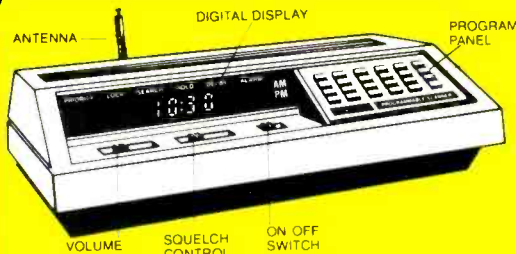

The Regency Z30 is a compact, programmable 30 channel, multi band, FM monitor receiver for use at



\$172.99

(Plus \$7.00 shipping each)

Digital Programmable 20 Channel Hand-Held Scanner with raised button keyboard for easy programming of the following frequency ranges: 118-136 MHz, 138-174 MHz, 406-512 MHz, 800-950 MHz (NOTE: This is the only hand-held portable scanner which will receive the 800-950 MHz range plus high band, air, and UHF). Features include priority, scan delay, memory backup, dual scan speed, channel lockout, jacks for external antenna and earphone, 90 day factory warranty, keyboard lockswitch, sidelit liquid crystal display for night use, program AM or FM mode, search or scan, size is 3" x 7" x 1 1/2". Complete HX2200 package includes Ni-Cad rechargeable batteries, wall charger adapter, protective carry case, and rubber antenna. All for the low price of only \$172.99 plus \$7.00 shipping each. (Optional extended warranty: 3 years \$39.99, or 2 years \$29.99)



Bearcat 100 XL

\$199.99 (6.50 shipping) Handheld digital programmable, no crystal portable scanner. 16 channels, search feature, plus more! Frequency range: 30-50, 118-174, 406-512 MHz. Included in the package is a flexible rubber antenna, earphone battery charger/AC adapter, 6 AA Ni-Cad rechargeable batteries and a heavy duty carry case. All for the low price of

\$199.99 (6.50 shipping)

(3 year extended warranty only \$39.99, 2 year \$29.99)

REGENCY RH-256 B PROGRAMMABLE TRANSCEIVER

RH-256B Transceiver, 16 channel 12 VDC 2-way Radio fully programmable in transmit and receive mode. Includes built-in CTCSS tones for encode/decode, time-out timer, scan delay, 25 watts transmit power, priority, plus more. Frequency spread as shipped 152-158 MHz. Package includes mobile mike, bracket, mobile antenna, and all cables and instructions for installation. **Special package deal only: \$359.99** (7.75 shipping) (2 year extended warranty \$49.99 - 3 year \$69.99)

ORDERING INFORMATION

Call (518) 436-9606 to place orders by phone or mail orders to **Scanner World**, 10 New Scotland Ave., Albany, NY 12208. Orders will be shipped same day received by United Parcel Service. **Scanner World** accepts VISA, MasterCard (COD shipments by United Parcel will be for cash or certified checks only). Mail orders with personal or business checks will be held 4 weeks for bank clearance. Orders with cashiers checks or money orders shipped same day received. Prices, specifications and terms subject to change without prior notice. If items are out of stock we will backorder and notify you of delivery date. All shipments are F.O.B. **Scanner World** warehouse in Albany, NY. We are not responsible for typographical errors. All merchandise carries full manufacturers warranty. Bid Proposals and Purchase orders accepted from Government agencies. Free full line catalogue available upon request. No minimum order. New York State Residents add 7% sales tax.

SHIPPING CHARGES

(* Add \$) per scanner, and \$3.00* for all accessories ordered at same time. C.O.D. shipments will be charged an additional \$3.00 per package. Full insurance is included in shipping charges. All orders are shipped by United Parcel Service. Shipping charges are for continental USA only. Outside of continental USA, ask for shipping charge per scanner.

Scanner World, USA

10 New Scotland Ave., Albany, NY 12208

(518) 436-9606

Most orders Shipped Same Day Received!



Available September 1987

- 100 channels in five banks of 20 each
- 29-54 MHz; 118-174 MHz; 406-512 MHz
- Automatic search of pre-programmed aircraft, police, emergency, marine, and weather frequencies.
- Optional receive preamplifier
- Optional programmable CTCSS tone board.
- Orange backlit LCD display

CALL FOR LOW PRICE

Scanner World, USA • Albany, New York 12208 • (518) 436-9606

Scanner World, USA • 10 New Scotland Ave. • Albany, New York 12208 • (518) 436-9606

POPULAR COMMUNICATIONS

Now Incorporating
SCAN Magazine

SEPTEMBER 1987

VOL. 6, NO.1



10



14



16

FEATURES

Scanning Today

War over FCC rulemaking 5836 heats up.

by Robert A. Hanson

8

Station Profile: Radio Australia

Darwin and Carnarvon.

by Dr. Adrian Peterson

10

POP'COMM Scans: The Fire Radio Service

High-intensity excitement from this low-profile service.

by Rick Maslau, KNY2GL

14

Radio's Rousing Days

Don't touch that dial! Stay tuned for a report on radio's roots.

by Alice Brannigan

16

A Revolutionary New Concept in Scanners

The Regency Informant Mobile Scanner provides completely "hands-free" monitoring.

by F.X.F., North Dakota

20

Books You'll Like

Start the school year off right with: *Clandestine Radio Broadcasting; So You Bought a Shortwave Radiol!*; *Utility QSL Address Guide, Volume 1*.

by R.L. Slattery

24

The Life and Death of Radio Biafra

by Don Jensen

26

CB Channel 9 Emergency Communications

Pressing a mic button brings instant aid.

by Jack Elliot

29

SCAN Public Service Award

Two dispatchers aid in lifesaving effort.

37

SCAN Photo Contest Winners

Is your shack as well-equipped and good looking as these?

37

This month's cover: The Miami Florida Fire Department puts out truck fire. Photo by Larry Mulvehill, WB2ZPI.

DEPARTMENTS

Beaming In	4	Scanner Scene	52
Mailbag	6	Pirates Den	54
Emergency	30	CB Scene	58
Satellite View	32	Broadcast Topix	60
Better Signals	34	Communications Confidential	63
The Ham Column	40	Listening Post	68
POP'COMM Products	42	Radar Reflections	71
RTTY	44	Clandestine Communique	72
On The Line	50	Communications Shop	74

EDITORIAL STAFF

Tom Kneitel, K2AES/ZF2JO
Editor

Elisa Nudelman
Associate Editor

CONTRIBUTING EDITORS

Gerry L. Dexter
Shortwave Broadcast

Robert Margolis

RTTY Monitoring

Gordon West, WB6NOA

Emergency Communications

Don Schimmel

Utility Communications

Edward Teach

Alternative Radio

Harold A. Ort, Jr.

Military Consultant

Janice Lee

Radar Detectors

Chuck Gysi, N2DUP

Scanners

Julian Macassey, N6ARE

Telephone Accessories

Mark J. Manucy, W3GMG

AM/FM Broadcasts

Ed Noll, W3FQJ

Antennas

Donald Dickerson, N9CUE

Satellites

Dave Newkirk, AK7M

Amateur Radio

BUSINESS STAFF

Richard A. Ross, K2MGA

Publisher

Jim Gray, W1XU

Advertising Manager

Dorothy Kehrwieler

General Manager

Frank V. Fuzia

Controller

Arlene Caggiano

Accounting

Melissa Kehrwieler

Subscriber Services

PRODUCTION STAFF

Elizabeth Ryan

Art Director

Barbara Scully

Artist

Dorothy Kehrwieler

Production Manager

Pat Le Blanc

Florence V. Martin

Phototypographers

Hal Keith

Technical Illustrator

Larry Mulvehill, WB2ZPI

Contributing Photographer

Offices: 76 North Broadway, Hicksville, NY 11801. Telephone 516 681-2922. Popular Communications (ISSN 0733-3315) is published monthly by Popular Communications, Inc. Corporate officers: Richard A. Ross, Pres.; Thomas S. Kneitel, Vice Pres.; Alan M. Dorhoffer, Secretary. Second class postage paid at Hicksville, NY and additional offices. Subscription prices: Domestic—one year \$16.00, two years \$31.00, three years \$46.00. Canada/Mexico—one year \$20.00, two years \$39.00, three years \$58.00. Foreign—one year \$22.00, two years \$43.00, three years \$64.00. Foreign Air Mail—one year \$75.00, two years \$149.00, three years \$223.00. Entire contents copyright ©1987 by Popular Communications, Inc. Popular Communications assumes no responsibility for unsolicited manuscripts, photographs, or drawings. Allow six weeks for change of address or delivery of first issue. Printed in the United States of America. Postmaster: Please send change of address to Popular Communications, 76 North Broadway, Hicksville, NY 11801.



Introducing scanners from the name that needs no introduction.

Cobra.

You've seen it on state-of-the-art CB radios, radar detectors, corded and cordless telephones and answering systems.

And now, Cobra excellence in personal communications systems comes to scanners.

With not just one model. But four different units, all equipped with the latest in user-friendly features including crystal-free, multi-band electronic digital tuning.

No matter which model your customers select, the top-of-the-line hand-held SR-12 with 16 programmable channels or the 10-channel SR-10; Cobra's premium desk-top SR-925 with 16 channels or the SR-900—they'll be getting the very same Cobra quality and service that comes from 25 years in personal consumer electronics.

Contact your Cobra distributor or Cobra directly.

And get all the scoop much too long to scan here.



CIRCLE 12 ON READER SERVICE CARD

Cobra Consumer Electronics Group, 6500 W. Cortland, Chicago, IL 6063

Heading Towards Number Six!

This issue of *POP'COMM* marks the beginning of our sixth year of publication. It certainly has gone by very quickly; seems as though it was only yesterday that Dick Ross and I sat down and thrashed over what the new magazine was going to be and how it would look.

Getting out the first issue was an exercise in high adventure. A couple of authors I wanted for columnists turned out to be unavailable, and one or two who signed-on submitted manuscripts that weren't what I wanted. But even before the September '82 issue was ready for the printer, the word had gotten out that it was on the way and we began to receive inquiries for subscription information.

SWL clubs had a mixed reaction to our expected arrival on the scene. Several clubs quickly wrote to offer their support and wishes for our success, others commented in their newsletters how they had seen monitoring magazines show up and fold up practically simultaneously. They suggested to their members that a "wait and see" approach might be prudent, under the circumstances. Probably the most enthusiastic SWL club was the *American Shortwave Listeners Club (ASWLC)*; they asked us to send a batch of subscription blanks so that they may include them with literature that they sent to prospective members. We happily obliged!

An especially warm reception to word of the forthcoming magazine came from many good folks who were avid readers of the magazine I had edited prior to *POP'COMM*. The owners of that magazine had turned it over to new owners in Oklahoma; I didn't continue my association with the magazine after the ownership change. Some six months had passed without any word given to the readers as to what was going on; they feared that I had fallen off the farthest edge of the world.

By the time the first issue rolled off the presses and went into distribution, we had already racked up a surprisingly large number of subscribers. These were people who ordered the magazine without ever having seen a single issue. This was taken as a very good omen.

The premier edition sold exceedingly well on the newsstands, even better than we had dared to hope for. The mail was most encouraging. There wasn't any shortage of letters suggesting things that we should have included but didn't, or did cover but shouldn't have. Even the one really sour grapes reaction to our early issues was a plus. It came from a chap who issues a drab little shortwave broadcasting DX newsletter that has been struggling along for years.

When he knocked us, we figured that he saw *POP'COMM* as a genuine threat to his own operation. Obviously we had rung the bell. We celebrated by giving his newsletter a nice plug in our pages!

Based upon reader suggestions, the magazine has evolved somewhat from the first couple of issues. There have been some columnist changes, including one by popular outcry from the readership. Another columnist left after only one or two issues because I came to feel that he didn't really have much to say. Yet another columnist quit because I didn't agree that he should have the right to ramble on about numerous topics that had little or no connection with the topic of his column. A few columnists were removed because they simply couldn't meet our copy deadlines, despite all efforts to encourage them to do so. Harry Helms, who wrote the *Communications Confidential* column for many months, left because his heavy work schedule just didn't leave him with enough time to devote to the column. Luckily, Helms still finds the time to do occasional feature stories for *POP'COMM*.

The magazine's current crop of columnists is, I feel, excellent. Gerry Dexter and Gordon West have been with the magazine right from our earliest issues. Don Schimmel, who also writes a "ute" column for Bob Grove's *Monitoring Times*, has become a reader favorite. And so on down the line with Macassey, Slattery, Manucy, Brannigan, Dickerson, Noll, and Teach. This is as fine and dedicated a group of professionals as has ever been assembled on a magazine masthead.

Our relationship with SWL clubs is generally good, although I'd have to say that SWL clubs still maintain their traditional overall indifference or mild irritability towards national electronics hobby publications. I've never really understood why this is so, but I do know that it goes back to even the earliest days of the old *Popular Electronics*, *Electronics Illustrated*, and *Communications World*. Readers have written to tell me that some SWL clubs have declining membership rolls and blame it on the increasing popularity of *POP'COMM*.

My own reaction to this is that it's an easy cop-out. The fortunes of most SWL clubs seem to rise and fall with DX propagation conditions. With those conditions now on the increase again, the membership rolls of SWL clubs will probably look a lot healthier than they have during the past couple of years. Clubs should also take into account that some of their ilk are losing members because the groups themselves have become less than fully appealing. Certainly, every SWL club isn't in a state of decline, several

look to be growing and extremely healthy. On the other hand, a few clubs have become rather negative and bitter, embroiled in constant put-downs and hassles, and are comprised of isolated political cliques—it's no wonder that the only members they can keep are the few who can tolerate that scene. One that immediately comes to mind is a group that at one time was attracting more than 200 new applicants each month. Last time I saw their newsletter they were averaging less than 25 per month—and that was before *POP'COMM* was in business!

Our incoming mailbag, it should be noted, is always filled to overflowing. For the most part, the letters from readers are very enthusiastic. Nevertheless, scarcely an issue goes by that doesn't bring in several letters from readers we have managed to disappoint or outrage for one reason or another.

Some readers write to express the hope that we will consider adding various new areas of regular coverage to the magazine, sometimes at the expense of existing areas of coverage. We'd love to accommodate everybody, but we'd end up with a magazine more than 300 pages in length each month that covered computers, stereo, record reviews, and maybe even the rise and fall of Roman Empire, in addition to everything we already cover! And, there are also letters from readers who thoughtfully outline their own ethical, political, social, religious, or other personal standards in the sincere hope that *POP'COMM* can be somehow restructured (and therefore "improved") along those lines.

Then there are those who write to threaten that if we don't discontinue future coverage of some topic they don't like, or stop running *this* or *that* type of cover photo, they'll stop reading *POP'COMM*. Lastly, the mailbag has regular contributors who are duty bound to offer corrections and modifications to statements made in our pages.

Everything is read. In all of the years I've been connected with publications directed at communications users, I don't believe that I have ever come across as widely varied and communicative group of readers—nor as well informed. Even the outraged letters are usually great!

Best of all, the majority of letters that arrive (even the complaints) have been chatty, personal, and very often sprinkled with genuine wit. Perhaps only one letter in several hundred could be considered nasty, really hostile, or worse.

We look forward to the mail, just as we look forward to our sixth year of publication—with enthusiasm. Our hope is that *POP'COMM* is as enjoyable to read as it is to produce each month.

PC

Uniden

70 XLT Pocket Size 20 Channel Programmable Scanner



The 70XLT sets a new standard for portable Scanners in performance, dependability and size. This hard working unit has 20 programmable channels and 10 bands of coverage. It has the most desirable features including Priority, Lockout and Delay. It also includes automatic and manual Search to find new active frequencies. Built-in rechargeable batteries give hours of trouble-free use and quickly charge overnight. A Charger/Adaptor allows the unit to run on 120 VAC and the LCD display includes selectable illumination for night time scanning. The superior engineering of will treat your ears to real life excitement and drama as you've never heard it before.

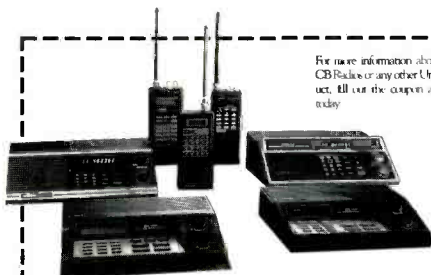

For more information about Uniden CB Radios or any other Uniden product, fill out the coupon and mail it today.

Uniden Corp. of America
Consumer Products Division
6345 Castleton Ct.
Indianapolis, IN 46250

Name _____
Address _____
City _____ State _____ Zip _____
 Scanners CB Radios
 Home Satellite Receivers Radio Detectors
 Telephones Marine Electronics

The Choice of Professional
Golfers Jack Nicklaus
Winner of 20 Major Championships
© 1987 Uniden Corporation of America



uniden[®]
A New Generation of Communications

MAILBAG LETTERS TO THE EDITOR

CB Or Not CB?

I've been a *POP'COMM* reader for three years. The only fault I can find with the magazine is that you seem to be giving the cold shoulder to all of your many CB radio fans. I belong to a Neighborhood Watch program that uses CB for communications. Most of the members of our team read *POP'COMM*, and frequently mention that you should work some 27 MHz coverage into your format. We can't be the only people who feel this way.

Elizabeth Coulson
Dothan, AL

Your aren't! A sufficient amount of mail has come in to make it abundantly apparent that we need regular coverage of 27 MHz communications. We are starting a column called "CB Scene" in this issue. If the column receives reader support in the form of letters, photos, and general enthusiastic input then it will stay in our pages each month. After a long period of dormancy, CB seems to be making a very healthy comeback — but this time around it looks as though it's on the right track as a sane and useful communications tool. We hope to help keep it that way.

— Editor

April Showers

POP'COMM's April issue editorial about the cash value of slices of our hobby spectrum would get a Pulitzer Prize if I were handing them out. I mailed a copy to our local radio club, and another to a hobby newcomer. Since the FCC is complaining about an ever-larger work load, seems like things would be a lot easier for them and everybody else if they simply went to two licenses, General and Novice, and handed out the callsigns like they did before things got so complicated! Someone insulted Alice Brannigan? How could it be? Alice is the one you wished you married instead of the one you did!

Ed Jones, Jr., WB2DVL
Somerset, NJ

The April *Popular Communications* editorial on the rape of the spectrum by greedy corporate sharks was *must reading* for everyone in the field. I suspect that most editors receive *POP'COMM*, but I've sent copies around just to make doubly sure they noticed these comments. Ham radio has one critical ace in the hole—the ITU. Unless the present FCC decides to abrogate our treaty commitments, they simply cannot assign worldwide Amateur frequencies to commercial use, no matter how big the bucks. In developing nations where the spectrum crunch isn't critical, Amateur allocations have vast support. The FCC would have a lot of heavy answering to do to the

ITU if they did what we all suspect they'd really like to do. The wolf is already at the door of the 220 MHz band, however, and the problem is not only real, it is getting worse. By the way, did anybody ever figure out what frequency Kenneth was really on?

Dave Beauvais, KB1F
Amherst, MA

Your April comments regarding threats to the hobby radio spectrum jolted me. It was like something out of a Kafka or Orwell story. The main difference is that they're fiction and you were reporting something that's actually taking place. I read several communications publications, yet none has sized up the situation and spoken about it as bluntly as *Popular Communications*. (Why?) Please don't ever permit your publication to become a complacent and passive observer of what's going on in the world of communications.

Martin Cohen
Los Angeles, CA

Whatever frequency Kenneth was on, he'd better watch it before it's taken over and sold down the river!— Editor.

Taking Issue With Us

I discovered *POP'COMM* just after I was given a scanner for my birthday in July. Now I'm kicking myself for what I've missed in previous issues. My ambition is to build a complete file of all back issues. I'm enclosing my order for the January through June issues of 1987; I hope to obtain them in lots of one year each.

Fred Esterhaus
Lakeland, FL

Filling out a complete file of issues isn't as easy as you think, although many readers tell us that they're trying. Some back issues are completely sold out, several others are getting low in our inventory. The issues for August of '83, February of '86, and even the recent May of '87 are true collectors' items. Since we can no longer supply those issues, they can be obtained from other collectors — and most collectors appear less than anxious to break up their own sets. For now, other back numbers (starting with the issue of September of '82) are still available from us at \$2.50 each, postpaid.— Editor

The Day The Scanning Stopped

I purchased a major brand scanner in June of 1979. It stopped working in September of 1986. The manufacturer worked on it three times and finally wrote to say that they regretted to inform me that the chip needed to repair the unit was no longer available. It's hard to perceive that a major company is at a loss to obtain components

for a scanner that is only eight years old. The company did offer to send me a new scanner (different model) at a 50% discount plus my old scanner as a trade-in. Is this offer a reasonable one? By the way, I enjoyed the "Big Snoop's Guide to Electronic Eavesdropping" in the June issue.

Edward J. Ostrenga
Pawtucket, RI

While it's easy to become emotionally attached to a piece of electronics gear that has provided you with many years of enjoyment, you do have to accept the fact that older models do sometimes reach the point of no repair. While eight years may seem like a short time to you, in terms of the electronics industry it can very easily be eons when it comes to obtaining a component that was specially designed for a specific device. Once that device goes out of active production, so do any custom made components the set required. Any extra components in inventory are used for repair purposes, but when those are used up, that's "it" for any future repairs needing those parts. Scanner technology has greatly advanced in eight years and you can't complain that you didn't get your money's worth out of your recently deceased old friend. The manufacturer's offer is most generous. Since your present scanner can't be repaired, it is totally worthless. If you can use it to cut the price of a new scanner by better than \$130, jump at the opportunity!— Editor

Phone Etiquette

When a utility station is spelling words in phonetics (Alpha, Bravo, Charlie, Delta, etc., etc.), what language is that considered to be? My assumption is that it is English.

Sandor Meszaros
Willow Grove, PA

Technically, if all you copied in a particular transmission were a series of such phonetics, there'd be no way to classify the operator's nationality or language. This is because these are international phonetics and therefore intended for use in all areas of the world as an attempt to transcend language barriers when spelling things. On the other hand, the use of alternate phonetics such as Ashcan, Boxcar, Car, Donkey — or Adios, Boca, Cabeza, Domingo, could be identified specifically as English or Spanish phonetics. If what you heard consisted, for instance, of German conversation that included spelled words or coded groups in standard international phonetics, you'd consider it a German language station using international phonetics. In other words, international phonetics cannot be identified as belonging to any one specific language, even though some monitors incorrectly consider them to be English.— Editor **PC**

NEW! CB Radios & Scanners

Communications Electronics,[™] the world's largest distributor of radio scanners, introduces new models of CB & marine radios and scanners.

NEW! Regency[®] TS2-RA

Allow 30-90 days for delivery after receipt of order due to the high demand for this product.

List price \$499.95/CE price \$339.95
12-Band, 75 Channel • Crystalless • AC/DC
Frequency range: 29-54, 118-175, 406-512, 806-950 MHz. The Regency TS2 scanner lets you monitor Military, Space Satellites, Government, Railroad, Justice Department, State Department, Fish & Game, Immigration, Marine, Police and Fire Departments, Aeronautical AM band, Paramedics, Amateur Radio, plus thousands of other radio frequencies most scanners can't pick up. The Regency TS2 features new 40 channel per second Turbo Scan[™] so you won't miss any of the action. Model TS1-RA is a 35 channel version of this radio without the 800 MHz. band and costs only \$239.95.

Regency[®] Z60-RA

List price \$299.95/CE price \$148.95/SPECIAL
8-Band, 60 Channel • No-crystal scanner
Bands: 30-50, 88-108, 118-136, 144-174, 440-512 MHz. The Regency Z60 covers all the public service bands plus aircraft and FM music for a total of eight bands. The Z60 also features an alarm clock and priority control as well as AC/DC operation. Order today.

Regency[®] Z45-RA

List price \$259.95/CE price \$139.95/SPECIAL
7-Band, 45 Channel • No-crystal scanner
Bands: 30-50, 118-136, 144-174, 440-512 MHz. The Regency Z45 is very similar to the Z60 model listed above however it does not have the commercial FM broadcast band. The Z45, now at a special price from Communications Electronics.

Regency[®] RH256B-RA

List price \$799.95/CE price \$329.95/SPECIAL
16 Channel • 25 Watt Transceiver • Priority
The Regency RH256B is a sixteen-channel VHF land mobile transceiver designed to cover any frequency between 150 to 162 MHz. Since this radio is synthesized, no expensive crystals are needed to store up to 16 frequencies without battery backup. All radios come with CTCSS tone and scanning capabilities. A monitor and night/day switch is also standard. This transceiver even has a priority function. The RH256 makes an ideal radio for any police or fire department volunteer because of its low cost and high performance. A 60 Watt VHF 150-162 MHz. version called the RH606B-RA is available for \$459.95. A UHF 151 watt, 10 channel version of this radio called the RU150B-RA is also available and covers 450-482 MHz. but the cost is \$439.95.

Bearcat[®] 50XL-RA

List price \$199.95/CE price \$114.95/SPECIAL
10-Band, 10 Channel • Handheld scanner
Bands: 29.7-54, 136-174, 406-512 MHz. The Uniden Bearcat 50XL is an economical, handheld scanner with 10 channels covering ten frequency bands. It features a keyboard lock switch to prevent accidental entry and more. Also order the new double-long life rechargeable battery pack part # BP55 for \$29.95, a plug-in wall charger, part # AD100 for \$14.95, a carrying case part # VC001 for \$14.95 and also order optional cigarette lighter cable part # PS001 for \$14.95.

NEW! Scanner Frequency Listings

The new Fox scanner frequency directories will help you find all the action your scanner can listen to. These new listings include police, fire, ambulances & rescue squads, local government, private police agencies, hospitals, emergency medical channels, news media, forestry radio service, railroads, weather stations, radio common carriers, AT&T mobile telephone, utility companies, general mobile radio service, marine radio service, taxi cab companies, tow truck companies, trucking companies, business repeaters, business radio (simplex) federal government, funeral directors, veterinarians, buses, aircraft, space satellites, amateur radio, broadcasters and more. Fox frequency listings feature call letter cross reference as well as alphabetical listing by licensee name, police codes and signals. All Fox directories are \$14.95 each plus \$3.00 shipping. State of Alaska-RL019-1; Baltimore, MD/Washington, DC-RL024-1; Chicago, IL-RL014-1; Cleveland, OH-RL017-1; Columbus, OH-RL003-2; Dallas/Ft. Worth, TX-RL013-1; Denver/Colorado Springs, CO-RL027-1; Detroit, MI/ Windsor, ON-RL008-2; Fort Wayne, IN / Lima, OH-RL001-1; Houston, TX-RL023-1; Indianapolis, IN-RL022-1; Kansas City, MO/ KS-RL011-2; Los Angeles, CA-RL016-1; Louisville/Lexington, KY-RL007-1; Milwaukee, WI/Waukegan, IL-RL021-1; Minneapolis/St. Paul, MN-RL010-2; Nevada/E. Central CA-RL028-1; Oklahoma City/Lawton, OK-RL005-2; Pittsburgh, PA/Wheeling, WV-RL029-1; Rochester/Syracuse, NY-RL020-1; Tampa/St. Petersburg, FL-RL004-2; Toledo, OH-RL002-3. A regional directory which covers police, fire ambulance & rescue squads, local government, forestry, marine radio, mobile phone, aircraft and NOAA weather is available for \$19.95 each. RD001-1 covers AL, AR, FL, GA, LA, MS, NC, PR, SC, TN & VI. For an area not shown above call Fox at 800-543-7892 or in Ohio 800-621-2513.

Regency[®] Informant[™] Scanners

Frequency coverage: 35-54, 136-174 406-512 MHz. The new Regency Informant scanners cover virtually all the standard police, fire, emergency and weather frequencies. These special scanners are preprogrammed by state in the units memory. Just pick a state and a category. The Informant does the rest. All Informant radios have a feature called Turbo Scan[™] to scan up to 40 channels per second. The INF1-RA is ideal for truckers and is only \$249.95. The new INF2-RA is a deluxe model and has ham radio, a weather alert and other exciting features built in for only \$324.95. For base station use, the INF5-RA is only \$199.95 and for those who can afford the best, the INF3-RA at \$249.95, is a state-of-the-art, receiver that spells out what service you're listening to such as Military, Airphone, Paging, State Police, Coast Guard or Press.

Regency[®] HX1500-RA

List price \$369.95/CE price \$218.95
11-Band, 55 Channel • Handheld/Portable
Search • Lockout • Priority • Bank Select
Sidelit liquid crystal display • EAROM Memory
Direct Channel Access Feature • Scan delay
Bands: 29-54, 118-136, 144-174, 406-420, 440-512 MHz. The new handheld Regency HX1500 scanner is fully keyboard programmable for the ultimate in versatility. You can scan up to 55 channels at the same time including the AM aircraft band. The LCD display is even sidelit for night use. Includes belt clip, flexible antenna and earphone. Operates on 8 1.2 Volt rechargeable Ni-cad batteries (not included). Be sure to order batteries and battery charger from the accessory list in this ad.

Bearcat[®] 100XL-RA

List price \$349.95/CE price \$178.95/SPECIAL
9-Band, 16 Channel • Priority • Scan Delay
Search • Limit • Hold • Lockout • AC/DC
Frequency range: 30-50, 118-174, 406-512 MHz. Included in our low CE price is a sturdy carrying case, earphone, battery charger/AC adapter, six AA Ni-cad batteries and flexible antenna. Order your scanner now.

★★★ Uniden CB Radios ★★★

The Uniden line of Citizens Band Radio transceivers is styled to compliment other mobile audio equipment. Uniden CB radios are so reliable that they have a two year limited warranty. From the feature packed PRO 540e to the 310e handheld, there is no better Citizens Band radio of the market today.

PRO310E-RA Uniden 40 Ch. Portable/Mobile CB... \$85.95
NINJA-RA PRO310E with rechargeable battery pack \$99.95
B-10-RA 1.2V AA Ni-cad batt. for Ninja (set of 10)... \$20.95
PRO520E-RA Uniden 40 channel CB Mobile... \$59.95
PRO540E-RA Uniden 40 channel CB Mobile... \$119.95
PRO710E-RA Uniden 40 channel CB Base... \$119.95
PC22-RA Uniden remote mount CB Mobile... \$99.95
PC55-RA Uniden mobile mount CB transceiver... \$59.95

★★★ Uniden Marine Radios ★★★

Now the finest marine electronics are available through CEI. The Unimetrics SH66-RA has 50 transmit and 60 receive frequencies with 25 or 1 watt power output. Only \$169.95. The Unimetrics SH88-RA is a deluxe full function marine radiotelephone featuring 55 transmit and 90 receive channels and scanning capability for only \$259.95. The Unimetrics SH3000-RA is an excellent digital depth sounder, good for 300 feet. It has an LCD continuously backlit with red light display and a 5 ft. or 10 ft. alarm. Only \$189.95. Order today.

Bearcat[®] 800XL-RA

List price \$499.95/CE price \$289.95/SPECIAL
12-Band, 40 Channel • No-crystal scanner
Priority control • Search/Scan • AC/DC
Bands: 29-54, 118-174, 406-512, 806-912 MHz. The Uniden 800XL T receives 40 channels in two banks. Scans 15 channels per second. Size 9 1/4" x 4 1/2" x 12 1/2"

OTHER RADIOS AND ACCESSORIES

Panasonic RF-2600-RA Shortwave receiver... \$179.95
RD55-RA Uniden Visor mount Radar Detector... \$98.95
RD9-RA Uniden "Passport" size Radar Detector... \$169.95
NEW! BC70XL-RA Bearcat 20 channel scanner... \$68.95
BC 140-RA Bearcat 10 channel scanner... \$92.95
BC 145XL-RA Bearcat 16 channel scanner... \$98.95
BC 175XL-RA Bearcat 16 channel scanner... \$156.95
BC 210XL-RA Bearcat 40 channel scanner... \$196.95
BC-WA-RA Bearcat Weather Alert... \$35.95
R1080-RA Regency 30 channel scanner... \$118.95
R1090-RA Regency 45 channel scanner... \$148.95
UC102-RA Regency VHF 2 ch. 1 Watt transceiver... \$117.95
P1412-RA Regency 12 amp. reg. power supply... \$189.95
MA549-RA Drop-in charger for HX1200 & HX1500... \$84.95
MA518-RA Wall charger for HX1500 scanner... \$14.95
MA553-RA Carrying case for HX1500 scanner... \$19.95
MA257-RA Cigarette lighter cord for HX12/1500... \$19.95
MA917-RA Ni-Cad battery pack for HX1000/1200... \$34.95
SMMX7000-RA Svc. man. for MX7000 & MX5000... \$19.95
B-4-RA 1.2 V AAA Ni-Cad batteries (set of four)... \$9.95
B-8-RA 1.2 V AA Ni-Cad batteries (set of eight)... \$17.95
FB-E-RA Frequency Directory for Eastern U.S.A... \$14.95
FB-W-RA Frequency Directory for Western U.S.A... \$14.95
ASD-RA Air Scan Directory... \$14.95
SRF-RA Survival Radio Frequency Directory... \$14.95
TSG-RA "Top Secret" Registry of U.S. Govt. Freq... \$14.95
TIC-RA Techniques for intercepting Comm... \$14.95
RRF-RA Railroad frequency directory... \$14.95
EEC-RA Embassy & Espionage Communications... \$14.95
CIE-RA Covert Intelligence, Elect. Eavesdropping... \$14.95
MFF-RA Midwest Federal Frequency directory... \$14.95
A60-RA Magnet mount mobile scanner antenna... \$35.95
A70-RA Base station scanner antenna... \$35.95
MA548-RA Mirror mount informant antenna... \$39.95
USAMM-RA Mag mount VHF ant. w/ 12' cable... \$39.95
USAK-RA 3/4" hole mount VHF ant. w/ 17' cable... \$35.95
Add \$3.00 shipping for all accessories ordered at the same time.
Add \$12.00 shipping per shortwave receiver.
Add \$7.00 shipping per radio and \$3.00 per antenna.

BUY WITH CONFIDENCE

To get the fastest delivery from CE of any scanner, send or phone your order directly to our Scanner Distribution Center. Michigan residents please add 4% sales tax or supply your tax I.D. number. Written purchase orders are accepted from approved government agencies and most well rated firms at a 10% surcharge for net 10 billing. All sales are subject to availability, acceptance and verification. All sales on accessories are final. Prices, terms and specifications are subject to change without notice. All prices are in U.S. dollars. Out of stock items will be placed on backorder automatically unless CE is instructed differently. A \$5.00 additional handling fee will be charged for all orders with a merchandise total under \$50.00. Shipments are F.O.B. Ann Arbor, Michigan. No COD's. Most products that we sell have a manufacturer's warranty. Free copies of warranties on these products are available prior to purchase by writing to CE. Non-certified checks require bank clearance. Not responsible for typographical errors.

Mail orders to: Communications Electronics, Box 1045, Ann Arbor, Michigan 48106 U.S.A. Add \$7.00 per scanner for R.P.S./U.P.S. ground shipping and handling in the continental U.S.A. For Canada, Puerto Rico, Hawaii, Alaska, or APO/FPO delivery, shipping charges are three times continental U.S. rates. If you have a Discover, Visa or Master Card, you may call and place a credit card order. Order toll-free in the U.S. Dial 800-USA-SCAN. In Canada, order toll-free by calling 800-221-3475. FTCC Telex anytime, dial 825333. If you are outside the U.S. or in Michigan dial 313-973-8888. Order today.

Scanner Distribution Center[™] and CE logos are trademarks of Communications Electronics Inc.

1 Bearcat is a registered trademark of Uniden Corporation.
1 Regency and Turbo Scan are registered trademarks of Regency Electronics Inc. AD #080187-RA
Copyright © 1987 Communications Electronics Inc.

For credit card orders call
1-800-USA-SCAN

**COMMUNICATIONS
ELECTRONICS INC.**

Consumer Products Division

P.O. Box 1045 □ Ann Arbor, Michigan 48106-1045 U.S.A.
Call 800-USA-SCAN or outside U.S.A. 313-973-8888



OFFICIAL NEWS COLUMN OF THE SCANNER ASSOCIATION OF NORTH AMERICA

War Over FCC Rule Making 5836 Heats Up

Last month we published SCAN's comments on FCC RM 5836, a proposal to require labeling of scanner radios to warn users about the Electronic Communications Privacy Act. We supported that proposal as the only practical way to deal with the Privacy Act and also suggested that the labeling requirements be extended to cellular phones so that phone users would know that ordinary open communications is not private.

Since then reply comments have been submitted by the Association of North American Radio Clubs (ANARC) and the Cellular Telephone Industry Association (CTIA). It is clear that the battle is not really over the labeling requirement, or whether the warning label is adequate enough, but over the right to manufacture and sell equipment. One of the most amazing comments was the one filed by CTIA in regard to labeling. They stated that, "Any such label would, if done in an honest and good faith manner, require a primer on the Privacy Act and in the end, probably only a student of the law would be able to understand it." Unquote. What an indictment of the Privacy Act! CTIA says that it can't be understood by the average citizen! As we said when the Privacy Act was being debated, unenforceable laws (and that includes laws the average citizen cannot understand) is poor public policy. Just ask any judge or law enforcement official.

What is CTIA's solution to the problem? Ban equipment, of course. Never mind that the Privacy Act referred to equipment primarily designed to intercept cellular phone frequencies. Now, CTIA in its comments says that, "the manufacture and sale of scanners capable of intercepting cellular telephone communications are patently illegal under the Privacy Act." Yes, the "other shoe" we predicted has fallen. First, the proponents of the Privacy Act said they only wanted to stop the sale of equipment with the primary purpose of monitoring cellular. In fact, they alluded to the potential millions of \$9.95 imported cellular-only receivers as their real concern. Now that the law has passed they want to ban full coverage scanners. The traditional American right to free access of the airwaves is about to take another blow from interests that are purely commercial. CTIA is attempting to take away a right to own radio receivers that Americans have enjoyed, in unrestricted fashion, since the beginnings of radio. And, as ANARC points out in their reply comments, "The problem of cellular's utter openness to unauthorized interception cannot be solved by a rulemaking limited to scanners, regardless of the decision reached."

That has been the basic problem of cellular from the beginning. The open, ordinary FM transmissions used and the omnidirectional character of their transmissions has them trapped in a house of glass. After all, we're not talking about wire tapping or intercepting point-to-point microwave. A tuneable UHF TV receiver . . . a block converter hooked up to an FM broadcast receiver . . . cellular is very easily intercepted by these and other means. But rather than face up to the reality with user notification, or a technological "fix" such as encryption, the industry has chosen to try to legislate reality. It can't work. But in the meantime they are trampling on some very fundamental rights of U.S. citizens.

To demonstrate just how far some of the proponents of restricting radio receivers would go, you should know the reply we received to our challenge about frequency converters. These converters, sometimes called "block converters," can make a receiver with coverage of 450-470 MHz useful at, say, 870-890 MHz. There is no way to tell exactly what frequencies this converter is intended to be used for; it depends upon what frequency the basic receiver is used on. The reply we received to this revelation was a question, "Well, is it possible to make the converter inoperative on cellular frequencies?" My answer was, "Well, I suppose it is tech-

nically feasible to build a trap filter or use a bandpass filter to exclude some frequencies, but that would cost many times the cost of the converter itself to offer any real degree of protection." The response: "Cost isn't the issue here. If it can be technically achieved it should be done or those devices should be banned, too." So there you have it. At all costs to radio hobbyists, other users of the radio spectrum, not to mention a basic right of all citizens to own receivers, some people in the cellular industry want to promote a myth that cellular phones are private. There are others in the cellular phone industry who know better, but have felt until now that they could not step forward to let their true opinions be public. Before this gets out of hand, I think that the time to do so is now.

Where is Amateur Radio Leadership On This Issue?

As this is written, not a single comment has been filed on RM 5836 by the Amateur Radio community. This is similar to what happened on the Privacy Act, where the "Ham" community entered the battle very late in the game. Personally, I can't understand why. Perhaps it is preoccupation with the current battle to save the 220 MHz allocation . . . but it seems to me that the issues with RM 5836 are so fundamental that they would rank just as importantly with the leadership in Amateur Radio. Apparently not, which may be to their sorrow in the years ahead.

**“. . . people in the cellular industry
want to promote a myth
that cellular phones are private.”**

SCAN does not speak as an outsider on this issue. Over 20% of our membership have Amateur Radio licenses. Speaking for myself, I have been an active Ham operator for over 30 years, so I relate acutely to the frustrations of those Ham members who can't understand why we are not getting support to fight these issues. There is a feeling among some that the license will be the "special exemption" that will eliminate any impact of this legislation and subsequent rulemaking. Don't bet on it. We may find ourselves locked in with rulings that preclude the practical manufacture of frequency converters, for instance. Already much of the communications outside the Ham bands that many of us listen to has been technically declared "illegal." No direct impact on Amateur Radio? I guess it depends upon your interpretation.

Personal Radio Service Claims Victory

As clear evidence that it does not take huge numbers of people or large bank accounts to influence things at the FCC, the users of the GMRS (formerly Class "A" CB) have succeeded in defeating a proposal to establish a new Consumer Radio Service. According to Corwin Moore of the Personal Radio Steering Group, "The Consumer Radio Service was an internal FCC proposal, a service which nobody asked for, and clearly nobody wanted."

GMRS is the only UHF private radio service in which individual citizens can use radio for both commercial and non-commercial family communications. It has been a service that has been "under fire" for years, first with a reduction in channel assignments and later with encroachment by regular commercial two-way radio users. Through it all, however, GMRS has been growing. Many GMRS community repeater systems are in operation around the country. If you would like more information you may write to the Personal Radio Steering Group, P.O. Box 2851, Ann Arbor, MI 48106.

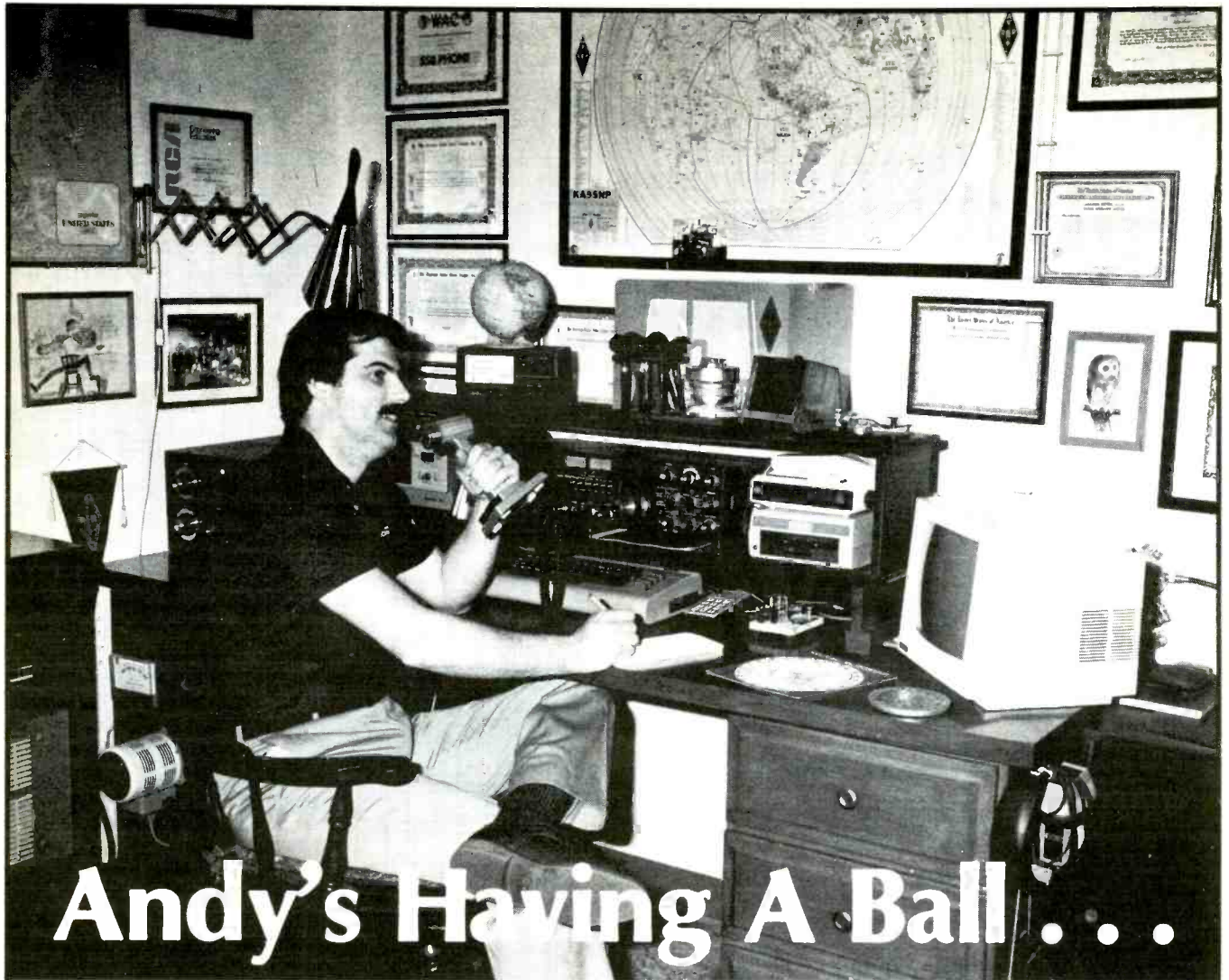

Andy's Having A Ball . . .

and you can too!

Andy is a Ham Radio operator and he's having the time of his life talking to new and old friends in this country and around the world.

You can do it too! Join Andy as he communicates with the world. Enjoy the many unique and exclusive amateur bands . . . the millions of frequencies that Hams are allowed to use. Choose the frequency and time of day that are just right to talk to anywhere you wish. Only Amateur Radio operators get this kind of freedom of choice. And if it's friends you're looking to meet and talk

with, Amateur Radio is the hobby for you. The world is waiting for you.

If you'd like to be part of the fun . . . if you'd like to feel the excitement . . . we can help you. We've got all the information you'll need to get your Ham license. Let us help you join more than a million other Hams around the world and here at home. Who are we? We're the American Radio Relay League, a non-profit representative organization of Amateur Radio operators.

For information on becoming a Ham operator
circle number 110 on the reader service card or write to:

AMERICAN RADIO RELAY LEAGUE Dept CQ, 225 Main Street
Newington, Conn. 06111.

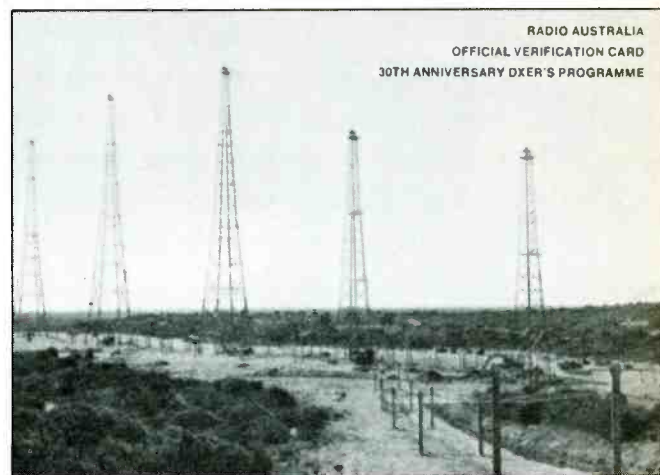
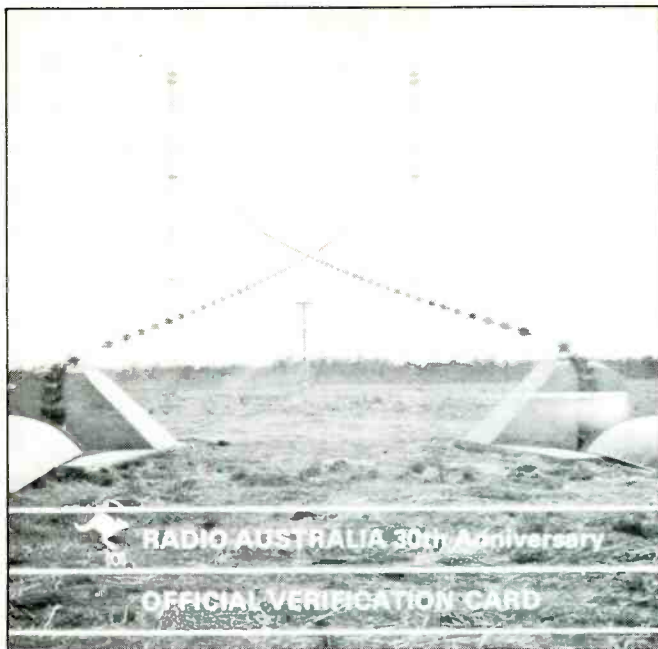

Station Profile

Radio Australia

Darwin & Carnarvon

BY DR. ADRIAN M. PETERSON

Back on that fateful Christmas Eve in 1974, I tuned my receiver to the familiar Radio Australia channel 17,870 kHz and was amazed to hear that Darwin city had been devastated by a cyclone. At the time, I was living in Colombo, Sri Lanka, and, in order to keep up with the news, I relayed the shortwave programming from Australia around my home via a wireless microphone.

The news was devastating. A cyclone had ripped through the city and suburban areas of Australia's northern capital, destroying 80% of the buildings, sinking ships in the sheltered harbor, as well as cutting off water, electricity and phone services. The local radio and TV stations were off the air, and the Radio Australia relay station was disabled. Fortunately, few people were killed in this horrendous event.

In a heroic attempt to provide a communication service for the stunned survivors, emergency programming was produced in the studios of 8DR, the government-owned AM radio station in Darwin. However, the link to the transmitter base was cut, and in any case, the antenna had been levelled. Programming was therefore routed 2,000 miles via cable to Melbourne on the south coast, where it was again rerouted to the Radio Australia shortwave base at Shepparton, central Victoria. The shortwave programs were received off air at an emergency

AM transmitter station inland from Darwin, and rebroadcast live to the inhabitants of the devastated city. The radio signals travelled more than 4,000 miles in a circuitous route to bridge the short gap between the studios in Darwin and the nearby emergency transmitter base.

The emergency transmissions from 8DR via Radio Australia Shepparton provided a constant radio service for the city of Darwin in the aftermath of the cyclone. In addition, as the city began to recover from its deadly wound, the world could listen in, as I did. This remarkable, and at times tenuous radio link was in operation for several weeks until the normal AM radio service in Darwin was restored.

The Radio Australia relay facilities are located on Cox's Peninsula, just twelve miles across the harbor from Darwin. An unsurfaced and dusty highway, 100 miles around the peninsula, is the only road link between the city and the big radio station.

The Radio Australia transmitter base on Cox's Peninsula contains a bevy of three computer-controlled Collins transmitters, each rated at 250 kW. The antenna farm, at the time of the cyclone, consisted of five log periodic arrays, vertically polarized, and capable of accepting the combined output of any two transmitters. These were beamed towards three main areas of Asia. Test

broadcasts from the Darwin relay station were commenced in December 1968, and regular full-time operation was begun on September 5, 1971. The station was on the air in full usage for only three years before it was disabled by Cyclone Tracy.

The receiver base, eight miles distant, received programming off air and by land line from the Radio Australia studios in Melbourne. The landline was looped via the city studios of 8DR so that ABC personnel in Darwin city could insert local programming if necessary. Three utility transmitters are also located here, and these are used for out-back communications. One of these, VJY, was used for a couple of years for the relay on shortwave of ABC news to the scattered settlements in the territory. The total area of the two installations is twelve square miles.

The Darwin transmitter base, known officially as a booster station, was constructed for the purpose of relaying Radio Australia programs in several languages to Asia and the North and West Pacific.

After the cyclone was over, an assessment of the damage indicated that several antennas were felled, the million dollar electricity cable across the floor of the harbor was cut, and salt water seepage had damaged the transmitters. The station would be off the air for some time.

In order to provide transmissions to Asia

VERIFICATION CARD

QSL

Station **VLU2** Location **CARNARVON, ISLAND**
 Frequency **1420 KHz** Wavelength **MW**
 Power **500 W** Date **22-9-77** & **23-9-77**
 Time **0815** (GMT) Your station and mine both
 heard in **CARNARVON** and from **aircraft**
 correct.

STATION **RUBBERBARK**
 BROADCASTING
 STATION
 Australia Post

ST. 6 76

ADRIAN M. PETERSON
 'SALISBURY PARK'
 BOX 13
 POONA 411 001
 INDIA

airmail

Copy of QSL (prepared card) from VLU2 heard from Carnarvon and from airplane.

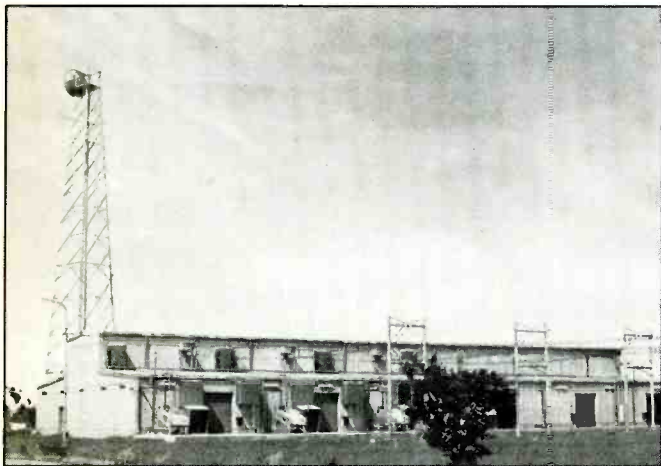

Transmitter base, Radio Australia Darwin.

on an emergency fill-in basis, a search was made for a new site on the western coast of the continent. The first site considered was the OTC (Overseas Tele-Communication) station at Ghangara, on the edge of the state capital, Perth. This station had been erected as a NASA relay link between Mauritius in the Indian Ocean and Moree in New South Wales, and it contained three communication transmitters of 7½ kW each. This station was re-activated for a series of test transmissions on behalf of Radio Australia in February and March 1975. Tapes were produced in the Melbourne studios and played into the transmitters on site. These unique test transmissions, which were verified with regular QSL cards from Radio Australia, demonstrated that the west coast of the continent was suitable as a site for a relay station.

It was important to get a new station on the air as soon as possible, hence another abandoned NASA tracking station, this time near Carnarvon 500 miles to the north, was chosen. The building was refurbished and two transmitters and associated equipment were installed.

Just one year after the relay station near Darwin in the Northern Territory was disabled, the replacement facility at Carnarvon in Western Australia was on the air with a series of test broadcasts. The program link at first was via a 35-kW SSB transmitter at

Lyndhurst and this was replaced soon afterwards by the broadband trans-continental microwave relay, traversing some 2,000 miles across the desert.

The two program lines across the desert were designated VLK for transmitter 1 and VLL for transmitter 2. This is reminiscent of the internationally allocated transmitter call-signs as used in Australia, such as VLR Lyndhurst and VLQ Brisbane.

The first broadcast from Radio Australia Carnarvon was aired on December 20, 1975, using the new 250-kW Gates transmitter, designated as No. 1. The second unit, a 100-kW Harris transmitter, designated as No. 2, was switched into service on February 15, 1976, some two months after the introduction of the larger unit. The 100-kW Harris, transmitter originally intended for the new home service on short-wave in the Northern Territory, was diverted for installation at Carnarvon.

Interestingly, just one week after the commencement of transmissions from the second unit, the station was taken off the air. An approaching cyclone off the Western Australian coast gave the first occasion for the lowering of the antennas. Regular broadcasting from Carnarvon commenced officially on March 7, 1976, with a daily schedule, 2100-1730 UTC.

Subsequently, a 300-kW transmitter

Adrian M. Peterson

This card confirms your reception on
 **14.295** MHz at **0.33.2** G.M.T.
 on **24.9.77** **2.3.1977**

Transmitter Power 10, 50, 100, 250 kilowatts

SHEPPARTON 145° 25' E / 36° 20' S
 LYN DHURST 145° 16' E / 38° 03' S
 DARWIN 130° 38' E / 12° 25' S
 BRISBANE 153° 01' E / 27° 19' S

Perth.

Peter Humphrey

DIRECTOR OF OVERSEAS SERVICES

Radio Australia

P.O. BOX 428G, G.P.O., MELBOURNE, 3000, AUSTRALIA.

Photo: Koala and baby. **2502**

Copy of Radio Australia QSL for 7.5 kW test transmission from Gngarwa, Western Australia.

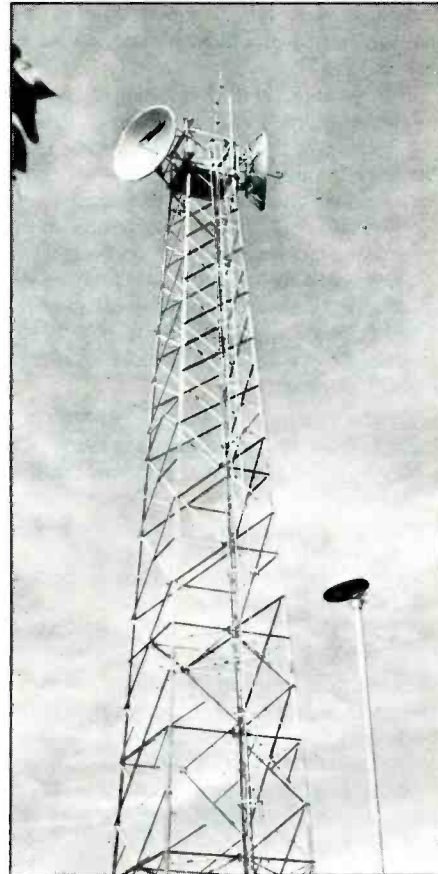

Antennas at Radio Australia Darwin, receiver base.

 TERRITORY OF CHRISTMAS ISLAND

GOVERNMENT OFFICES
 CHRISTMAS ISLAND
 INDIAN OCEAN

QUOTE IN REPLY

26th September, 1977.

Mr. Adrian M. Peterson,
 "Salisbury Park"
 Box 15
 POONA 411 001 India.

Dear Mr. Peterson,

Many thanks for your signed reception report of VLU2. We are pleased to confirm your reception of VLU2 on August 28th at 04:18 G.M.T. This would have to be one of the most unusual reports we have received and I believe, the first from a commercial aircraft.

You requested some historical background concerning VLU2. The station was first operated as a part time project by a resident Telecommunication Engineer Mr. Don Reid in 1965/66. It was officially opened and received its call sign on the 1st September, 1967, and a resident Broadcast Officer was appointed.

In the ensuing 10 years the station has increased its operating hours to almost 100 per week in English, Malay, Mandarin and Cantonese, with occasional announcements in Hokkien, Hindi and Tamil.

We have a full time staff of three, two Broadcast Officers and a Typist/ Receptionist. The remainder of our English broadcasts and all our Asian language programmes are presented by local part time announcers.

The new transmitters of which you spoke in your letter have not yet been installed, but are expected to be operational by Christmas this year, they are S.T.C. Transistorised units in parallel.

Thanking you again for your report.

Yours faithfully,

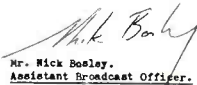
 Mr. Nick Bosley.
 Assistant Broadcast Officer.

Copy of QSL letter from VLU2 Christmas Island, in response to report logged in commercial aircraft.

 TERRITORY OF CHRISTMAS ISLAND

GOVERNMENT OFFICES
 CHRISTMAS ISLAND
 INDIAN OCEAN

QUOTE IN REPLY

8th September, 1977

Mr. Adrian M. Peterson,
 "Salisbury Park"
 Box 15
 POONA 411001 INDIA.

Dear Mr. Peterson,

We are pleased to confirm your reception report of VLU2 on the 23rd of August at 1224 hours. G.M.T.

This would be one of the most accurate DX reports received from such a distance in the last 12 months, and we thank you for the report.

It is interesting to note that during late August this year we experienced very good SW reception from Radio Australia's Carnarvon Transmitters.

Best Regards,

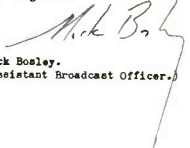
 Nick Bosley.
 (Assistant Broadcast Officer.)

Copy of QSL letter from VLU2 acknowledging reception from Carnarvon, Western Australia.

valued at \$1.75 million was installed at Carnarvon, and was officially inaugurated on May 6, 1984.

Some time after the beginning of all these events, in June 1977, to be exact, I made my first visit to these two radio installations. We, as a family, flew from mainland Southern Asia to Australia, via Indonesia, and spent a few days at the exotic beach on the fabled island of Bali. At the time, there was a once-a-week flight from Bali direct to Darwin, and this took us from the island of active volcanoes, across the limpid blue waters of the Arafura Sea, to Australia's northern capital, Darwin.

By the time we arrived in northern Australia, Darwin had been rebuilt following the cyclone, and it was now a modern bustling city. Housing was new and modern, thoroughfares were wide and fully paved, and trees, gardens and lawns were well established. There was little evidence of the horrendous event three years earlier.

In the coolness of the tropical dawn, my teenage son and I joined the Radio Australia staff at the harborside in Darwin, ready for the quick ride by motor launch across the harbor to the Radio Australia facilities on uninhabited Cox's Peninsula.

At the first installation, we saw the bank of receivers and the communications transmitters used for the relay of Radio Australia programs from Melbourne. One of the communication transmitters was VJY, the ABC news service for outback residents in the Northern Territory. This brief daily program

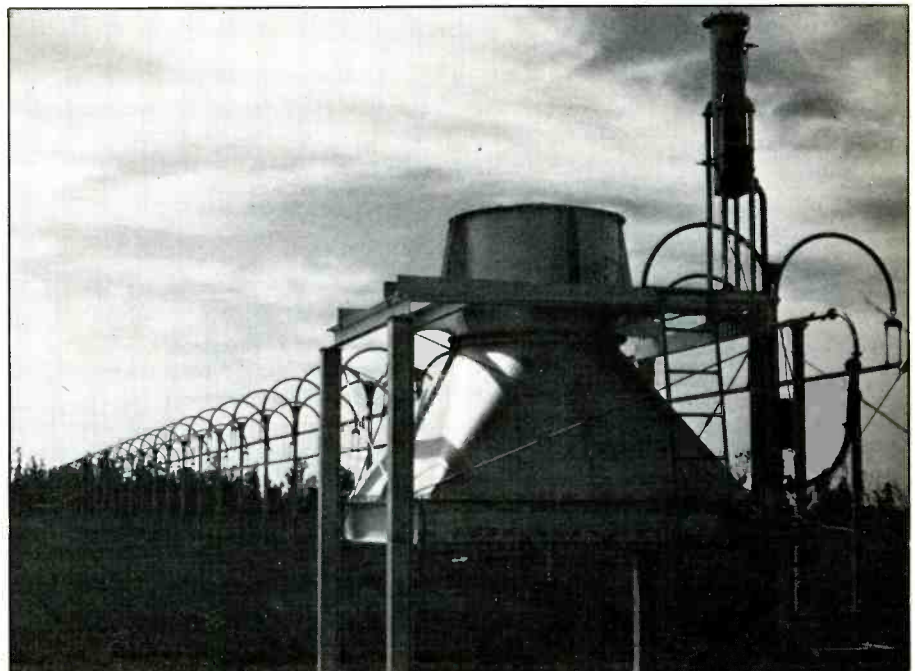

Dummy antenna, stainless steel, Darwin.

was a fill-in service, and it was on the air until the introduction last year of the new home service shortwave stations in the Northern Territory, VL8D, VL8T and VL8K.

Though the city had been rebuilt, some evidence of the devastation caused by the cyclone was still visible out on Cox's Penin-

sula. The eye of the cyclone had passed between the receiver base and the transmitter base; the trees were all stripped, still standing, all dead.

At the time of our visit, the Darwin station was still in stand-by mode. Regular test transmissions were radiated through a large

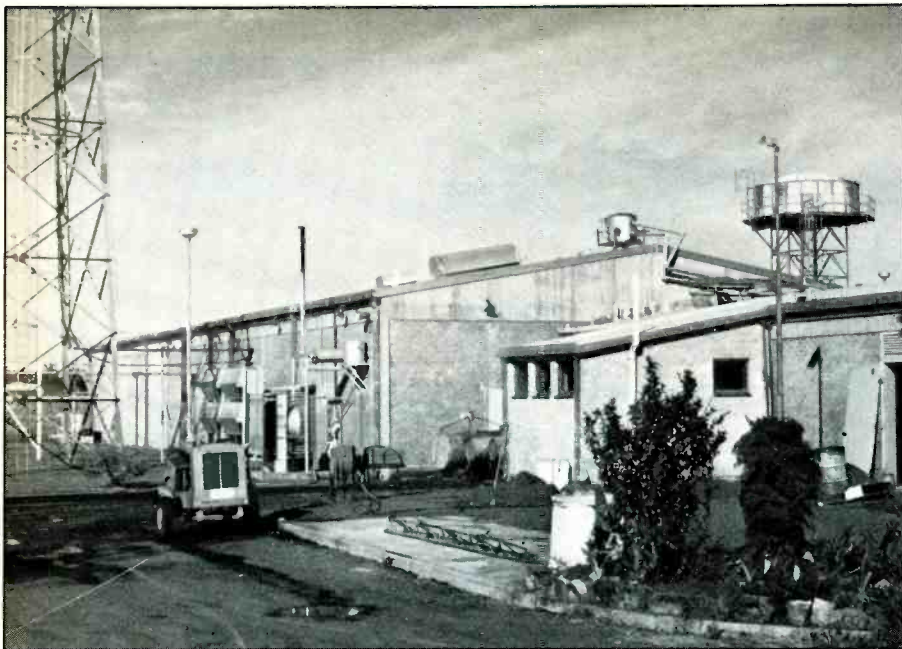

Receiver base, Radio Australia, Darwin.

stainless steel dummy antenna system to keep the equipment in top working condition. The station did not re-enter regular relay service again until just a couple of years ago, upon the re-erection of an antenna system.

A few weeks after our entry into Australia at Darwin we flew out again to Asia, this time via Perth in Western Australia. I took a brief side trip up to Carnarvon to see the new shortwave station. The 500-mile journey by small commuter plane took me across the barren but picturesque desert country that I had traversed years before by car. As the small passenger plane neared Carnarvon, the Radio Australia relay base on low Brown's Range was a vivid site. White and red antenna masts, a neat white building, green Australian shrubs, and the blue Australian sky completed the picture.

A quick trip by taxi from the country airport, past the ABC regional transmitter 6CA and the government satellite station,

brought me to the Radio Australia transmitter base on the edge of Carnarvon. Here I saw the two large shortwave transmitters that I had been monitoring from Asia.

The town of Carnarvon in Western Australia was named after the old city Caernarvon in Wales. Interestingly, the original Caernarvon also featured in radio history. Early wireless transmissions emanated from the Marconi long-wave spark transmitter MVV at Carnarvon in Wales during the era of World War I.

That evening, I stayed in Australia's Carnarvon, in the two-story wooden hotel. I requested a room overlooking the Indian Ocean, with the intention of trying to log the

elusive AM station VLU2 way out across the ocean on Christmas Island. On many occasions, while in Sri Lanka, India, Singapore and Indonesia, I had tried to tune this station, without success. On that eventful evening, I successfully heard, for the first time, the evasive VLU2, which at the time was radiating 500 watts on 1420 kHz.

I returned to Perth, delivered a lecture to a convention of Telecom engineers on the subject of monitoring for Radio Australia, and boarded an international passenger plane bound for Singapore. This plane flew along the Western Australian coastline, and I saw again, Radio Australia Carnarvon from the air.

The plane continued north along the coastline; we came to Exmouth, the site of the large American communication facility. This station communicates with submarines underwater through a VLF transmitter with the appropriate Australian callsign, VLF. Here at one stage, AFRTS (American Forces Radio TV Service) received approval to erect an entertainment station with a U.S. callsign. (Does anybody know what that callsign was?) Instead though, the ABC erected 6XM at Exmouth.

When our plane was way out over the edge of the Indian Ocean, I was invited into the flight deck and given the use of the aircraft radio. Again, I tuned in to VLU2, Christmas Island. Subsequent QSL's confirmed the reception of this exotic station as heard from the two locations, Carnarvon in Western Australia and the plane over the Indian Ocean.

Radio Australia in both Darwin and Carnarvon can be heard quite readily here in North America. (See sidebar for times and frequencies.) The address for the large and colorful QSL cards is: Radio Australia, Box 428G, Melbourne, Victoria 3001, Australia. **PC**

Radio Australia

English

(Latest Available Schedule)

Time/UTC	Freq
0000-0310	17750
0100-0200	15395
0300-0500	15320
0400-0900	17750, 15395
0600-0700	15315, 11945
0700-1030	9655
0900-1000	9710
1100-1200	11705, 9645
1200-1330	7205
1330-1430	7135
1500-2030	7215
2100-0730	15240
2200-0200	15320

BUGGED ???

Find hidden radio transmitters (bugs) in your home, office or car. The TD-17 is designed to locate the most common type of electronic bug—the miniaturized radio transmitter—which can be planted by anyone, almost anywhere.

The TD-17 warns of the presence of nearby RF transmitters, within the frequency range of 1 MHz to 1,000 MHz, when the RF Alert LED turns on. The flashing Range LED and audio tone give an indication of the distance to the bug. The Sensitivity control, used in conjunction with the two LEDs, helps you quickly zero in on hidden bugs.

The hand-held TD-17 weighs less than 7 oz. and is housed in a high-impact plastic case. Furnished complete with battery, antenna, instruction manual and one year Limited Warranty. Save \$100 to \$200 and order at our factory direct price of only \$98. Satisfaction guaranteed or your money back. Catalog \$1 or FREE with order.



CAPRI ELECTRONICS
P.O. Box 589G
Bayfield, CO 81122
(303) 884-9084



POP'COMM Scans:

The Fire Radio Service

High-Intensity Excitement From This Low-Profile Service

BY RICK MASLAU, KNY2GL

Amidst all of the excitement of using scanners to monitor police, federal agents, and many other high-profile communications services, the Fire Radio Service has taken an undeserved back seat. We can't think of any good reason for this except that perhaps it suffers from a lack of publicity. That's where we come in—to help scanner users to get an overview of this communications service that is so vital to the safety of our lives and property.

Fire departments use communications for several purposes, including dispatch, fireground activities, and for mutual aid (liaison with other departments in the area). Although most fire departments in the U.S. operate on special channels set aside by the FCC for their exclusive use, some use channels in the Local Government Radio Service in addition to or instead of exclusive Fire Radio Service channels. Many fire departments operate their own ambu-

lances and rescue squads; many of these units utilize frequencies in the Special Emergency Radio Service.

Larger fire agencies may utilize a myriad of frequencies, each for a different purpose and/or for different districts or zones of a city or county. What with one thing and another, most fire departments seem to end up with a minimum of two channels. Contrast this with New York City, which uses a dozen channels, including special frequencies set aside for handheld transceivers, for fire inspectors, and other special purposes. In fact, most major cities from Miami to Los Angeles, Seattle to Baltimore, employ a wide spectrum of channels.

If you're willing to do a bit of exploring with your scanner, you should be able to zero in on some exciting communications within your own community, and in areas that surround you. When skip reception conditions are optimum, check out Fire Radio Service channels below 50 MHz for stations that you can receive from thousands of miles away! Don't sell this service short for providing high-intensity excitement. It's there if you'll just look for the stations. We've provided some information to help you search out the action.

Fire Service Scanning

Mutual Aid operations between different agencies are often found on: 45.88, 154.265, 154.28 and 154.295 MHz, although such operations can turn up elsewhere, too.

Low power frequencies, usually used for handheld transceivers at fireground sites: 33.42, 46.30, and 153.83 MHz.

Mobile-only frequencies are used primarily for fireground operations and (above 150 MHz) are often used for repeater inputs: 33.46, 33.50, 33.54, 33.58, 33.62, 33.66, 46.22, 46.24, 46.26, 46.28, 153.77, 153.89, 153.95, 154.07 MHz.

General FD base/mobile operations: 33.44, 33.48, 33.52, 33.56, 33.60, 33.64, 33.68 to 33.98 (a channel every 20 kHz), 46.06 to 46.20 (20 kHz channel spacing), 46.36 to 46.50 (20 kHz channel spacing), 154.13 to 154.25 (15 kHz channel spacing), 154.31 to 154.445 (15 kHz channel spacing), 453.05 to 453.95 (50 kHz channel spacing), 460.525, 460.55, 460.575, 460.60 MHz.

UHF "offset" channels used on a shared basis by FD's and other public safety agencies: 453.0375 to 453.9625 (250 kHz channel spacing), 458.0375 to 458.9625 (250 kHz channel spacing), 460.4875, 460.6125, 460.6375, 465.5125, 465.5375, 465.5875, 465.6125, 465.6375 MHz.

UHF-T band channels shared by FD's and other public safety agencies within 50 miles of the metropolitan areas indicated. Stations are restricted by power and antenna height specs to limited signal coverage. Channel spacing is at 25 kHz and paired frequencies are located 3 MHz higher than those frequencies shown below:

Boston, MA: 470.3125 to 471.1375, 482.3125 to 483.1375 MHz.

Chicago, IL: 470.3125 to 471.1375 MHz.

Los Angeles, CA: 470.3125 to 471.1375, 506.3125 to 507.2625 MHz.

New York, NY: 470.3125 to 471.4125, 476.3125 to 477.4125 MHz.

Philadelphia, PA: 500.3125 to 500.4375, 500.5625, 500.6625, 500.6875, 500.7375, 500.7875 to 500.9125, 500.9625, 500.9875, 501.0625, 501.1125, 501.1375 MHz.

San Francisco, CA: 482.3125, 482.3375, 482.3875 to 482.4875, 482.5375, 482.5625, 482.6125, 482.6875 to 482.7625, 482.8125 to 482.9125, 482.9625, 483.0125, 488.3625 to 488.4625, 488.5125, 488.5625, 488.6125 to 488.6875, 488.7375, 477.7625, 488.8375, 488.8625, 488.9125, 489.0125 to 489.0625, 489.1125, 489.1375 MHz.

Washington, D.C.: 488.3125, 494.3125 to 495.4125 MHz.

Although there are exceptions, plus a few oddball frequencies (such as 166.25 and 170.15 MHz, assignable only within 150 miles of New York City, NY), the information given here should help you gain access to the majority of FD communications in your region.

PC

Subscribe Today To The World's Leading Magazine For Shortwave & Scanner Listeners!

- International Broadcasting
- Utility Monitoring
- Scanners
- Shortwave and Longwave
- Satellites
- Electronic Projects
- Listening Tips
- Frequency Lists
- Equipment Reviews
- News-breaking Articles
- Feature Articles
- Exclusive Interviews
- Insights by the Experts
- New Products



Each month **MONITORING TIMES**, the first wide-spectrum listener's publication and still the best, brings you 64 giant tabloid pages of late-breaking information on every aspect of monitoring the radio spectrum.

Fast-paced and information-packed, **MONITORING TIMES** consistently scoops the publishing industry.

ORDER YOUR SUBSCRIPTION TODAY before another issue goes by: only \$15 per year (U.S. and Canada), \$22 per year (foreign) or send \$1 for a sample issue (foreign send 2 IRCs).

MONITORING TIMES

P.O. Box 98

Brasstown, N.C. 28902

CIRCLE 152 ON READER SERVICE CARD

RF Limited

Suggested
Retail Price
\$99.95



- New UV-800
- Converts your UHF scanner to Cellular Telephone Frequencies!
- 384 MHz offset
- 12-13.8 VDC operation
- patch cord included
- 1 year limited warranty
- Send for free brochure
- Dealer inquiries invited

Dimensions - Height: 1"; Width: 2 1/2"; Length: 4 1/4"

P.O. Box 1124 • Issaquah, Washington 98027
Telephone (206) 392-0399
Telex 329 473 BURGESS SEA
Facsimile (206) 392-0419

CIRCLE 160 ON READER SERVICE CARD

September 1987 / POPULAR COMMUNICATIONS / 15

Radio's Rousing Days

Don't Touch That Dial! Stay Tuned For A Report On Radio's Roots.

BY ALICE BRANNIGAN

Of all of the early broadcasting stations, perhaps none was more well known than WLW of Cincinnati. Thanks to information compiled by W5EJ for the Quarter Century Wireless Association (QCWA), we have information that tracks WLW's rich history right back to its beginnings as a front parlor 20-watt Ham station.

The Ham station went on the air 3 March 1921. It was known as 8CR and licensed to Powel Crosley, Jr. Only a year had passed when Crosley moved 8CR to Northside (a Cincinnati suburb) and transferred the license to the Crosley Manufacturing Company, an action that also changed the call-sign to WLW and gave the station a frequency assignment of 832 kHz. It ran 50 watts. An Experimental call-sign of 8XA was also assigned at that time.

In less than a year, WLW had changed frequency to 970 kHz and ran its power up to 500 watts. By January of 1925, WLW was on 710 kHz and pushing out a 5,000-watt signal—the first broadcasting station to run that much power.

With a signal of such strength, WLW could be heard over a wide area. In 1927, the newly-created Federal Radio Commission moved WLW to 700 kHz, a clear channel. Prospering, in late October of 1928, WLW moved to Mason, OH and installed the nation's first 50-kW broadcast transmitter. WLW became a natural choice to see the results of what a half-million watt (500 kW) transmitter would do if turned loose on the broadcast band. The FCC was considering pegging 500 kW as the power limit for Class 1A stations but needed to know about interference and signal coverage for stations using that much power. WLW and KDKA received Experimental licenses for 500 kW in 1934, and such broadcasts continued until March of 1939. Although WLW was hopeful of being permitted to continue super-high power operation, the FCC wouldn't renew its authorization and told WLW to return to 50 kW.

In 1962, the question of broadcasters operating with super-power was again raised. Stations KSL, WGN and WLW (and probably others) actually filed applications with the FCC for such operation. At that time, WLW stated that its old 1930's rig still existed and might be modified to run 750 kW.

The modified WLW transmitter was to use three separate circuits consisting of two type D-1060A tubes each. The filaments of these bottles ran 14.5 volts at 330 amps,



The control console of 500-kW station WLW in 1934, with Chief Transmitter Engineer J.E. Whitehouse doing the honors. This panel also ran Crosley's other stations, WSAI and shortwave relay W8XAL.

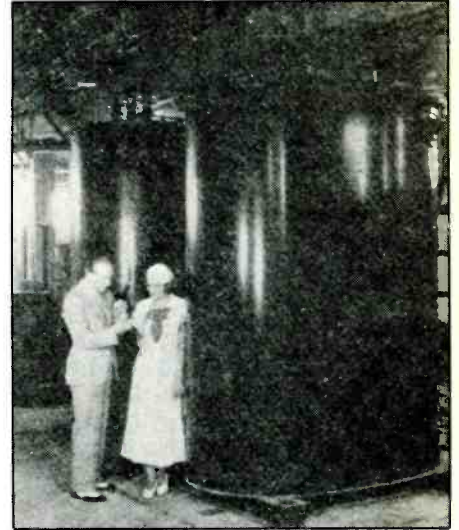

To handle the 500-kW audio, a pair of 50-ton modulation transformers was designed and built for WLW. They required 1,400 gallons of oil!

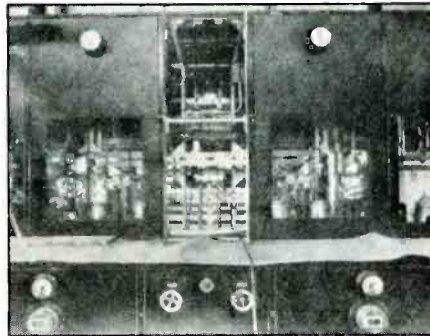

The 1934 WLW half-million watt transmitter, showing one of the three 180-kW RF units. Each had four 100-kW tubes. The entire transmitter panel was 16 feet high by 54 feet in length!

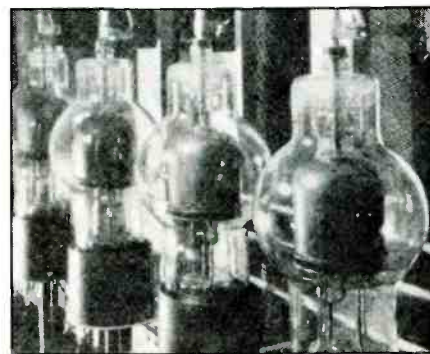

The super-power WLW transmitter required 1,200 amps at 12,000 volts for the plate supply. Six mercury vapor rectifier tubes (rated at 450 amps each) were employed in the 3-phase, full-wave rectifier system.

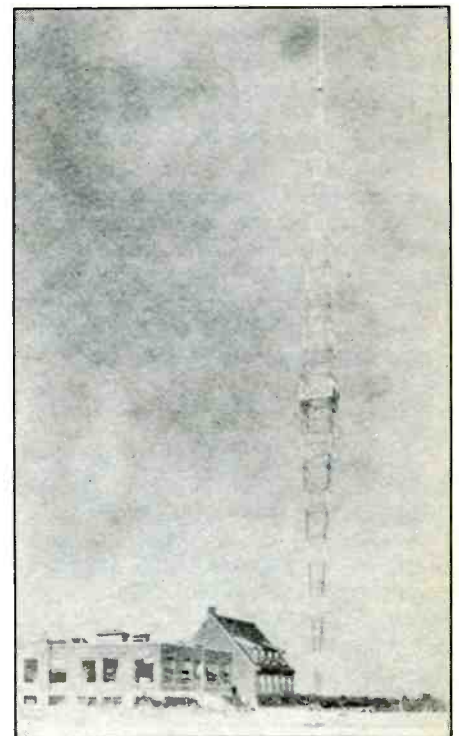

The WLW antenna was mounted on an insulating base that could support a 450-ton load (weight of the 831-foot tower used in 1934, plus the down pull of the insulated guy wires).

with a starting current of 1000 amps. They took 15 seconds to light up! The DC plate voltage was 12,000 volts. Running 750 kW on 700 kHz, the 708-foot high WLW tower would have had an antenna current of almost 45 amperes—a far cry from 20 watts! Nothing came of the proposal, and no positive action was ever taken on the granting authorization for any of these super-power stations. WLW, however, still puts through a very healthy signal with its 50 kW on 700 kHz.

A Mystery Solved

In the May issue we ran a photo sent in by a reader trying to identify a WWII transmitter. To the rescue, David White of Cherryfield, ME.

David identifies the unit as the T-784 component of the GRC-109 radio, intended to be used along with the R-1004 receiver and PP-2625 power supply to make up the GRC-109. David believes that this radio may have been used for intelligence gathering purposes.

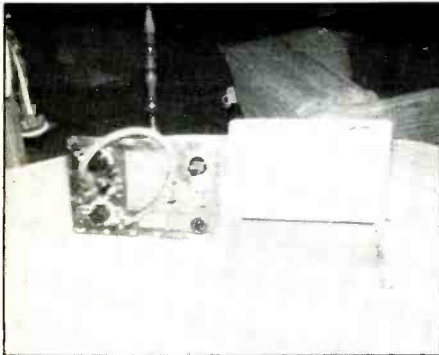

This mystery transmitter, first shown in our May issue, has been identified as a T-784/GRC-109. We knew someone would have the answer!

The transmitter operates from 2 to 12 MHz, having a crystal oscillator and a 2E26 tube as the final amplifier. David, whose code name in the American Cryptogram Association is "Poco," likes to tune in the BCB on his crystal receiver some evenings. He also enjoys listening to WCAU in Philadelphia when the station runs old-time radio shows.

A Rare QSL Card

Around 1950 about 500 QSL cards were printed up for the Alaska Communications System (ACS), a name that replaced the old name—Washington Alaska Military Communication and Telegraph System (WAMCATS). This information comes from M.L. Gibson, W7JIE, of Renton, WA.

WAMCATS was the original organization that provided a link between the "States" and the Alaskan territory during the 1890's Gold Rush days—and later it was expanded in order to provide general communications throughout Alaska in support of the military and civilian population. Eventually it be-

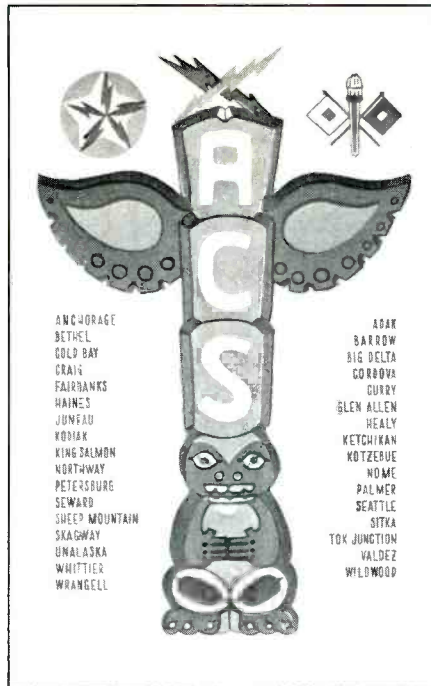

Only 500 of these U.S. Army Alaska Communication System QSL's were printed, and that was back in 1950. It's probable that few still exist.

came the ACS and continued until the 1960's when it was sold to commercial interests.

Starting in the late 1940's, and for about ten years thereafter, ACS even provided broadcast facilities from Seattle to Alaska, with all three networks purchasing time on ACS in order to provide programs to Alaskan listeners. Signals were sent from Seattle in AM mode in the 4, 8, 12, and 16 MHz bands (sometimes with several frequencies simulcasting). Transmitters ran 10 to 40 kW into rhombic antennas. Similar facilities also existed in Alaska, although they were used infrequently.

Prior to the actual program material being sent out, there would be an hour of testing and tuning adjustments made. This consisted of music and voice announcements. DX'ers began reporting these transmissions and asking for QSL's, so the ACS staff had a small batch of attractive red, white, and blue cards made up. Because of the highly directional nature of the rhombic antennas, almost all reception reports came from listeners in the far north. When underwater cables and microwaves came into vogue for carrying the broadcast material, the AM transmissions were discontinued.

As an organization, ACS was a part of the U.S. Army Signal Corps, although it was staffed with civilian as well as military personnel. It was, for many years, the equivalent of both the "Telephone Company" and "Western Union" for Alaska. This was because, in those times, Alaska was considered too remote and too sparsely populated to make it interesting for commercial services. Therefore, the ACS provided long

distance telephone service, data service, telegrams, money orders, broadcast programming, as well as all necessary military communications.

During WWII, about 2,500 personnel staffed this Signal Corps unit, originally designated the 1st Signal Service Co., later changed to the 9427th Signal. Starting in 1941, SSB equipment began coming into use, with RTTY following in 1943. Multiple and other sophisticated systems followed in due course. W7JIE was with ACS as an enlisted man and later as a civilian employee; his service with the organization ran from 1941 to 1959. After leaving ACS, he transferred to the White Sands missile range as Station Chief for a satellite tracking research and development installation.

The rare QSL card from ACS is indeed a treat to have in these pages. It was used to verify the transmissions of stations WLXA, WTJ, WVY, WVD, WXR, WXE, AAH, and others.

Anybody Remember WCX?

Frank Rance, of Sioux Falls, SD recalls that when he was licensed as W9TIM in the 1930's, he got a job at station KRMC in Jamestown, ND—that was just prior to his 40-year career with Western Airlines.

Frank recalls that in 1940 he used to copy Transradio Press station WCX near the 20 and 40 Meter Ham bands. He says this was the method the broadcasters in ND used to get material for their news programs, except that the traffic was sent at 35 wpm! Frank asks if we can find any information on Transradio Press station WCX.



WCX was a short-lived secondary callsign of Detroit station WJR. This 1925 QSL from the old "Red Apple Station" is rather rare. The station's handle was derived from a program known as "The Red Apple Club," that had a nationwide audience.

Alas, in records I could locate for 1940, I couldn't find any press station with the callsign WCX listed near 7 or 14 MHz. Perhaps one of our readers might also remember this station and can fill in the gaps.

As a bit of marginally related trivia, while trying to track down Frank Rance's WCX, I stumbled across earlier stations using that same callsign. In 1915, WCX was a coastal telegraph station in Cleveland, OH. By 1923 the call had been assigned to an early broadcaster in Detroit, MI—"WCX, the Red



One of the featured programs on WCX/WJR was Jan Goldkette and his "Little Symphony Orchestra," shown here tuning up before a broadcast.



In 1925, WCX/WJR had its studios in Detroit's large Book-Cadillac Hotel. The 580-kHz transmitter for WCX/WJR was in Pontiac, MI.

Apple Station" on 580 kHz running 5 kW. The station was owned by the Detroit Free Press and the Jewett Phonograph Co. In those days, this station also used the call WJR. The transmitter was in Pontiac, MI. Eventually, the callsign WCX was dropped and the Detroit station became very well known as WJR, "The Good Will Station." Of course, today WJR is still famous for its 50-kW powerhouse signal on 760 kHz.

Oddly enough, it was easier digging up information on the WCX of the early 1920's than the WCX of 1940!

CBS On Shortwave? Yes!

Give me a show of hands—who remembers when the Columbia Broadcasting System ran a whole bunch of shortwave broadcasting stations from transmitter sites in Wayne, NJ and Brentwood, NY? These stations (most ran 50 kW) operated on a dozen frequencies and existed during the years of WWII and several years thereafter until their services were replaced by the Voice of America.

Those were the days when, in addition to the CBS shortwave stations, there were similar stations operated by General Electric, Westinghouse, NBC, Crosley, and others. The CBS stations used the callsigns WCBN, WCBX, WCDA, WCRC, WOOC, and WOOW. They operated between 6 and 18 MHz, becoming world famous.

Undoubtedly there are a number of their one-card-serves-all type QSL's sitting in the collections of many POP'COMM readers.

WCRC			WCBX	
COLUMBIA BROADCASTING SYSTEM, INC. 485 MADISON AVENUE NEW YORK 22, N. Y. U. S. A.				
1. 6060 Kc. 49.5 M.			7. 1145 Kc. 24.9 M.	
2. 6170 Kc. 48.6 M.			8. 1820 Kc. 25.3 M.	
3. 7820 Kc. 38.3 M.			9. 11870 Kc. 25.3 M.	
4. 9490 Kc. 31.6 M.			10. 15190 Kc. 19.7 M.	
5. 9590 Kc. 31.3 M.			11. 15270 Kc. 19.6 M.	
6. 9650 Kc. 31.0 M.			12. 17830 Kc. 16.8 M.	

Thank you for your recent communication.
This will verify your reception of Columbia's
short wave program on frequency **Mc. 21500 kc.**
on **Sept. 11** 1947

WOOC *Tony Kneitel* **WOOW**
Short Wave Dept. Network Service Dept.

An all-station, all-frequency, all location QSL card was used during the 1940's for CBS' shortwave broadcast stations.

The card shows all six callsigns and twelve frequencies, covering both transmitter locations. A very utilitarian design, wouldn't you agree? Tom Kneitel loaned us just such a card, one of those garnered from his early days at the dials.

Pipe Dream

Those of you who smoke a pipe are probably familiar with Edgeworth Tobacco. I'm familiar with Edgeworth because (speaking as a passive observer) it's the only brand that doesn't cause me to gasp when I'm in a room where people are pipe smoking—this is NOT a paid endorsement!

Edgeworth Tobacco came to mind when we received a note from Dr. Harold Cones, Newport News, VA. Doc was at a flea market and found a QSL letter dated 1930 from

Kind Friend:

Your report on our recent radio program has been received, and we thank you very much for this courtesy. We share with those who entertained you the satisfaction that their efforts have pleased, and we will be very grateful for your future comments as often as your convenience permits.

Cordially yours,
LARUS & BRO. CO., Inc.

WRVA/ED

PATRONIZE THOSE WHO ENTERTAIN YOU!

"EDGEMORTH" HIGH GRADE TOBACCO

WRVA sent this QSL letter to a listener in 1930. One of our readers found it at a flea market 57 years later!

station WRVA ("Where The South Begins") in Richmond, VA. The station's attractive letterhead was not at all bashful about being owned by Larus and Brother, Co., Inc., manufacturers of Edgeworth brand tobacco. This company began producing Edgeworth in 1903 and still owns the brand, although now the finished product is

produced in Tucker, GA and sold in more than 70 nations.

Announcing its slogan "Carry Me Back To Old Virginia," WRVA arrived on the air in late 1925, running 1 kW on 1170 kHz. By 1929, WRVA had moved to 1110 kHz with a new 5-kW rig. Shortly before WWII, the station moved to 1140 kHz with a 50-kW transmitter located at Edgeworth, VA. The studios were in the Hotel Richmond.

Dr. Cones tells us that WRVA today presents a mixed program format. One of their more popular programs takes place in the evening from a truck plaza on the outskirts of town. They play music for the truckers driving in the eastern states, provide road condition information as well as other tidbits useful to their on-the-move audience.

Thanks to Dr. Cones for submitting this QSL letter. Dr. Cones, by the way, is President of the Great Circle Shortwave Society.



The 1925 Wellesley College (Massachusetts) Radio Club. The question is, did they ever get the transmitter on the air?

School's In

What with the school year beginning again, though you'd like to get a look at the Wellesley College Radio Club as it looked in 1925. This was slightly before my undergrad attendance at that noble institution. The two Physics Department instructors (Lucy Begeman and Louise McDowell) are standing to the left. At the right are three members of the club. The hardware shown is the makings of a 50-watt CW transmitter that the group was hoping to assemble and put on the air. That's the way it was done in Massachusetts 62 years ago; let's hope they eventually got a license for their station!

All Talking

Just in case you were wondering, *The Jazz Singer* wasn't a musical sewing machine. It was the title of the first "talking" picture, a feature that was released in 1927. It didn't happen overnight, and the popularity of broadcasting seemed to give the studios the clue that movies would have to start talking in order to lure audiences away from the joys of tuning in distant broadcasters each night.

Warner Brothers Motion Picture Studios (producers of *The Jazz Singer*) took no chances, and in March of 1925 put their own radio station on the air. That was KFWB, 500 watts on 1190 kHz, a few issues

Historic Ham QSL's

In Africa, Eritrea formed part of the ancient Ethiopian kingdom of Aksum until the 7th Century. It remained independent until the mid-16th Century, when the Ottoman Empire occupied most of the coastal region. In the mid-19th Century, both Egypt and Italy attempted to gain control of Eritrea, and by 1890 Italy finally won out and proclaimed the area as an Italian colony. The colony was later (1935-36) utilized as the staging area for Italy's takeover of Ethiopia.



Eritrea was captured from Italy by the British in 1941 and, as of 1949, administered the areas as a U.N. Trust Territory. For ten years, starting in 1952, Eritrea was a federated part of Ethiopia, ultimately voting to end that status and completely unify with Ethiopia.

Prior to WWII, Eritrea had no Ham Radio prefix assigned, but by the end of WWII the occupying military forces brought Ham Radio to the area. Right after the war, the area's operators were using an I6-prefix and an MI6-prefix. By 1950, I6 was still in use, but MI6 had been replaced by MD3 and MI3—a status that remained intact when MD3 was replaced with ET2. Ultimately, ET2 was used by all stations after the mid-1950's and until the nation lost its separate identity and DXCC country status in November of 1962.

Reader Clarence N. Zornes, W9TAL, of Chicago, was kind enough to remind us of almost-forgotten Eritrea. In 1947 he contacted station I6USA, operated by U.S. Army personnel at Asmara. The QSL verifies a 14-MHz CW contact while I6USA was running a 600-watt BC-447 transmitter.

It's been a quarter of a century since anybody's been able to claim credit for a separate country for contacting Eritrea. Clarence's 1947 contact beat the deadline with plenty of room to spare! Clarence is a member of the QCWA and the OOTC.

Keep sending items for our little history corner—everything is appreciated!

back we ran two early photos of KFWB.

One of the more interesting aspects of KFWB's operations was that it had a fully-equipped mobile broadcasting studio that could provide remote programs. It turned up at theaters for gala "World Premiers" and other Hollywood caliber events.

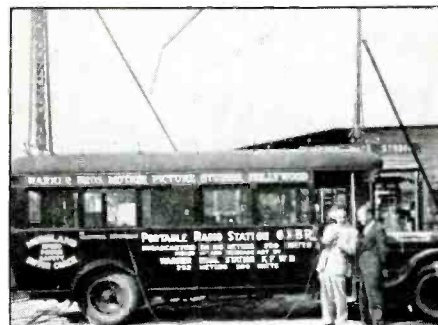

In 1926, Hollywood's KFWB had a remote van that was a complete portable broadcast studio and station. It was licensed as 6XBR and ran 250 watts on 2778 kHz. The programs were picked up and rebroadcast through the KFWB 500-watt 1190 kHz transmitter.

This mobile studio was installed in a large Moreland Motor Coach bus and was actually a complete portable broadcasting station unto itself. Large hinged masts mounted on the roof of the bus could be raised to support the antenna system. This station was assigned the Experimental callsign 6XBR. It

had a 250-watt transmitter operating on 2778 kHz.

A photo we have of W6XBR shows KFWB's Manager and Chief Announcer (light suit) showing the station to Frank H. Murphy, Warner's Chief Electrician. This was taken in early 1926.

Alice Asks . . .

The photos, QSL's, news clippings, and other vintage communications and broadcasting contributions to this section of POP'COMM are sincerely appreciated. Please keep 'em coming! **PC**

In the May column we mentioned AM-mode Ham operations. That brought in a letter from Larry Lowry, WD5CFJ, who notes that he's a diehard AM'er. He and several pals, including K5SWK, WA5BXO, WA5TWF, KA5FPV, and others hang out from time to time on 3885 kHz. Larry would like to get a regular monthly AM-mode net going on 3885 kHz and would like to hear from those who'd like to participate. Contact him over the air, or drop him a card or letter at 1014 Postoak Road, Willis, TX 77378. Sounds like a good idea to us—and one of these AM'ers, KA5FPV, is the Program Director and a DJ over AM broadcaster KIKR (880 kHz), probably an interesting guy with lots of answers to the questions everybody seems to have about broadcasting. —Alice

A Revolutionary New Concept In Scanners

Regency Informant Mobile Scanner Provides Completely "Hands-Free" Monitoring

BY F.X.F., NORTH DAKOTA

Scanning can be a fascinating, yet frustrating experience. Anyone who's had to sort through the hundreds, even thousands of allegedly "active" VHF and UHF frequencies used in a city or metro area, knows the tedium of programming a 40- or 50-channel scanner, only to find out that 20 or 30 of the frequencies aren't even being used!

That's what makes a receiver such as the Regency Informant so appealing.

Available from Regency Electronics, Inc. (7707 Records Street, Indianapolis, IN 46226), the Informant is a special mobile receiver that is programmed with the key state and local law enforcement frequencies for all 50 states.

Designed for installation in cars, trucks and RV's, the Informant truly takes the guesswork out of scanning. Simply turn it on, select the state you want to monitor, and it starts scanning. It's that simple.

Developed For Trucker Market

Originally developed for the trucker market, the Informant is ideal for anyone who likes to do their monitoring on the road. And, since it already is programmed with the active state and county police frequencies from three bands (VHF-Low, VHF-High, and UHF), it has an immediate edge over other mobile scanners on the market.

Imagine this scenario: You're traveling cross-country in your BMW and you want to use a scanner to keep track of road conditions, accidents, speed traps and other tidbits of information. As you leave Virginia and enter West Virginia, you pull over to a rest stop, open a frequency directory, and begin programming in the key West Virginia state police and county police frequencies.

Fifteen minutes later, you're back on the road. But, are the frequencies you programmed active? Maybe. Maybe not.

With the Informant, as you travel from state to state, you simply flip a switch to change frequencies for a new state. In a few seconds, you're monitoring the active frequencies you need to keep track of.

If that sounds like a more convenient way of scanning, you're right, it is.

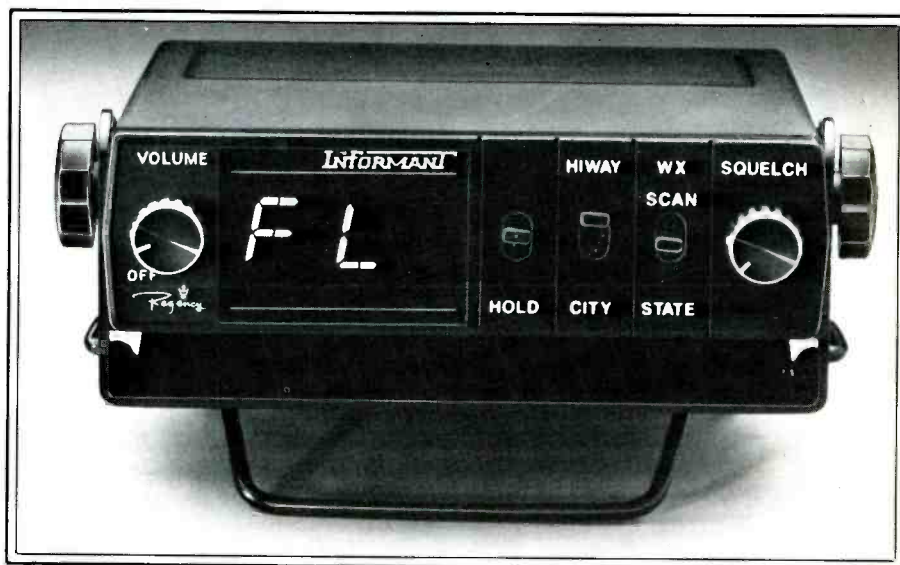

The new Regency Informant Public Information Radio is completely pre-programmed, by state, to receive any type of police transmission in the standard VHF and UHF bands.

To insure that the frequencies stored in the Informant's databank are accurate, Regency spent over one year researching active VHF and UHF frequencies. During this time, scanner listeners in all 50 states were consulted, as were the very latest frequency directories and FCC files.

Once the data was sorted, Regency engineers compared the data to additional data compiled by several truckers who conducted cross-country runs with the Informant. Only after all of this information was accumulated was the software written and programmed into the receiver.

As a result, with the Informant, there are virtually no frequencies to program. The Informant knows which frequencies are active both state-wide and locally. And, should any of the frequencies be changed, Regency will offer users a frequency upgrade for \$50—the Informant will never be obsolete.

First "Public Info Radio"

Regency doesn't even call it a scanner. Instead, the Informant is referred to as the world's first "Public Information Radio."

Regency believes that the Informant will appeal to anyone with an interest in monitoring police bulletins.

Since it's designed for use in vehicles, the receiver is lightweight and extremely compact. The radio measures just 1 $\frac{3}{8}$ "H × 5"W × 6 $\frac{1}{2}$ "D and weighs less than a pound. In fact, at first glance, it almost looks like a radar detector.

Although it can be hard-wired directly into a vehicle's DC system, the receiver also comes with a cigarette lighter cord (an optional AC adapter is also available for home use).

With the cigarette lighter cord and the optional Regency MA-547 magnet mount antenna (\$49.95 direct from Regency), you can be scanning in seconds . . . even in a rental car.

Appearance-wise, the Informant combines sleek styling, with an uncomplicated front control panel, plus a top-mounted speaker that delivers plenty of audio (1.5W at 10% or less distortion), even when the windows are open.

Here's how the Informant works. On the

front panel is a volume control (which also turns the unit "on" or "off"), a digital display [which shows the state being monitored, as well as the type of broadcast being monitored—"SP" for state police, "CM" for county mounty, "BA" for bear in the air (police aircraft), "WX" for weather, or "HO" for hold.]

Next to the LED display is a hold switch, which locks the receiver on a preferred frequency, a "hiway/city" switch for selecting between state police and county police frequencies, a "weather scan/state" switch for either changing the state, or for instantly searching for the active U.S. or Canadian weather frequency, and a squelch control.

That's it. While hardcore scanner buffs might be disappointed by the fact that there aren't scads of controls to tweak and twiddle, for someone like myself, who simply wants to keep track of the action, the radio is ultra-easy to use. In fact, in seconds, anyone can operate the Informant.

Technology Breakthrough

Even though the Informant is designed for the masses, that doesn't mean it won't interest long-time scanner enthusiasts.

Due to a patented new technological breakthrough in scanner design called "TurboScan," the Informant searches out active frequencies at a rate of up to 50 channels per second. By comparison, many scanners work at a speed of 10 or 15 channels per second.

What does this speed mean to you? Since the average length of a typical police bulletin is about three seconds, "TurboScan" means you'll be able to follow even more bulletins.

The Road Tests

I've had the opportunity to road test this unique receiver on two occasions, and both times, I've found it to be an immensely helpful and informative tool.

For the first test, I drove from Bismarck to Minneapolis and back. During the course of my 800-mile trip, the Informant saved me at least one ticket. I was zipping down I-94 when I heard a state police officer setting up a radar trap. Sure enough, when I arrived at his location five minutes later, there he was, with his radar gun pointed at me!

On another trip, from Chicago to St. Joseph, MI, the Informant saved me from being stuck in a traffic jam.

Just two miles over the Michigan state line, the state police frequencies came alive with the news that an 18-wheeler blew a pair of tires and was disabled, causing a traffic tie-up in the right and middle lanes.

Since I knew about the incident miles before I reached it, I stayed in the left lane and zipped by the disabled truck, while other vehicles were stuck behind it.

The Informant's blazing scanning speed and extensive database of frequencies aren't the only features that make it unique. The receiver's outstanding selectivity (± 7 kHz at 6 dB and ± 18 kHz at 50 dB) allows

for optimum use, even in congested areas of the city.

In addition, on the open road, the receiver's exceptional sensitivity (0.35 μ V on VHF-Low, 0.45 μ V on VHF-High and 0.50 μ V on UHF) provides reliable long distance reception. With the optional MA-547 magnet mount antenna, I have no problem monitoring area frequencies from my location in the boonies. Furthermore, while Regency claims a reception range of 50 miles away, I had no trouble monitoring frequencies from as far as 100 miles away. (As an aside, a photojournalist friend of mine who uses the Informant on the West Coast reports that he has no problem monitoring San Diego police frequencies from his location in Los Angeles.)

The Bottom Line

The Informant won't necessarily bring you a transmission that you can't hear by using a conventional scanner, its combination of ease of use and performance makes it an exceptional performer in the car.

The Informant retails for \$369.95 and is available at truck stops throughout the country, as well as from the Sears catalog. As additional units are manufactured, the unit also will be available through traditional consumer electronics outlets.

If you've ever thought of adding a mobile scanner to your truck, car or RV, consider installing an Informant.

PC

BEE ELECTRONICS

Introduces **Scanner Cases!**

High Quality Leather Cases For Scanners To Fit:

- Realistic PRO 30, PRO 32
- Regency HX 1000, HX 1200, HX 1500

Get the same high quality leather cases that we supply to the commercial two-way portable market, for your scanner.

Made From:

- High Quality Full Grain #1 Grade Leather.
- Heavy Duty Nickel Plated Brass Hardware.
- Genuine "Pull The Dot" Fasteners.
- Available With T-Strap or Full Cover for Maximum Protection.*
- All Models Available With or Without Quick Disconnect Swivel At Additional Cost, Which Allows the User to Remove Radio and Case from Belt.
- In Stock for Immediate Delivery.

Special SALE Price!!!

\$37.00 + Shipping and Handling
Protect Your Scanner with a Quality "BEE" Case.

*Models Regency HX 1000, HX 1200, HX 1500 only

Call Today Toll FREE 1-800-336-3115



BEE ELECTRONICS, INC.

2655 Gardner Road • Broadview, IL 60153
(312) 345-0337

**YOU
AIN'T HEARD
NOTHIN'...YET!**

Since 1967, CRB Research has been the world's leading publisher and supplier of unique hobby and professional books and information including:

- Scanner Frequency Guides
- Shortwave Frequency Guides
- Military/Federal Communications
- Broadcast Station Registries
- Undercover Communications
- Survival Communications
- Covert Operations
- Electronic Espionage
- Surveillance
- Monitoring
- Cryptography & Codes
- Bugging
- Wiretapping
- Communications Antennas
- Electronics & Projects
- Fox Scanner Directories
- Computer Technology
- & Other Related Topics!

**THE 'TOP SECRET'
REGISTRY OF
U.S. GOVERNMENT
RADIO FREQUENCIES**

25 TO 470 MHz

BY TOM KNEITEL, K2ARS

6th Edition

New titles are constantly being added to our exciting catalog. If it's interesting and unusual, we've got it. You'll see! Ask for our latest FREE catalog.

CRB RESEARCH

P.O. Box 56 Commack, NY 11725

CIRCLE 93 ON READER SERVICE CARD



BOOKS YOU'LL LIKE!

BY R. L. SLATTERY

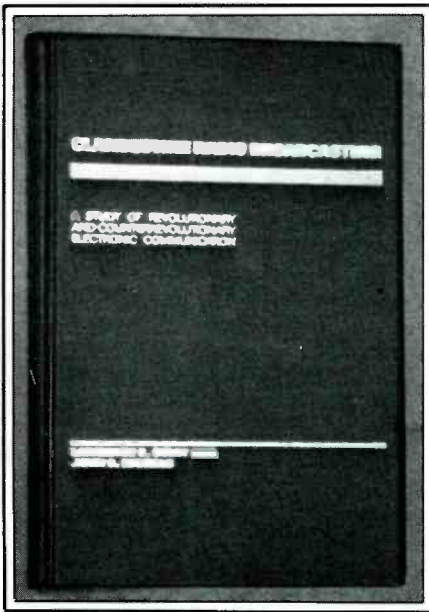

Clandestine Topics

The new book *Clandestine Radio Broadcasting*, by Lawrence C. Soley and John S. Nichols, describes itself as "a study of revolutionary and counter-revolutionary electronic communication." That it is—is it ever! This is extremely probing and in-depth text, a full 384 pages in length and in a hardcover binding (with silver stamping, no less).

The authors are both college professors in the field of communications. Their work is a rather scholarly treatise targeted more towards those studying political science and international communications than a book aimed squarely at the casual DX'er. While it doesn't contain any frequencies or photos, it contains more hard information on its unusual topic than had ever previously been collected and analyzed.

In eleven totally engrossing chapters, Soley and Nichols reach back into the early 1930's and pick up the threads of broadcasters from the political underground and then take you through this eerie world through WWII, the Cold War, and into the present. Just about all significant stations, personalities, and incidents are discussed and explained at length. Special chapters devote extra attention to Radio Espana Independiente, Castro and the Caribbean area, East Asia, and the current crisis in Central America.

After a general discussion of clandestine broadcasting, in which the authors present their conclusions, three extremely valuable appendices are provided. One is a large list of all known clandestines from 1948 to

1967, giving the stations' names and sponsors/ideologies. Next, a similar list provides similar information for the years 1971 to 1985. Lastly, there is a lengthy analysis of the Voice of Palestine and related broadcasts. A large reference bibliography is also provided.

DX'ers reading this book will be most impressed, as was I, by the fact that the authors have researched their subject so well that they have even utilized hobby sources for their information—quoting from Gerry Dexter, Tom Kneitel, Harry Helms, and *Popular Communications* right there along with quotes from CIA and advanced political reference works.

This is an excellent and well done book that tackles this most interesting subject with fine insight and objectivity, then presents the material in an informative manner that never ceases to be totally engrossing.

For those who want to peer into the history and inner workings of worldwide clandestine political broadcasting, this looks like it's the definitive work on the topic. While it is not primarily aimed at the DX hobbyist, it will offer the serious listener an extremely worthwhile guide to an always-absorbing aspect of international radio.

Clandestine Radio Broadcasting is \$47.95. It comes from Greenwood Press, 88 Post Road West, Box 5007, Wesport, CT 06881.



Start At The Beginning

The intent of *So You Bought A Shortwave Radio!* is to get someone started from scratch in the SWL hobby. That is to say, you could give this 74-page book to someone who thought shortwave was either a ladies' hairdo or something to surf on—by the time they read it they'd have a basic grasp of the major factors involved in the DX hobby. It's written so that it will be useful to an adult while still being within the understanding of a 12-year-old.

In a light and readable non-tech style, it offers capsulized information on what

DX'ing is, some of the different listening specialties, an explanation of receiver features and panel controls, international time, antennas, where to shop for equipment, clubs, Ham radio, SWBC stations, frequency bands, and other types of ground-floor information.

Gerry Dexter has crammed a lot of information into this little book, and managed to sugar coat it just enough so that it isn't intimidating. What with sunspots resuming their climb and bringing back better DX'ing conditions, this book may have come along just at the right time to help newcomers ease into the ranks of the DX'ing hobby.

It's a nicely done book containing lots of source addresses to help the rank beginner find his/her way painlessly along the first steps of a path that they'll certainly find dazzling. If you can remember your feeling of confused excitement the first day you confronted a communications receiver, then you can fully appreciate the potential of this book.

While there are no photos in the book, it contains plenty of relevant cartoon illustrations which are most imaginative, although drawn in a non-professional style. In all, *So You Bought A Shortwave Radio!* is an upbeat and constructive entry that serves a worthwhile purpose.

The book is \$6.95 per copy. It's from Tire Publications, P.O. Box 493, Lake Geneva, WI 53147.

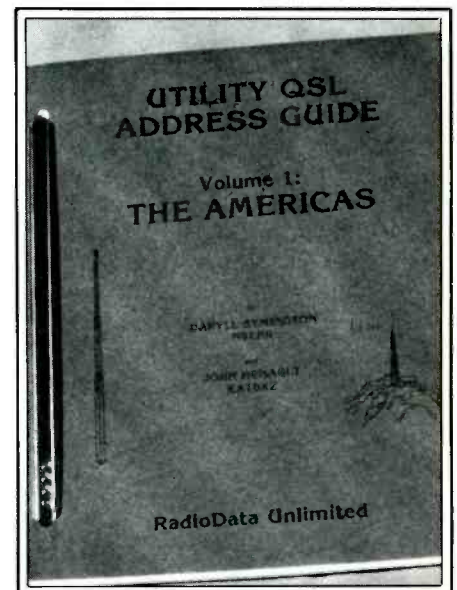

Ute Like This One!

Daryll Symington (N8EBR) and John Henault (KA1OXZ) have gotten together

POPULAR COMMUNICATIONS



and done a new book entitled *Utility QSL Address Guide, Volume 1: The Americas*. Daryll, of course, is the "ute" station editor for the All Ohio Scanner Club, and a regular loggings contributor to the columns in *POP' COMM*.

Daryll and John have devoted the better part of a year to compiling, verifying and editing a quality reference source for the DX'er who monitors voice, RTTY, and CW stations operated by/for military, press, maritime, aeronautical, governmental and similar communications purposes. This large-format (8½" x 11") book runs 100 pages and covers more than 4,500 station addresses in North, Central and South America as well as Caribbean areas. It also has an equal amount of callsigns, plus interesting text relating to the many categories of stations covered, as well as tips and techniques for obtaining QSL's.

Plenty of addresses and information that have never before shown up anywhere make this a most useful book, especially in the area of military and federal civilian stations. The inclusion of station callsigns makes this, in fact, a callbook as useful for identifying stations monitored as it is as a directory of addresses for QSL'ing purposes. Even if you aren't interested in QSL'ing these stations, it's a unique and comprehensive ute directory of callsigns, locations and station owners.

The directory has extensive listings of addresses of airlines, cruise lines, state Civil Defense agencies, time/frequency stations, and all sorts of other delights such as FCC monitoring station callsigns and addresses, FAA Air Route Traffic Control Stations, NOAA addresses, USN and USCG callsigns for ship and shore facilities. Just lots and lots of hard information from cover to cover compiled by people who have taken much care in being comprehensive and accurate. Daryll notes that a *Volume 2*, covering "the rest of the world" is presently being readied for release.

The book is handily done up in a 3-hole-punched format that you can use with your own 3-ring binder, or you can leave it bound with the removable metal binder that is provided. This format will permit easy updating in the future.

A reference guide that every ute monitor will find to be an invaluable data source, the *Utility QSL Address Guide, Volume 1: The Americas* is available at \$12.95 per copy plus \$1 postage/handling (to addresses in the USA/Canada/APO/FPO) from CRB Research, P.O. Box 56, Commack, NY 11725.

PC

Here's what you've been looking for – an all new hard-hitting monthly magazine which gives a unique insider's view of what's really going on in the world of communications. **POP' COMM** is your primary source of information – bigger and better than any communications magazine, with exciting coverage of scanners, shortwave broadcast & utility stations, spy stations, pirate and clandestine broadcasters, RTTY monitoring, survivalist communications systems, FCC news, wiretapping and bugging, voice scrambling/unscrambling, surveillance/undercover communications, satellite & cable TV, sophisticated telephones, & more. What you've been looking for all along! Take advantage of substantial savings over the newsstand price by subscribing now. Don't miss out on even one single issue of **POPULAR COMMUNICATIONS** – order your subscription now.

**Twelve
Issues
\$16**

SUBSCRIBE NOW & SAVE!

POPULAR COMMUNICATIONS

76 N. Broadway, Hicksville, NY 11801

Yes! The **NEW POPULAR COMMUNICATIONS** is just the magazine I've been looking for. Start sending it to me now! I understand that I may cancel at any time for any reason, and receive a full refund on my unused subscription.

Paid by: Check Money Order MasterCard Visa
My account number is:

--	--	--	--

Name _____
Street _____
City _____ State _____ Zip _____

- 1 year - 12 issues \$16.00
(Save \$14.00)
- 2 years - 24 issues \$31.00
(Save \$29.00)
- 3 years - 36 issues \$46.00
(Save \$44.00)

Canada and Mexico - one year \$20.00 US, two years \$39.00 US, three years \$58.00 US. Foreign - one year \$22.00 US, two years \$43.00 US, three years \$64.00 US.

A Great Gift Idea

Send the following gift subscription to my friend at my expense.

Please indicate your name above. A gift card will be sent.

Paid by: Check Money Order MasterCard Visa
My account number is:

--	--	--	--

Name _____
Street _____
City _____ State _____ Zip _____

- 1 year - 12 issues \$16.00
(Save \$14.00)
- 2 years - 24 issues \$31.00
(Save \$29.00)
- 3 years - 36 issues \$46.00
(Save \$44.00)

Canada and Mexico - one year \$20.00 US, two years \$39.00 US, three years \$58.00 US. Foreign - one year \$22.00 US, two years \$43.00 US, three years \$64.00 US.

The Life And Death Of Radio Biafra

BY DON JENSEN

Biafran Background

Nearly a century ago, the colonial powers met in Berlin to divide the West African spoils. To Britain went Nigeria, an uncohesive land of feuding tribes. London provided the glue that held it together. But with independence in 1960, Nigeria became unstuck. Tribal jealousies triggered coups, assassinations and, in 1966, the mass murder of 30,000 ethnic Ibos.

The Ibos are a remarkable people, ambitious, industrious and educated. Convinced they were marked for genocide at the hands of rival political forces, eight million of them sought refuge in their traditional eastern homeland. There, in the city of Enugu, on May 30, 1967, Biafra's independence was proclaimed.

The Nigerian government promised to end the rebellion with "swift, surgical police action." But for nearly three years, the usually outgunned but seldom out-fought Biafrans held out, though driven into an enclave one-tenth its original size. Cut off from the outside world, the Ibo talent for improvisation paid off. From their home-refined gasoline — only a bit more potent than Biafran "survival gin" — to their hand-rolled cornsilk cigarettes, they proved necessity the mother of invention.

With an urgent need to influence the outside world, Biafra placed a high priority on radio broadcasting. This is the amazing story of that effort.

However, it was a lost cause. Eventually, Biafra was forced to surrender on Jan. 12, 1970. The aftermath of the war was surprisingly free of bloodshed and, within a few years, the ethnic Ibos were more or less reintegrated into Nigerian national life. Today, Biafra is again part of Nigeria, where the struggle for stable nationhood continues, as does a lingering mistrust among the tribal elements.

Hundreds of thousands had already died, mostly by starvation, in the 800-day-old Nigerian civil war. But against long odds and short rations, the Biafrans still fought on during the summer of 1969.

Day began early in Biafra. In Orlu, the provisional capital since April, truck convoys, loaded with supplies flown in during the night, rumbled in from the makeshift airstrip at Uli, 18 miles away.

Not far from town, radio engineers warmed up a shortwave transmitter. A rhythmic

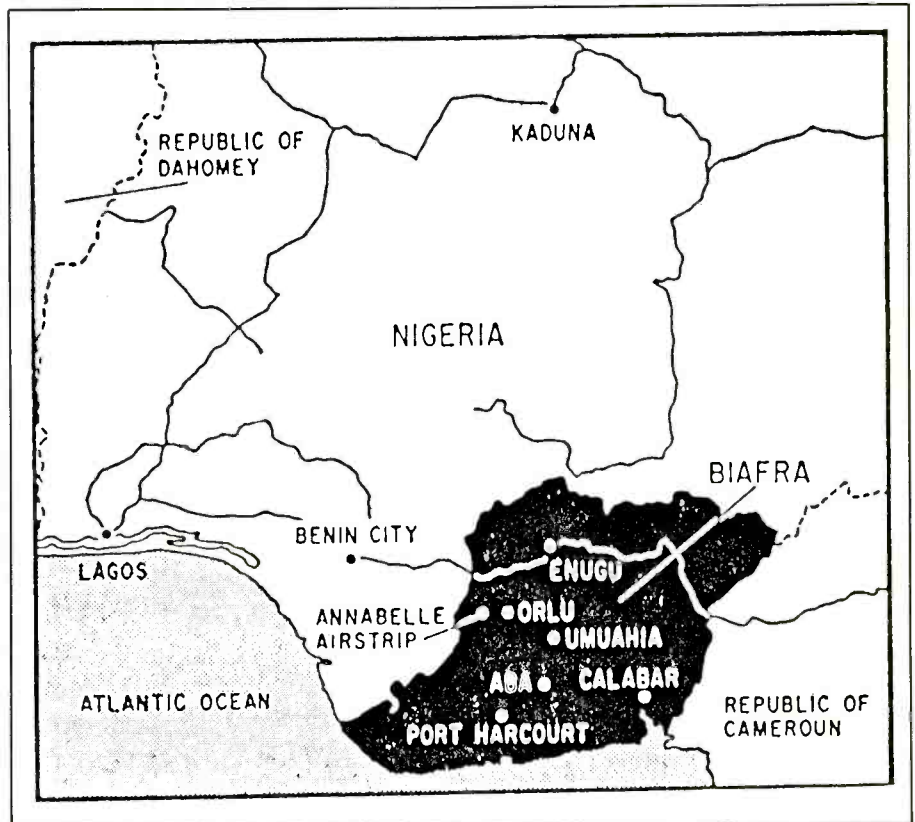

tuning signal radiated across the African farmland.

In the tin-roofed town, Biafrans awoke to the sound of tramping feet and the abrasive shouts of drill sergeants counting cadence. Thousands of receivers were switched on.

"This is Radio Biafra, the home service of the Broadcasting Corporation of Biafra. The time is 25 minutes before 6, and we are broadcasting in the 41 meter band. We invite you to join in our morning devotional service."

That morning, as on hundreds of mornings before, Biafrans, two-thirds of them Christian Ibos, arose listening to hymns and prayers from Radio Biafra. Most would have no breakfast that day. Their faith would have to sustain them.

By 6 a.m., a second transmitter was on the air. It was the Voice of Biafra, the over-seas service, beaming a newscast to the outside world. Most Biafrans, though, were listening to the domestic channel for the "Early Bird" program, a wake-up show with fanfares, pep talks and rousing music.

"Say it loud!" exhorted announcer Okoko Ndem. And throughout the still sleepy countryside, his audience shouted back

at their radio speakers: "I'm Biafran and I'm proud!"

For the BCB's chief engineer, A.S. Alaribe, formerly senior sound technician for the Eastern Nigerian Broadcasting Service in pre-revolutionary days, it had been months of scrounging spare parts in a dwindling local market, somehow keeping his transmitters together with spit, string and sealing wax. It was an equally tough time for program writers and announcers, veterans of broadcasting in Lagos and Enugu before the war. Probably not since World War II had a station tried to operate under such difficult conditions.

Broadcasting in Nigeria dated back to 1936, but the first station in the eastern region of the country wasn't installed until after WWII. When the civil war began, there were two stations in Enugu, the provincial capital; the central government's Nigerian Broadcasting Corp. outlet and a commercial station, Eastern Nigerian Broadcasting Service. With the revolution, both were taken over by the Biafran government.

When the paper rebellion became a real war in July 1967, Biafran radio had been operating for a month, with its home ser-

vice on 3980 kHz; the foreign service on 4855 kHz.

Nigeria's opening offensive stalled, and when it did, the hastily trained Biafran troops pushed forward, startling the national capital, Lagos. Benin City, in adjoining Midwest State, was captured and, for a month or so, a newly proclaimed Republic of Benin allied itself with Biafra.

Then, in September, the larger and better trained Nigerian Federal Army surged ahead, recaptured Benin City and moved toward the Biafran capital of Enugu. The 33-year-old Biafran leader, Chukwemeka Odumegwu Ojukwu made plans to evacuate his revolutionary government to safer ground. The word came down to the Biafran broadcasters from Dr. Ifegwu Eke, the commissioner of information—"Pack up and move out!"

The three transmitters, two shortwave and one mediumwave, were big and bulky. But contingency plans for the move had been made in advance. Main switches were pulled and the dismantling work began.

Enugu would fall to the Nigerian army on Oct. 4, but a week earlier, a truck convoy left the city, headed for Aba, 120 miles south. With headlights dimmed, a string of lorries followed black-topped Highway No. 3 through Awgu and Okigwi. There the road bulged west and crossed the Imo River. Then it straightened southward again to Umuahia and, after a 37 mile stretch, the trucks rolled into Aba.

In the new capital, Biafran radio was rebuilt. Its new antennas already were up. The 4855-kHz station was back on the air just 72 hours after it had shut down. Two weeks later, the other shortwave station, its frequency now changed to 6145 kHz, was reactivated as the Voice of Biafra. However, this move, and two subsequent ones, were never announced. To the end, the BCB maintained the fiction that it was still located at Enugu.

Broadcasting continued despite problems. Tubes failed; tape recorders sputtered and stalled. Apologetic announcers broke in to advise that, "until we can continue with the broadcast, here are some records."

A major interruption occurred on April 4, 1968, and lasted two days. Nigerian Air Force Ilyushin jets dropped eight bombs on Aba, destroying buildings and killing 36. The station, which was scoring a propaganda impact abroad, had become a key military target. The Lagos government also tried, without much success, to jam the stations beginning in July.

The Nigerian Army was having more success though. On September 4, Aba fell. But, just one jump ahead, the radio stations were moved northward to Umuahia, a shift accomplished in just 36 hours.

For the young republic, things hardly could have been worse. Its territory had shrunk drastically. The rickety air force had long since been shot out of the sky. Its troops were lucky to go into combat with more than

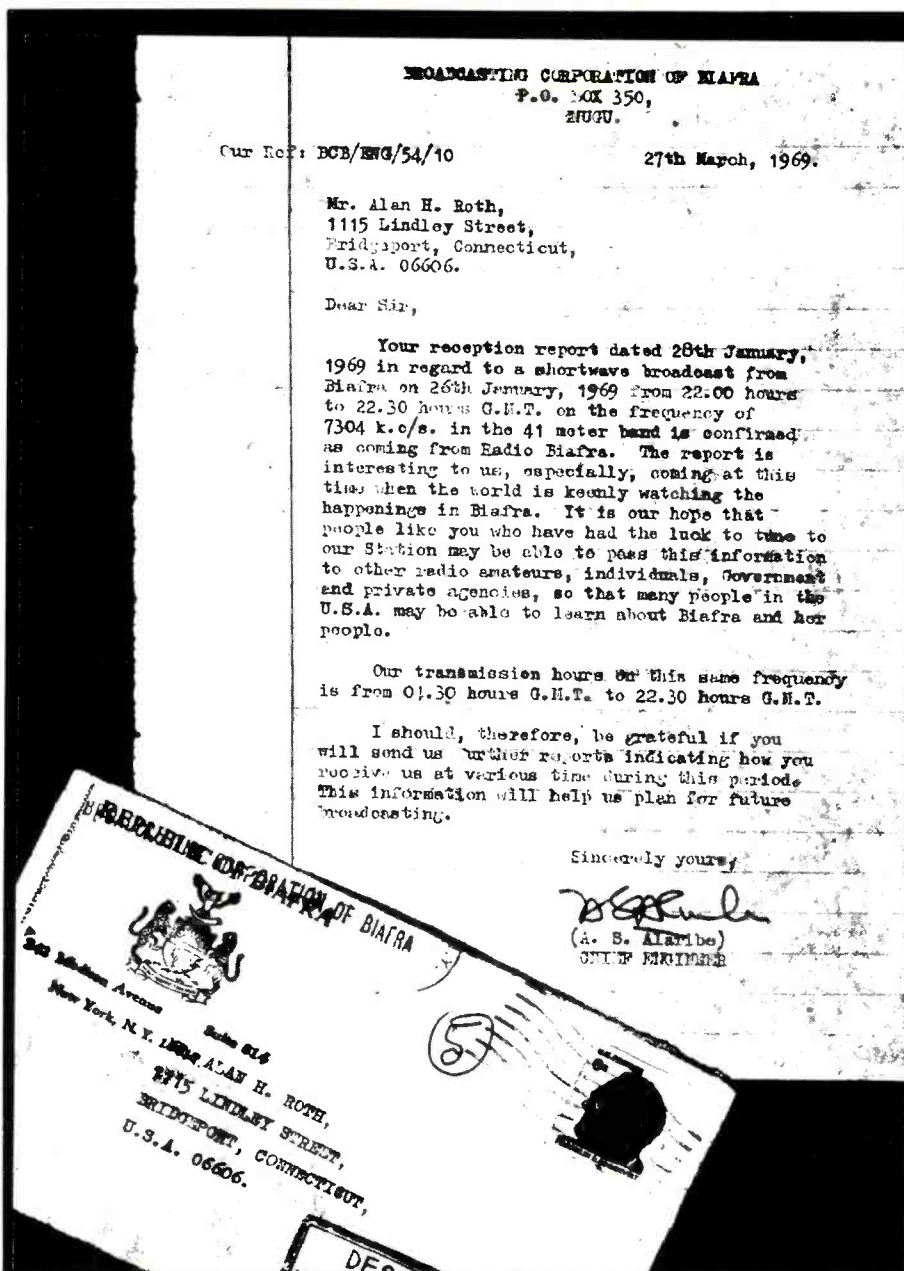

Only known QSL direct from Biafra, received by Alan Roth, now of New York City. Roth took his report to the NYC office of Biafran delegation, which managed to get it flown into the breakaway nation, with other official correspondence, on the emergency airlift. Radio Biafra's chief engineer wrote the verification letter and returned via the same route. It was mailed to Roth from New York. A high-contrast photo was required to bring out the typing since a well-worn typewriter ribbon had been used.

a bullet or two each. Civilians were dying, thousands each week, from starvation.

Then two things happened to change the picture. International relief flights began arriving with food to stem the starvation, and France's president, Charles DeGaulle, decided to help Biafra. An officially unofficial French airlift, via her former colonies of Gabon, Dahomey and the Ivory Coast, brought in arms and ammunition to shore up the tottering regime.

One afternoon in October 1968, an antiquated DC-4, one of eight planes on the Gabon-to-Biafra run, stood on the tarmac of a military airport at the edge of the sea, seven miles from Libreville. Under the wat-

chful eyes of French security men, sweating Gabonese workmen loaded the aircraft. An hour later, the flight crew, three Frenchmen, drove up in a tiny Citroen. By 6 p.m., their plane was airborne, on its way to Uli in beleaguered Biafra, 450 miles away. Usually these flights carried long, rope-handled ammo boxes and army rations. That evening, the cargo was different.

A half-hour out of Annabelle, the code name for the Uli landing strip, cabin lights were switched off. Landing flaps lowered, the plane descended through the warm darkness. Parallel rows of runway lights flashed on below. The DC-4 settled bumpily on the widened strip of highway that served

as Biafra's emergency international airport. Immediately, the field's lights went out.

A Biafran ground crew skillfully and swiftly shifted the large crates from the aircraft to waiting trucks. Two hours and 60 miles later, the special cargo arrived at its destination, a hidden transmitter site just outside Umuahia.

In the wooden crates were a brand new shortwave transmitter and a gas-fueled generator to power it. The compact, 10-kilowatt transmitter had been purchased secretly by an intermediary company from the Swiss electronics firm of Brown, Boveri and Co., Ltd.

The Baden, Switzerland electronics manufacturer refused to divulge any information about the sale. Except for the covert French aid, Western nations remained neutral or supported the Nigerian government in the civil war.

Later there were reports that the purchase had been arranged by a couple of Zurich businessmen. Those two wheeler-dealers, by the way, later had a shortlived success with another broadcasting venture, a high seas pirate shortwave station aboard a ship in the North Sea.

The Biafrans were more talkative than the Swiss. The newly acquired transmitter, they explained, was converted to portable operation by their own technicians. Before long

it was operating on a new frequency of 7304 kHz (it would vary, in coming months, from about 7300 to 7312 kHz), replacing the outmoded home service station, which was retired from service in the 60 meter band.

The overseas service Voice of Biafra continued to use one of the remaining older transmitters. It operated briefly on 6100 kHz, but then returned to 6145 kHz. It was installed in what was supposed to be a permanent site, a converted home outside Umuahia, and was connected to a directional antenna, beamed west. The new transmitter, for the home audience, was linked to an antenna beamed eastward. The portable unit was parked nearby.

A mile away, studios and administrative offices were located. Broadcasts were written and prepared by no less than 40 separate groups, including prominent Ibo university lecturers. One group produced three different "Newstalk" shows a day. The "Outlook" committee turned out six scripts daily. Much of the material was recycled in the official "Biafra Newsletter" publication.

The favorable publicity Biafra received abroad was the result of a slickly operated propaganda effort.

It was reported that one volunteer on the staff was bestselling novelist Frederick Forsyth, author, in later years, of the based-on-fact thrillers, *The Day of the Jackal*,

The Odessa File, and *The Dogs of War*.

Forsyth had been sent as a BBC reporter to cover what was supposed to be "a small, ten-day war." His reports of the plucky efforts of the Biafrans "angered some mandarins in the (British) Foreign Office," he later told an interviewer from the French weekly, *Le Nouvel Observateur*.

Forsyth, who admitted to being a champion of just causes, was recalled from Africa by the BBC. He promptly resigned and returned to Biafra as "a freelance journalist."

Among the Biafrans were more trained broadcasters than could be used by the stations. Some joined the fighting forces. Others visited refugee camps to cheer the homeless. Unemployed musicians and performers formed a Biafran version of a USO road show.

On the Owerri front, one rainy afternoon, soldiers of the Biafran Mongol and Destroyer Battalions waited in a muddy marketplace in an obscure village. Eventually, two old buses plowed through the mire into the square. A cheer went up as a troupe of entertainers climbed from the vehicle.

For the next hour, a first class band, several singers and a chorus line described by a Radio Biafra staffer as "mouthwatering," entertained the Ibo GIs. Then it was back to the buses and a jolting 10-mile ride to the next town.

The long-expected federal push on Umuahia came in April 1969. Several weeks of fierce fighting forced the Ojukwu government again to move its capital, this time to Orlu. On the 14th of the month, the Biafran stations moved for the third time. Several days later, though, they were back on the air from Obodoukwu, near Orlu. It was the last move.

Though the rest of 1969, things went from bad to worse. Nigerian forces drew the noose tighter around Orlu. As the new year came, it was clear the revolution was nearly over. On January 11, 1970, Ojukwu went into exile. The next day, at 7:30 a.m., Radio Biafra announced the senior military commander would have an important announcement later in the day. Except for a few news bulletins, Radio Biafra broadcast non-stop music—including, this author recalls, a moving program of well-known Black spirituals.

At 3:40 p.m., Maj. Gen. Philip Effiong announced the surrender of Biafra.

Still a few loyal technicians and chief announcer Okoko Ndem kept the station going unofficially until federal troops took it over two days later.

At 2:50 p.m., Jan. 14, 1970, Ndem went before the microphone to make the final announcement: "Henceforth, the callsign for this station will be Radio Nigeria, broadcasting from Obodoukwu in Orlu. The identification signal, until further notice, will remain the usual xylophone drums."

Then the announcer concluded with a few reassuring words for his family anxiously waiting in the city of Calabar.

The incredible story of an incredible radio station was over. Radio Biafra was dead! **PC**

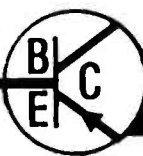

BUTTERNUT ELECTRONICS CO.

CB "BUTTERFLY"™ ANTENNA

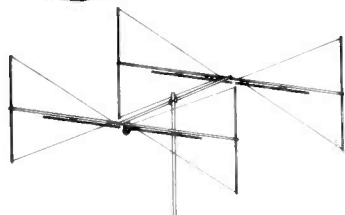

**YOUR NEIGHBOR
MIGHT THINK
IT'S A TV ANTENNA,
AND WHY NOT?**

The **BUTTERFLY™** is a low-profile CB beam which can be turned with a standard tv antenna rotator, making it ideal for the home, the weekend retreat, apartments, condos and other locations where an oversized beam could not be used. Assembly is quick and straightforward.

**BUTTERNUT INTRODUCES
SC-3000**

**A Scanner Antenna
for the "Pros"!**

Butternut's patented "trombone"™ phasing sections increase capture area and let you pull in the weak signals that aren't even there on conventional scanner antennas.

- Covers 30-512 MHz scanner ranges
- Height 11 ft.
- Omnidirectional coverage area
- UHF Up to 7 dB VHF Up to 3 dB



405 East Market • Lockhart, Texas 78644

Please send all reader inquiries directly.

CB Channel 9 Emergency Communications

Pressing A Mic Button Brings Instant Aid

BY JOCK ELLIOT

Citizen Band Channel 9, designated by the FCC for emergency use only, is a powerful and effective means of emergency communication. It is available, with no license requirement, to anyone for base or mobile operation. When there is a Ch. 9 network operating in an area, it can be a tremendous benefit to the community.

For example, if your car breaks down during rush hour in or around Albany, the capital of New York State, just sit there and chances are you will get help within minutes.

The reason: a group of everyday heroes who voluntarily man (and woman) Channel 9 and who get a big kick out of helping folks in trouble. They cover the emergency airwaves around Albany, Schenectady, and Troy, New York, and there are similar groups throughout the country. In some places, they are known as REACT networks; in our area, the network is called Tri-County Assistance.

During 1986, Tri-County logged more than 12,000 calls for assistance, ranging from people out of gas, to truck rollovers, to a bear (the berry eating type, not the kind with the radar) wandering around a suburb of Schenectady. These volunteers include:

- Hundreds of people driving to and from work.
- Dozens of home base stations operated by housewives caring for children, retirees, and people who work the nightshift. One volunteer is blind, and another in braces. Many have scanners by their sides to monitor police and fire calls.
- Scores of truckers travelling the interstate highways that cross near the capital of the Empire State.

Tri-County Assistance is a loose organization, with no by-laws, dues, or meetings, yet there are at least two hundred regular Tri-County volunteers on the air every week and another two or three hundred every month who are "just passing through." They have "handles" like "Bingo Queen," the "Air Brake Kid," or simply "Tri-County 61."

When a call for help comes in, or a mobile volunteer encounters an emergency situation on the road, the information is passed to a base station. The base station operator then phones the correct enforcement agen-

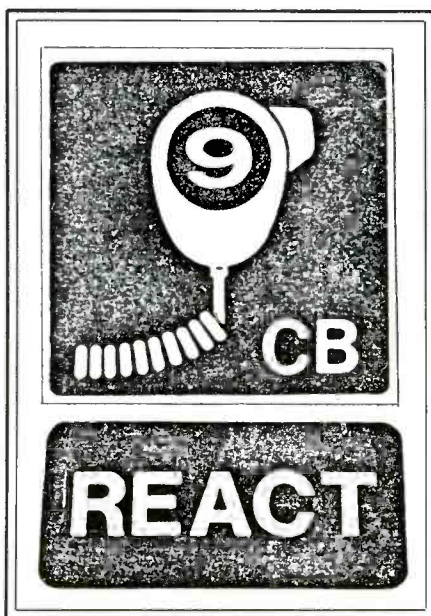

REACT's Channel 9 road signs let motorists know that help isn't too far away.

cy (police, fire department, state troopers) to handle the problem.

When it comes to disabled vehicles and other problems in traffic, the police are helped by the CVS Samaritans, a pair of breakdown assistance vans sponsored by a local pharmacy. The men who drive the Samaritan vans are expert mechanics as well as emergency medical technicians. They



Monitoring station dedicated to Channel 9 purposes.

have helped hundreds of motorists to get going again—at no charge—and many times they have been the first responders at the scene of an accident.

The information on problem situations is also passed to the Tri-County 44 base station manned by Ed Barnat. Several times a day, when he is not handling calls or phoning the troopers, he gives the road and traffic reports on WPTR radio, AM 1540, a 50,000-watt station.

Armed with the information supplied by the Tri-County volunteers, Ed signs on with the Roadwatch Report and so the information collected on Ch. 9 helps other commuters (even those without CB's) to stay out of trouble and traffic tie-ups by spotting the trouble spots for them.

Incidentally, Ed says the Tri-County Assistance Network is getting more calls now than at the height of the CB boom.

Some of the calls are quite bizarre. One morning there was a report of bedsprings in the high speed lane (the "hammer" lane, the truckers call it) of I-787. A few afternoons later, we had a report that a plastic "porta-john" at a construction site on the Dunn Memorial Bridge was on fire and in danger of melting down.

At other times, the situations are life-threatening. One night while returning from a class, my wife and I found one woman holding another at the railing of the Green Island Bridge. A car was stopped sideways across two lanes of traffic. We stopped, and the woman who was supporting the other said, "She has a note on her that says she is an epileptic and is suffering from heart failure."

We called for a base station on Ch. 9, and within minutes, ambulances, paramedics, and the police were on the scene. Without the CB, it would have taken us much longer to find a phone and call for help.

If you would like to be a part of the exciting action on Ch. 9, put a CB in your car or a base station in your home, and join your local REACT or Ch. 9 volunteer organization. If you simply want to hear the action, tune to 27,065 (AM) on your shortwave receiver. But make sure you have a good antenna. CB's operating on AM are supposed to transmit only 4 watts. **PC**

ICOM High-Band Modifications

One of the least expensive ways to obtain VHF high-band coverage is to modify an ICOM Amateur Radio 2 meter handheld. The ICOM 02AT series offers expanded frequency coverage between 143 MHz all the way through 165 MHz! The modification takes about an hour, and you end up with a powerful communications scanner/receiver for any VHF channel. This modification also leaves full transmit capabilities on the Amateur Radio 2 meter band, and also gives you emergency transmit capabilities throughout your newly acquired 143-165 MHz range.

WARNING: Even though you may possess a valid Amateur Radio license, it would be illegal to transmit on frequencies outside of your Ham radio 2 meter band limits. Even though you may possess a business radio or special emergency license for VHF operation, the modified ICOM 02AT does not meet FCC type acceptance, and could not be used for legal transmitting. However, in a real emergency, *anything* goes.

The Delicate Procedure

The modification procedure requires advanced skills in micro-circuit soldering. If you have never soldered tiny chips before, let someone else do this modification.

The only parts you will need are three silicon diodes, 1N914, 1N4148, or any equivalent. Radio Shack has them by the bundles. You might also pick up a 15-watt soldering iron plus some solder wick in case you make a mistake.

STEP A. Remove the battery, and unscrew four screws holding on the silver battery plate. Let the plate assembly and plastic battery lock tab fall clear. Remember how they come apart.

STEP B. Remove the back cover by unscrewing four long screws plus one small screw. Don't forget that one small screw—it is attached to the final amplifier and must be removed before opening up the back.

STEP C. Gently lift off the back, and then separate the front from the inside electronics. A ribbon cable interconnects the two, so be careful not to nick the cable.

STEP D. Looking down on the inside of the key pad, locate a sub-circuit board and remove it by unscrewing the two tiny, shiny, retaining screws and pulling back the silver retaining plate. This also is attached with a cable, and should be placed to the left of the handheld.

STEP E. Now locate the diode matrix external initialization pads at the very top of the exposed inside-front. Those little black

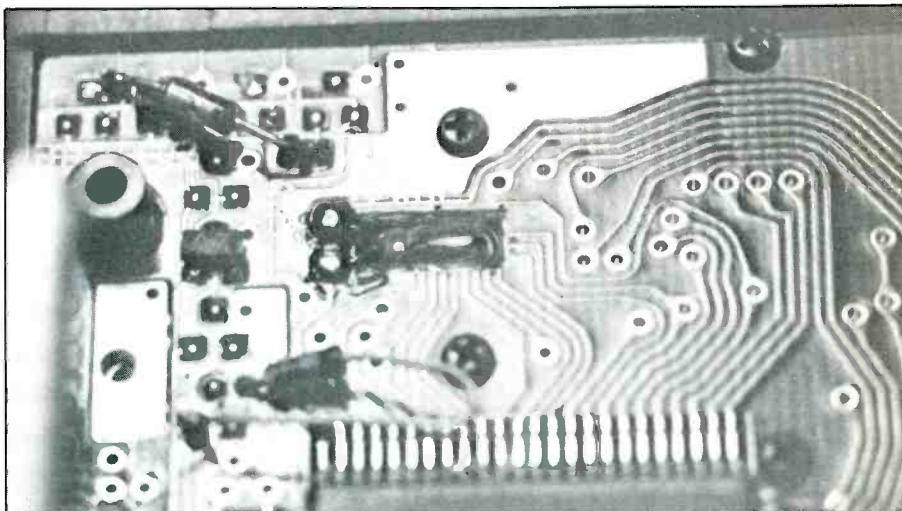

To modify an ICOM 02, add the diode as pictured in upper left corner.

things that look like ants are the diodes we will be working with and replacing.

STEP F. For ICOM 02AT's with serial numbers below 33,999, remove diodes D2 and D3 by unsoldering them or crushing them. For newer ICOM 02AT units, 34,000 and above, remove only diode D2.

STEP G. Now insert the diode(s) into the tiny holes at the top of the diode matrix. Insert the anode end, with the cathode sticking up. Look closely at the attached drawings and photos to make sure you get the di-

odes in the proper location. Use only one diode for newer sets, and three diodes for older sets.

STEP H. Solder the anode ends into place without overheating the diode or hole junctions. Then follow the drawing and photos to solder the cathode end into place. These pads are small, and delicate. This board costs over \$100 to be replaced by ICOM in case you foul it up, so be careful!

Now doublecheck your work. Make sure your external diode programming agrees

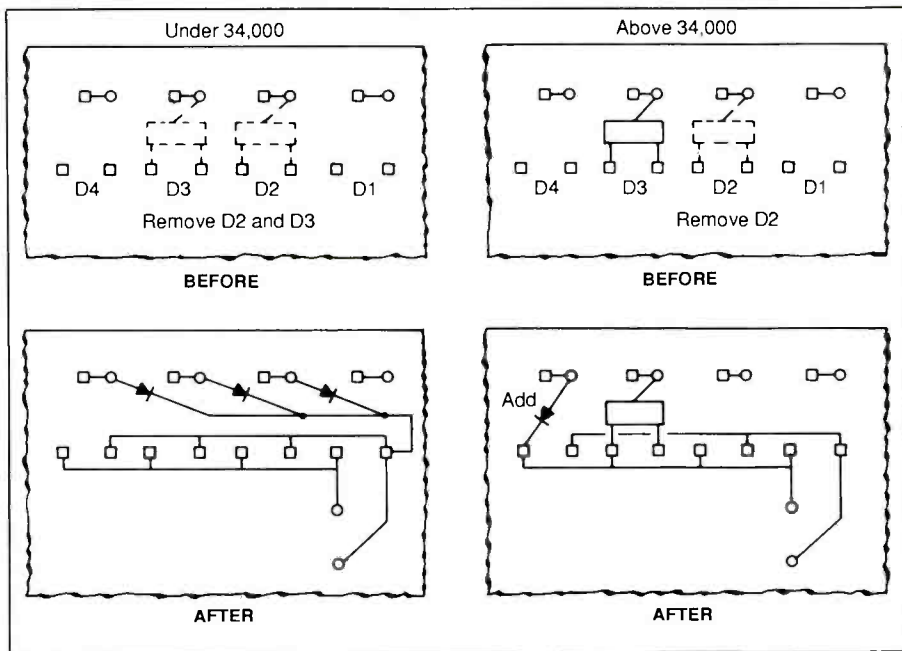

with the serial number set that you have. Also doublecheck that you have the right polarity on the diodes.

STEP I. Carefully replace the sub-circuit board assembly, and then reassemble the front cover onto the inside electronics. Now reassemble the battery place, but leave the back cover off for the next step.

STEP J. Turn your unit on, and the frequency display should be exactly where you left it. On some of the very older ICOMs, it may be necessary to reset the microprocessor. You then must "step" the unit back up to 146 MHz. If your frequency readout looks good, chances are you got the diodes in place properly.

Take a simple volt/ohm meter and clip the black lead to the handheld chassis ground. Set your scale on 1 volt and attach the red lead to R-253, a test point just below the shiny VCO can. It's the only resistor standing on end near the can with a bare lead.

STEP K. You now need to bring this off-scale voltage down to .5 volts by adjusting the coil L-218 in the VCO can. The coil is the lower access hole. Don't adjust the capacitor. Turn the coil counter-clockwise until your voltage reads about .5 volts near 146 MHz.

STEP L. Now let's check and see if we have unlocked the set. Key-enter the frequency 149.995 MHz. Step up to the 150 MHz band by pushing the "up" button. This advances the frequency electronically into 150 MHz. Now direct enter any 150 MHz

frequency, such as 155.160. If you can dial it in, your modification was a success. Now let's try the weather frequency. Dial in 159.995 MHz, hit the "up" button for 160 MHz, and then dial in 162.550 MHz or 162.400 MHz. If you adjusted the VCO properly, the weather channels should just barely lock in. If they do lock in, it is another verification that your modification was done correctly.

Before reassembling the back, you may wish to peak the receiver to favor either the 2 meter band where it already is, or somewhere near 155 MHz. Carefully adjust the three coils to the upper right of the VCO can for improved receiver sensitivity on a desired 150 MHz frequency. Make only a small adjustment—peaking the receiver at 150 MHz will decrease performance at 146 MHz, the Ham band.

WARNING: Do not attempt to transmit out of band. This set is not type-accepted. It will work, but should only be operated out of band on transmit in an emergency. Also, it may be illegal to tune into certain communications covered by the Electronic Communications Privacy Act.

Reassemble the cover, memorize those out-of-band frequencies for instant recall, and enjoy your new capabilities with any ICOM 02AT 2 meter handheld transceiver.

REPEAT: This modification should only be undertaken by those with advanced soldering skills and the dexterity of a pygmy when dealing with these tiny circuit diodes and pads. **PC**

Attention Amateur & CB Radio Operators!

If you want an antenna to give you the Best in Performance & Quality, SAVE WASTED TIME and MONEY —

INVEST IN A JO GUNN



Jo Gunn Enterprises

Route 1 — Box 383
Ethelsville, AL 35461
(205) 658-2229

Call or Send \$2.00 for Complete Catalog and Pricing of Antennas. (\$2.00 Refundable on 1st Order.)

Office Hours
10:00 a.m. to 6:00 p.m. (CST)
DEALER INQUIRIES, PLEASE CALL

Copy Worldwide Short-wave Radio Signals on Your Computer

Remember the fun of tuning in all those foreign broadcast stations on the short-wave radio? Remember those mysterious sounding coded tone signals that baffled you? Well, most of those beeps & squeals are really digital data transmissions using radioteletype or Morse code. The signals are coming in from weather stations, news services, ships & ham radio operators all over the world. Our short-wave listener cartridge, the "SWL", will bring that data from your radio right to the video screen. You'll see the actual text as it's being sent from those far away transmitters.

The "SWL" contains the program in ROM as well as radio interface circuit to copy

Morse code and all speeds/shifts of radioteletype. It comes with a cable to connect to your radio's speaker/earphone jack, demo cassette, and an excellent manual that contains a wealth of information on how to get the most out of short-wave digital DXing, even if you're brand new at it.

For about the price of another "Pac-Zapper" game, you can tie your Commodore 64, 128 or VIC-20 into the exciting world of digital communications with the Microlog SWL. \$64. Postpaid, U.S. MICROLOG CORPORATION, 18713 Mooney Drive, Gaithersburg, Maryland 20879. Telephone: 301 258-8400.

MICROLOG
INNOVATORS IN DIGITAL COMMUNICATION

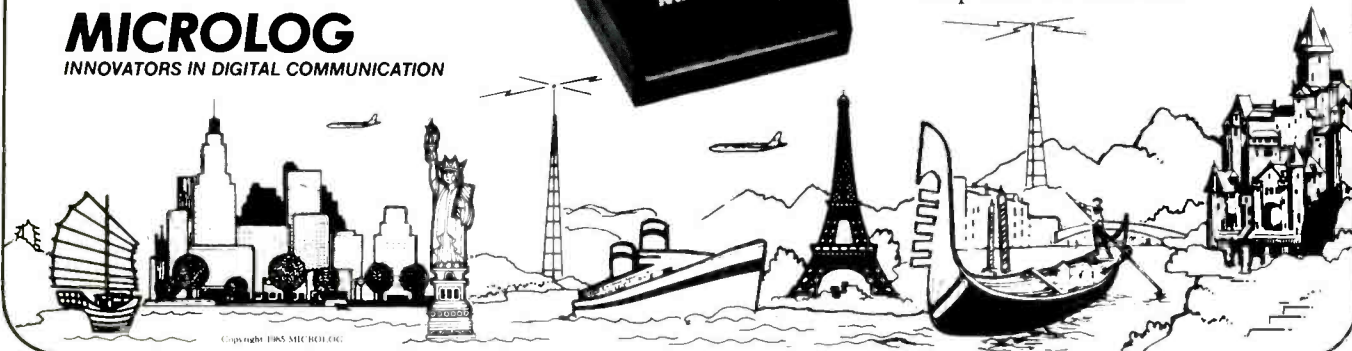
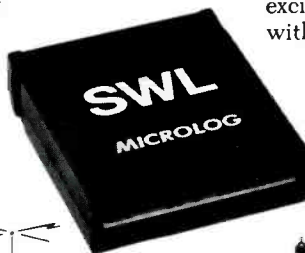

CIRCLE 115 ON READER SERVICE CARD

INSIDE THE WORLD OF SATELLITE COMMUNICATIONS

NASA'S New X-1

NASA's Marshall Space Flight Center is developing a new near-space (high-altitude) long-endurance observational platform. The platform is an ultra-light, unmanned aircraft with a wing span of up to 360 feet. NASA's prototype, the X-1, is constructed of high tech alloys similar to the alloys used to build the Voyager. As you will recall, the Voyager was the first aircraft to fly non-stop around the world without refueling.

The X-1 is NASA's answer to the Department of Energy's (DOE) request for an economical scientific research platform. The aircraft and its proposed ground support system is known as the CO-OPS project. CO-OPS is derived from the platform's intended purpose as a **C**arbon-dioxide **O**bservational **P**latform **S**ystem.

According to Dr. J. Briscoe Stephens, CO-OPS Project Scientist at NASA's Marshall Space Flight Center, "the concept of a long-endurance platform was initially developed by NASA's Langley Research Center in the 1960's, but the project was not going as planned. By the time enough solar panels were added to keep the plane aloft for extended periods of time, it had neither the room or the lift capacity left to carry the original payloads." Another source of power and lighter building materials would have to be developed before the system would prove practical.

Then, during the oil crunch of the early 1970's, NASA, at the request of the DOE, began a solar power project. The purpose of the project was to find a way to use solar power to supply some of the country's energy needs. Marshall Space Flight Center decided the best way would be to send a high-altitude platform aloft, equipped with solar panels, to collect the more intense radiation from the Sun at high altitudes. They discovered that this collected energy could efficiently be converted into microwave RF and beamed down to waiting ground stations for conversion into electricity for home use. Though this project was never implemented, the DOE again turned to NASA in 1980.

Concerned with the dangerous effects of the depletion of the ozone layer by man-made chemicals which are routinely released into the atmosphere, DOE began a thorough study. The ozone layer is a thin layer of atmosphere at high altitudes that protects us from the dangerous radiation of the Sun. Several systems were already in place for NASA and DOE to use for such studies: Airships (blimps), satellites, rocket

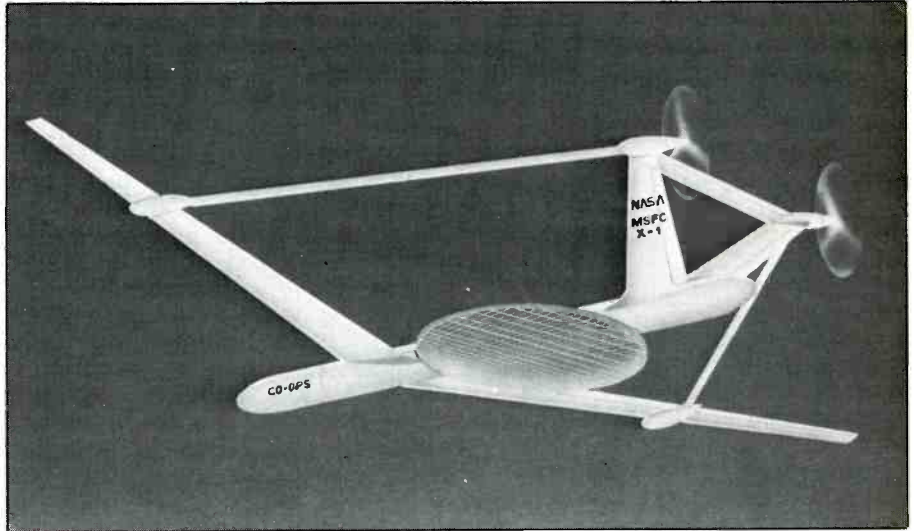

NASA's new X-1 prototype.

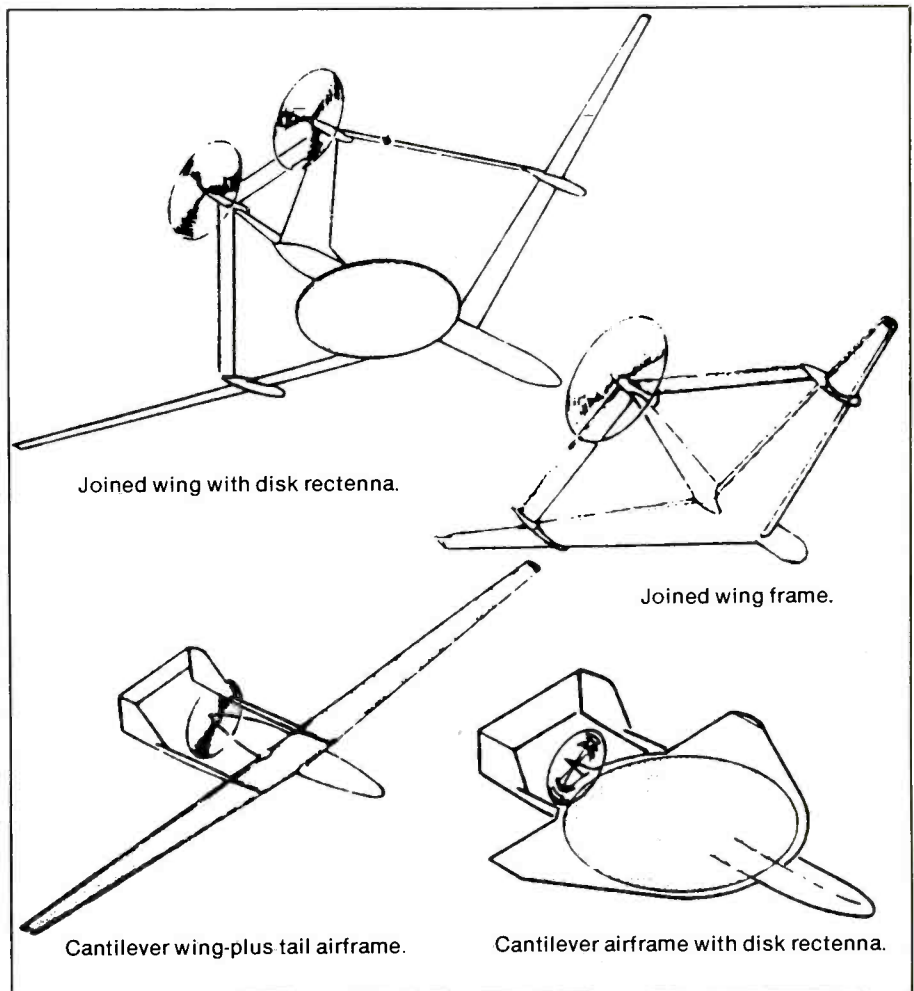

Possible configurations for CO-OPS aircraft.

probes, radiosondes (weather balloons), and the U-2 aircraft. Each of these systems have their limits and none are cost effective. The U-2, for example, costs just over \$8,000 an hour to operate. The CO-OPS system will easily be the least expensive method of conducting the studies.

The X-1's power requirements will be met by simply reversing the microwave transfer system developed by Marshall in the 1970's. Microwave energy will be transmitted to the aircraft while in flight. It will power the engines and all onboard systems. Dr. Stephens describes the microwave system: "We will use somewhere over 3,000 microwave magnetrons (microwave oven type transmitters) to generate a low density beam of energy on 2.45 GHz. It will be directed at the aircraft's antenna from ground stations. It is then a relatively simple matter to convert the microwave to direct current." The antenna mounted on the underside of the X-1 is called a rectenna as it has the ability to rectify the microwave into DC as it is received from ground stations. This rectenna can also be built into the surface area of the wings and underside of the aircraft to improve aerodynamics.

The CO-OPS platforms are designed to fly a circular, geo-stationary pattern at an altitude of up to 121,000 feet. They are capable of carrying 1,500 lbs. of scientific and military equipment for up to three months at speeds of 120 mph. The X-1 is launched like a glider; it is towed aloft by another aircraft.

Science

NASA's version of the X-1, and those supplied to the DOE, will carry a wide range of scientific equipment: imaging sensors, high resolution infrared radiation sounders, spectroradiometers and scanning multi-channel radiometers. These will be used to compile profiles of temperature, water, soil moisture content, cloud formation and high altitude winds. Gas, aerosol and particle samples will also be carried aloft on the DOE CO-OPS.

CO-OPS project scientist, Dr. Stephens, believes that the Defense Department will and is making use of the X-1 technology in the Strategic Defense Initiative. At DOD the platforms are known as Airborn Optical Surveillance platforms (AOS). The platform could be the last point of defense against incoming missiles. It can spot them 450 miles down range using infrared sensors and would be most useful against Soviet submarine launched missiles. It would only take six minutes for these warheads to reach U.S. targets. The platform could give us the maximum time to respond to such a threat. It could be used to relay energy from laser beam weapons, target incoming missiles or coordinate ASAT (anti-satellite) systems. They can carry much of the same equipment that reconnaissance satellites carry and they could be used in Electronic Countermeasures. CO-OPS will also be able to be cross-linked with other satellites and aircraft

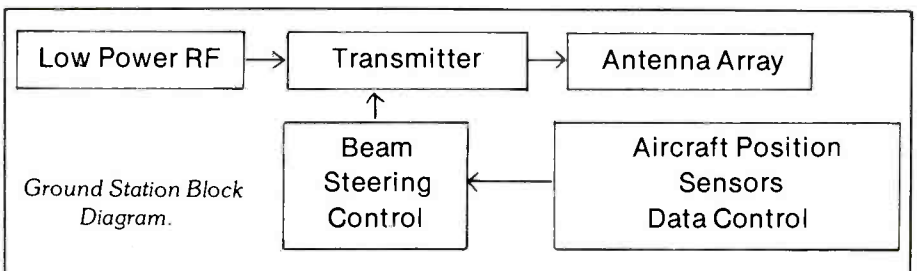
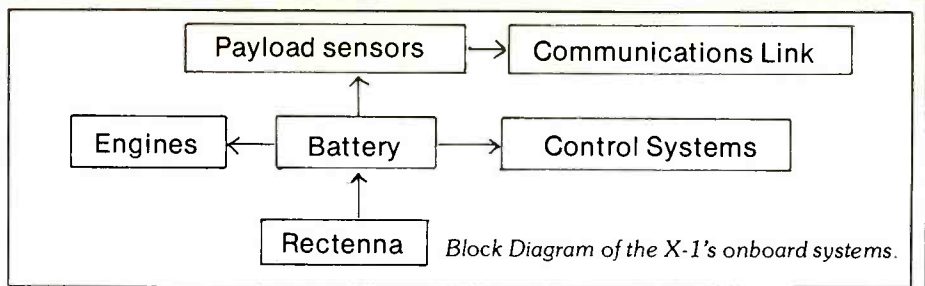

communications systems. They can be designed to serve as a platform for viewing deep space or tracking satellites.

Lockheed is likely to be the builder of the CO-OPS system. They claim to be able to have the first CO-OPS operational by 1990. A more realistic target date might be 1995 considering the usual time and cost overruns on the standard government contract. The first stations, consisting of a CO-OPS platform, transmitter, antenna array and airfield will cost \$35 million. Each of the next four stations should cost considerably less. NASA recommends that DOE CO-OPS stations be constructed in the following locations: Marshall Space Flight Center in Huntsville, Alabama; Vandenberg AFB, California; and unspecified locations in the Antarctic, Panama (Central America) and New Jersey.

The transmitter site for the CO-OPS will require a 350-foot diameter piece of flat real estate for erecting the antenna array. The antenna will be a slotted array consisting of 3,025 magnetrons on a 200-foot square panel supported by 30 pedestals. Each of the 3,025 magnetrons will generate 500 watts of RF which will be beamed at the X-1 in a circular pattern 120 feet across. The data collected by the onboard equipment will be sent by radio to NASA or DOE facilities via satellite or other communications links for analysis.

Conclusions

While high technology presents many challenges, becoming technology-dependent can cause problems. Dr. Stephens thinks the greatest challenge to the CO-OPS program is not unlike that facing the SDI program: data management. This problem is one with which the Jet Propulsion Laboratory (JPL) is familiar. They are responsible for the data flow from our deep space probes. Even with computers running non-stop, JPL will be busy for decades studying the information our deep space probes have

Development Cost Estimates

Platform	Cost
CO-OPS	\$35 million
Airships (balloons)	\$90 million
Geo-Stationary Satellites	\$500 million
U-2/ER-2 Aircraft	\$70 million
Low Orbit Satellites	\$115 million

generated, but with the new super computer chips now being developed and appropriate software, each of these systems should be manageable by the time they became operational.

CO-OPS have a wide range of military and commercial applications. They can provide realtime-TV of any target. Shipping lanes can be monitored by the Department of Transportation or Coast Guard. Forests and woodlands can be monitored visually for fire protection. The FBI could have some very interesting duties for such an aircraft. Even local law enforcement and governmental agencies could monitor traffic flow on our streets.

Commercial interest will find the CO-OPS an economical way to provide regional communication relays for TV, radio, telephone and data links. They could even carry Amateur Radio transponders. It looks like another NASA project will be providing spin-offs to the general public. ("Spin-off" is the NASA term for benefits the general public receives from their research, for example, Velcro.) In this case they will be providing communications services for the U.S. telecommunications industry and a whole new area of monitoring for the scanner operator and SWL.

All comments, questions and suggestions should be addressed to *Satellite View*, in care of POP'COMM. Be sure to include an SASE. See you next month.

PC

ANTENNAS AND SIGNAL IMPROVING ACCESSORIES

The Testing Of A Delta Loop Antenna

The magnitude and quickness of propagation change is so great in the HF spectrum that antenna performance evaluation by replacing one antenna with another does not disclose the whole story. It might be valid at times when one antenna is really a loser. In the time it takes to put one down and the other up the signals can drop from strong to barely readable, especially from a long distance station.

What the DX'er wishes to know is just how well an antenna responds to a weak signal in such a manner that an ID can be made while with another antenna it might not be possible. Also, if you are an avid program listener, especially a music fan, you prefer the reception be solid and that the signal hold at reasonably constant level despite fading. Fading, of course, can't be eliminated but if you can deliver a strong signal to the receiver the receiver circuits themselves help to maintain a more constant reproduction.

Selective fading causes the audio to distort when the frequencies which comprise the two sideband spectra of an AM signal fade relative to each other. The ultimate solution to this problem is to make the changeover from AM modulation to single sideband (SSB) in International Broadcasting. Such a change is long overdue and might well be holding up the wide acceptance of international broadcast listening. As a stop-gap procedure and if your receiver has sideband capability, switch it on sideband and learn to tune it properly to demodulate just one of the sidebands. This helps improve clarity although it is not nearly as satisfactory as all-out sideband broadcasting could be. Antennas cannot solve selective fading distortion although it does become a little less objectionable when the incoming signal is as strong as possible.

Antennas can be best compared by erect-

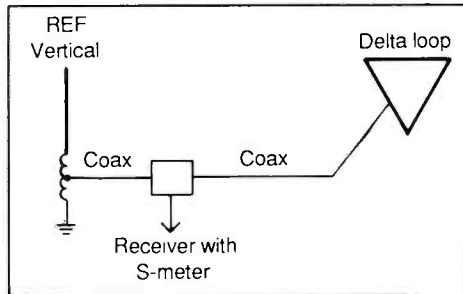

Figure 1: Test set-up.

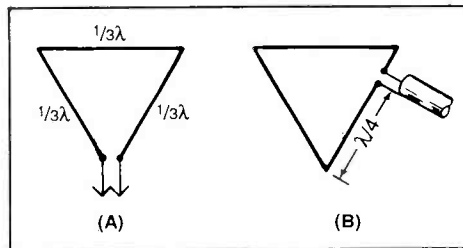

Figure 2: Basic (A) and modified delta loop (B).

ing both and switching quickly between them. Watch your S-meter. Isolate antennas as best you can and use coaxial lines to a coaxial switch. Interaction between antennas is not as severe as one would expect even when they are quite near to each other. Results balance out rather smoothly when you check often and on many stations. Single-wire fed antennas are more troublesome and you must keep the incoming signal lead-ins separated as much as is practical.

A second way of checking out an antenna is to compare it with a reference antenna, the performance of which is well known to you. Such is the case at our location. Our reference antenna is the vertical described in

the January and March '87 columns. Additional loading coil construction detail was also presented in the April '87 issue. The basic vertical serves as a reference on the 16 through 25 meter bands. Along with the tapped loading coil it also serves as a reference on bands 31 through 120 meters. On these latter bands a proper tap selection must be made to obtain resonance on a specific band.

Only a 20' coaxial line links the reference antenna to the operating position and one input of a two-position coaxial switch, Fig. 1. There is good isolation from the tested antenna with this arrangement and the influence of a longer length of line to the tested antenna is duly noted and only of significance at very high frequencies. In itself the reference is a good antenna. Any antenna that equals or surpasses its results on any one band is a good performer on that band.

The Delta Loop

In our tests a 31M delta loop was checked out against the reference. First the reference was resonated on the test band. Next the delta loop was erected and resonated on about the same frequency using an antenna meter. The coaxial line was attached and connected to the other input of the fast changeover coaxial switch.

The delta loop is a full wavelength antenna and on bands 31M and higher the actual overall length of the wire in feet can be determined by dividing the frequency in MHz into the constant 984. The length of the wire cut was 102' (approximately 984/9.7).

Theoretically, the three sides of the delta should be of equal length, Fig. 2A. In practice, though, it is usually necessary to make the top longer than the sides in erecting such an antenna for low frequency use. Within reason there is little change in results.

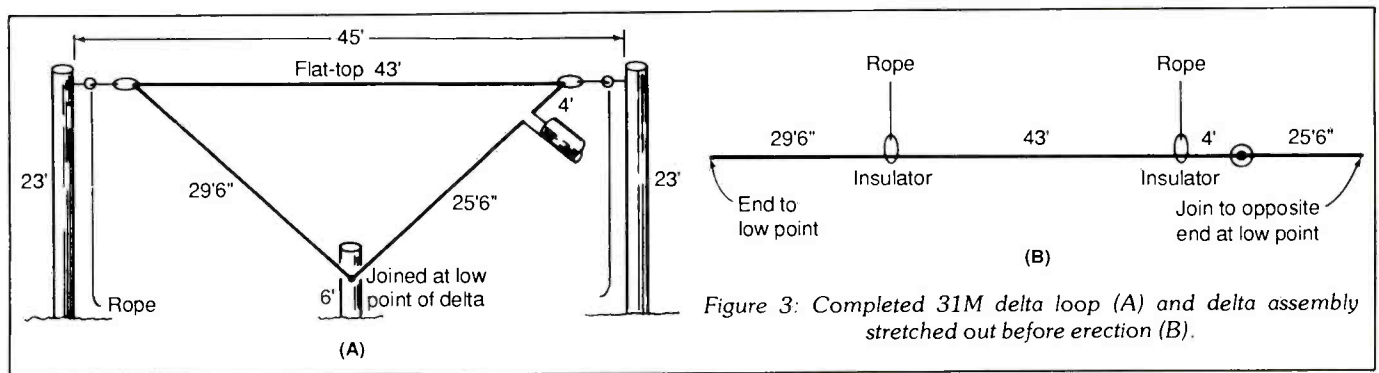

Figure 3: Completed 31M delta loop (A) and delta assembly stretched out before erection (B).

Table 1

Test results in each of four quadrants

NE Quadrant

Country	kHz	Angle	S*
Norway	9590	38	+1
Czech.	9630	47	+2 1/2
Hungary	9835	48	+2
DW	9640	49	+2
UK	9915	50	+2 1/2
Canada	9625	51	+1
Israel	9435	53	+1
Egypt	9655	56	3
Spain	9630	65	+3
Algeria	9640	66	+1

SE Quadrant

Gabon	9790	93	+3
RSA	9615	103	+3
Fr. Guiana	9800	143	+3
Brazil	9635	149	+3
Bonaire	9590	165	+1
Ecuador	9870	184	+1

SW Quadrant

Country	kHz	Angle	S
Cuba	9770	201	+1
Guatemala	9940	211	+1 1/2
WRNO	9852.5	234	+3
N. Zealand	9620	244	+3
Australia (Shepparton)	9580	260	+4

NW Quadrant

WHRI (Indiana)	9770	280	+3 1/2
KGEI	9680	281	+3
VOA	9540	283	+2 1/2
Australia (Perth)	9610	310	+2
Australia (Carnarvon)	9770	331	+1
China	9535	350	+1

*S = S-units above reference vertical.

In our modification the point of attachment of the coaxial line was one-quarter wavelength above the low point of the delta, Fig. 2B. This connection lowers the wave angle and improves long range operation. It is a popular style of antenna for Ham radio operation on 40 meters in Europe; data was sent to me by friend Paul I2POR in Italy from the newsletter of his local Ham club.

In our installation the dimensions and arrangement of Fig. 3A were used. The flat top portion of the loop was erected 23' above ground matching the height of the reference vertical. The flat top span was 43' and supported by two PVC masts that were separated by 45'. The bottom of the loop wire was several feet above ground.

First the antenna was stretched out linearly as in Fig. 3B. The two insulators were located properly and wire was looped tightly in position using tape as in Fig. 4. The di-

Coming Soon In

POPULAR COMMUNICATIONS



- The Loran Story
- Peruvian Pursuits
- We Review The EEB 2020
- Police Communications
- Design VHF Covert Antennas



NEW FROM VIENNA!



THE ELECTRONIC EQUIPMENT BANK OF VIENNA, VIRGINIA, IS PLEASED TO ANNOUNCE THE ADDITION OF TWO NEW RECEIVERS TO ITS GROWING FAMILY OF SHORTWAVE RADIOS. NOW WITH CLASSIC EUROPEAN STYLING AND UNCOMMON ATTENTION TO DETAIL. THE NEW GRUNDIG SATELLIT 650 AND SATELLIT 400 SWL RECEIVERS!

GRUNDIG®



Satellit 650



Satellit 400

The Satellit 650 International is the Ultimate in German crafted Portable radios. Along with excellent Audio performance the Satellit 650 also has these fine features: • AM, SSB, CW and FM. • Covers 510—1620 KHz, 1.6—30 MHz AM and 87.5 to 108 MHz FM. • Direct keyboard frequency entry. • PLL Quartz Crystal Synthesized for precise tuning and stability. • 60 Programmable memories (16 FM, 8 MW, 4 LW & 32 SW) • Up to 30 Watts peak audio output power. • Built in Ferrite and Telescopic Antennas. • Dual speaker/switchable. • World Power: 110-127/220-240V 50/60 Hz. • DC power with batteries (not provided) or you can use Nicad Batteries (optional/can be recharged while the radio is playing in the AC position!). • Dimensions 19 3/4" x 9 1/2" x 8". • Weight 19 lbs.

Manufacturers List \$1149.00 EEB Introductory Price \$995.00 + \$12 UPS

SATELLIT 400

The Satellit 400, with its rounded corners and smooth lines is the obvious "style leader" in personal portables. Beautifully crafted, this small portable covers all Shortwave bands plus MW and FM. It's unexcelled audio will surprise you! • Direct keyboard frequency entry. • 24 Programmable memories. • Scanning. • 2 Clocks (turn on/turn off). • World power 120/240 V 50/60Hz. • Battery powered (not supplied) and optional Nicad Batteries (nicads can be recharged while radio is playing in AC mode). • Dimensions 12" x 7" x 3" • Weight 5 Lbs.

Manufacturers List \$449.95 EEB Introductory Price \$399.95 + \$6.00 UPS



ELECTRONIC EQUIPMENT BANK
516 MILL STREET, N.E.
VIENNA, VIRGINIA 22180
TELEPHONE (703) 938-3350
ORDER TOLL FREE: 800-368-3270



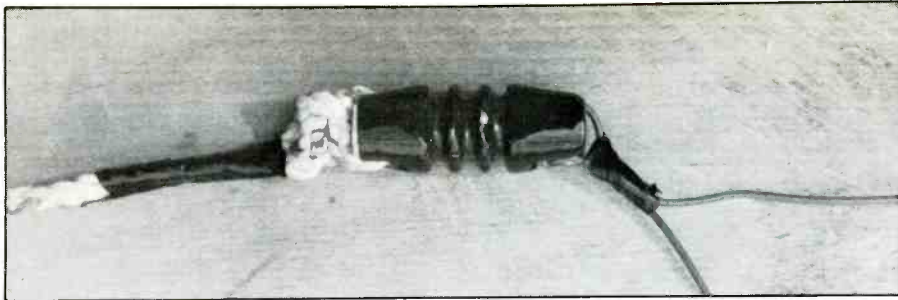

Figure 4: Arrangement at each top corner of delta loop.

pole-to-coaxial line connector was placed at its proper position. A 20' length of coaxial line was attached. The individual ropes attached to the insulators are used to hoist the flat-top wire ends to the top of the mast, Fig. 5. The two wire ends were then walked over to the center short mast. The wire ends were bared and they were then spliced and, finally, taped to the short PVC pipe.

Next the antenna meter was connected to the coaxial line to check the resonant frequency of the line. Actually, it is wise to add about 2' of extra line to the very ends of the made-up antenna. If the resonant frequency is too low after erection, it is a simple matter to clip off equal pieces at each end to raise the resonant frequency to the desired MHz.

The results of the test are summarized in Table 1. Listings are given in order of receiving angles at this site. A number of them are

displayed in the bearing circle of Fig. 6.

31 meters is a good test band for checking out basic types of antenna because reliable SWB signals are available from any directions and distances. The ability to check out an antenna in a variety of compass angles gives you some clue about the directivity of an antenna. The angles given apply specifically to my location in southeastern Pennsylvania. Note that the maximum sensitivities are displayed in a very approximate E/W line. The line of the flat top portion of the delta loop was 65°/245°. The readings indicate the broad broadside directivity of the delta loop, with minimums North and South.

The full wave delta loop was very effective in this our first application of the loop as an SWB receiving antenna. We anticipate additional arrangements and tests with a

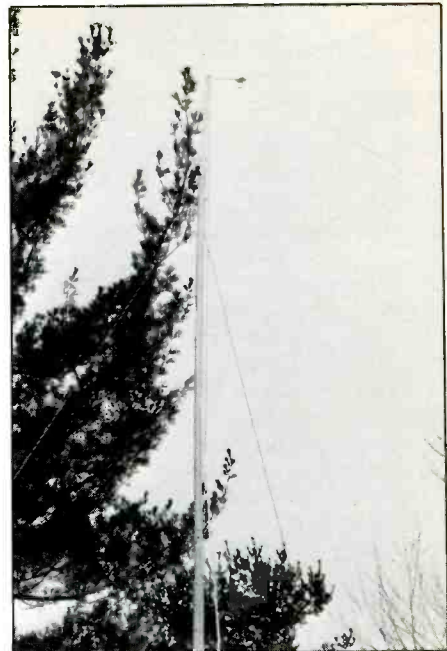

Figure 5: One mast of delta loop assembly showing rope that pulls up one corner.

hope of improving its bandwidth to better accommodate other bands. There are some ideas to be tried. More later. Operation, though, is quite acceptable on a number of other bands using the dimensions given. **PC**

antennas

The Best of Both Worlds

High Gain 7 dB UHF

TROMBONE

Wide Band To 1300 MHz

DISCONE

D130 79.95

SC3000 57.95

Diamond and/or Butternut

Buy Both-Get a Switch FREE!

Cable & Connectors To Order

1-800-HAM 0073

H. C. Van Valkenburgh Co.

1140 Hickory Trail

Downers Grove, IL 60515

Satisfaction Guaranteed

VISA MasterCard

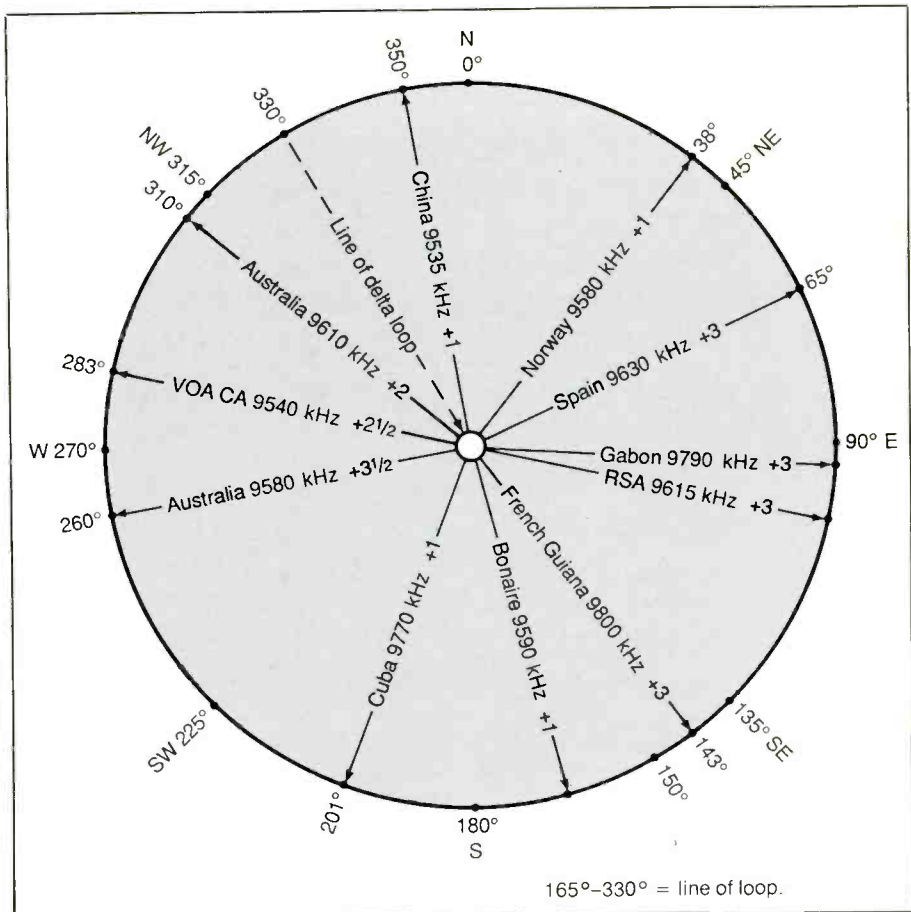

Figure 6: Receiving angles for various test signals picked up at receiving site.

Two Dispatchers Aid In Lifesaving Effort

When someone needs help, they call 911 in many parts of the country and the appropriate police, fire or ambulance personnel are dispatched to the scene within minutes. But sometimes even those few minutes are too long.

Every minute counted one night in West Point, California when 67-year-old James Pahel collapsed unconscious in the family kitchen. Pahel's wife, Wanetta, called Calaveras County 911 dispatchers. According to an account of the incident in *The Stockton Record*, two dispatchers, Sue Miller and Cheri Hawks, aided greatly in saving Pahel's life.



Calaveras County, California, dispatchers Sue Miller (left) and Cheri Hawks (right) helped Wanetta Pahel save the life of her husband James.

SCAN PUBLIC SERVICE AWARD

While Hawks dispatched volunteer medics and an ambulance crew to the Pahel home, Miller told Wanetta how to perform cardiopulmonary resuscitation (CPR) over the telephone.

"Okay, see if you can find a pulse," Miller told Pahel. (The conversation was automatically taped.) "Put your hand under his neck, and tilt his head back."

"I can't do this all my myself," Pahel replied, according to the *Stockton Record* account.

"You're going to have to try and help us help him, okay?" Miller said. "Is he laying down flat? Put your hand under his neck and pull up on it. Put the other hand on his

forehead and pinch his nose. Now, breath four times real hard."

There were no sounds on the tape for about 20 seconds while Pahel tried the procedure described by Miller. In the background of the tape recording, the sound of Hawks dispatching medical crews can be heard.

Then Wanetta Pahel returned to the phone. "I got him. He's breathing."

"Great. Keep him calm. We're going to send an ambulance right away," Miller told Pahel.

When the medics arrived at the Pahel house, Wanetta said that she had simply followed the instructions given to her over the telephone.

"We were just doing our jobs—saving lives," Hawks told the *Record*.

But Wanetta believes that both Miller and Hawks did considerably more. "Those first few minutes were crucial," she asserted. "My husband wouldn't have lived if the dispatcher hadn't helped me out."

Gail Spann, a member of the ambulance crew that arrived at the Pahel home, also lauded the effort of the dispatchers. "It's fantastic those dispatchers have the training to give us a salvageable person to work with once we get there," she said.

Even though they played such a vital role in Pahel's resuscitation, the two dispatchers didn't brag about it. In fact, they didn't tell anyone what happened. Ambulance crews that took part in the rescue told sheriff Fred Garrison about the incident the following day.

Ward Redman, deputy at the Calaveras Communications Center, said that this type of story probably happens frequently, but dispatchers apparently don't make a big deal about it. Redman said that this was the first such lifesaving case this year. Last year, according to Redman, the dispatch center helped save about a dozen people.

Dispatchers are trained in first aid, and use medical cards at the dispatch console for such an emergency. Miller worked from memory on this call.

For their contribution to a successful lifesaving effort, dispatchers Sue Miller and Cheri Hawks will receive the SCAN Public Service Award. The award consists of a special commendation plaque and a \$100 cash prize. For making the nomination, Laverne Visser of Stockton will also receive a commendation plaque. Congratulations to all of you.

Best Equipped

Don Boyer of Kutztown, Pennsylvania, is primarily interested in military communications in the HF and VHF/UHF bands.

Don uses a Bearcat 300 scanner with a Grove "Scanverter," ICOM IC-R71A and ICOM R-7000. A Regency HX-1200 programmable handheld scanner is used to take along to airshows.

A licensed Amateur (WA3CUQ), Don also uses a Yaesu FT-757GX transceiver for Amateur Radio contacts and for monitoring as a general coverage receiver. A Kenwood TS-830S transceiver driving a Heath SB-



SCAN PHOTO CONTEST WINNERS

200 linear amplifier is also used on the Amateur bands.

Antennas used for this equipment include the MFJ-1024 active antenna for 3-30 MHz, a TET Discone antenna that covers 80-480 MHz, and an aircraft UHF antenna that is mounted in the attic.

A Commodore 64 computer with an AEA CP-1 interface is used to monitor RTTY communications, along with a Commodore 1541 disc drive and Epson LX-86 printer.

Don writes that he is wiring an audio patch panel so he can connect the audio output of any station receiver to a tape deck.

Best Appearing

Christopher Anolin of Windsor, Ontario,



Canada, writes that he has always had an interest in electronics, but only entered the scanning hobby three years ago with the purchase of a Bearcat 200 scanner.

Since that time, Christopher has added many other pieces of equipment. In this six-foot desk setup he has a Bearcat 100 scanner, Midland 79-911A CB, National Panasonic RF-788 shortwave receiver, cordless phone, two-line telephone controller, telephone answering machine and Sony Walkman. And, of course, the computer equip-

(Continued on page 76)



SHORTWAVE HEADQUARTERS

Our 17th Year! Order Toll Free 800-368-3270
EEB—The Nation's Leading SWL Supplier



SMALL PORTABLES

DIPLOMAT 4950

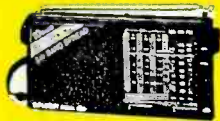

\$99.95 VALUE
INTRODUCTORY
PRICE
\$69.95

The perfect radio for the person on the go!

- Medium wave AM 550-1670 kHz.
- FM 88 to 108 with stereo head set out.
- Shortwave 2.3 to 5 MHz continuous 120, 90, 75 and 60 meter bands (not covered by Sony ICF 4910) and 49, 41, 31, 25, 19, 16 and 13 meter band each expanded for easy tuning.

"AC Adapter Optional \$9.95 (SPA4.5)"

SONY ICF-4910



\$99.95
+ \$4.00 UPS
LIST \$129.95!

- FM & AM
- Seven Short Wave Bands!
- FREE earphone, carrying case & shortwave guide.
- OPTIONAL AC Adapter AC-39 \$14.94

SANGEAN ATS-801



ONLY \$99.95
+ \$4.00 UPS
LIST \$199.95

- SW 5.8-15.5 MHz FM 88-108 MHz
- LW 155-281 MW530-1620 kHz
- 25 Program Memories
- Digital Frequency & Clock Readout
- Manual or Autotone
- Same Weight and Size as SONY ICF 2002
- Free 100 Page SWL Book

Optional A.C. Adapter SPA-6 \$9.95

DXers Dream TOSHIBA RP-F11

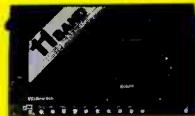

- Covers all International & Tropical Bands
- S Meter, Safety Off Lock

SAVE \$40.00 SALE \$79.95

"One of the finest receivers available under \$130.00"

List \$129.95

Optional AC wall adapter TAC 64 \$11.95

SONY ICF 2002

- Ultimate compact HiTech at an affordable price
- 25% size of famous SONY ICF 2001, SONY's best seller
- 150 kHz - 30 MHz
- AM, FM
- Memories
- Keyboard entry
- Scan
- 24 hour clock



Sale Price \$239.95

A.C. Adapter SPA6...\$9.95

DATA BASE INTERNATIONAL 1987 Edition

- Up-to-date Picture of SW Broadcasting.
- Frequency by Frequency, Hour by Hour.
- Station Name, Location, Frequency, Time, Language, Target Area, Power.
- Innovative Computer Display. Makes Easy Reading of Complex Information.
- In-depth Equipment Review.



NOW while supplies last \$9.95 + shipping.

LARGER PORTABLES

EEB 2020

NEWEST HIGH TECH RECEIVER

\$299.95 VALUE
INTRODUCTORY
PRICED
\$199.95



FREE
AC Adapter &
Radio Stand
Mention this AD
(\$24.90 value)

- High stability for good CW-SSB-RTTY reception.
- AM button allows full coverage of 150 kHz to 30 MHz.
- FM button allows full coverage of 88-108 MHz.
- Multimode AM-FM-CW-SSB allow full coverage of commercial traffic, Amateur, aircraft, ship at sea, & more!
- 9 programmable memories.
- Same size & weight as SONY ICF 2010.

FREE ONE YEAR WARRANTY!

SONY ICF 2010

FREE RADIO STAND
(\$9.95 value)

- 150 kHz to 30 MHz, AM, CW, SSB
- 76 MHz to 108 MHz FM
- 116 MHz to 136 MHz AM Air Band
- 32 Programmable Memories
- 4 Event Timer
- Synchronous Detector
- Wide/Narrow Bandwidth



IN STOCK!

"This is one of the finest receivers available today under \$500."

A.C. Adapter Included **Sale Price \$329.95**

DESK TOP RADIOS

R-2000 KENWOOD



Kenwood offers a communication receiver to suit your listening pleasure. It covers the full spectrum: Long, Medium, and Shortwave. AM-CW-SSB-FM Wide-Narrow Selectivity, Noise Blanker, and more.

R-2000 Special Sale **\$499.95**
VHF Converter (VC-10) **\$149.95**

YAESU FRG-8800

\$619.95
+ \$8.00 UPS
**150 KHZ-
30 MHz**



- CAT computer compatible
- 12 memories—scan—RIT
- Keyboard frequency entry
- Dual 24 hour clock timer recorder control
- Optional FRV8800 VHF converter 118-174 MHz \$119
- All mode AM-SSB-CW-FM
- Green LCD display
- 150 KHz to 30 MHz

KENWOOD R-5000



Computer control is here!
IBM only, disk & documentation
\$49.95. + \$4.00 UPS
Kenwood Interface IC232C, IC10,
AC10 ONLY \$114.95 + \$5.00 UPS
**PACKAGE DEAL: Disk & Interface
\$149.95 + \$4.00 UPS**

All-Band All-Mode Receiver Covers 100 kHz-30 MHz (108-174 MHz with VC-20 option)

- 100 Memory Channels
- Direct Keyboard Frequency Entry
- Programmable Scanning (Center-Stop Tuning)
- Computer Control Option
- Built-In Power Supply
- Many More Options Available.

Special Introductory Price...\$749.95
VC-20 Option...\$169.95

Service manual
order: SMR5000
price: \$20.00

DESK TOP CONT.

ICOM R71A

Only \$799
+ \$8.00 UPS



- 100 kHz to 30 MHz • Keyboard entry
- 32 programmable memories • SSB-CW-AM-RTTY (FM optional) • Wide dynamic range
- Digital PLL • Memory scan • Band pass & notch tuning • Computer control via MEC 71A & C64 • See ICOM's ads for more details

ICOM Options Free installation when purchased with your R71A from EEB

- CK-70: DC Kit for 13.8 VDC operation
- CR-64: High stability oscillator
- CK-70: DC kit for VDC operation
- CR-64: High stability oscillator
- EX309: Computer interface connector
- EX310: Voice synthesizer
- FL32A: CW narrow filter (500 Hz)
- FL44A: Crystal filter (2.4 KHz)
- FL63A: CW narrower filter (250 Hz)
- RC-11: Infrared remote control

Service Manual SMR71A \$25.00 + \$4.00 UPS

EEB HP Options

R71 (HP) High Performance. EEB has the reputation of excellence when it comes to R71A modifications. Many of our modifications are proprietary and not offered by any other source. EEB now offers a package deal including our most popular option—known as the R71(HP) High Performance and includes the following:

- 24 hour bench test.
- Narrow filter (choice of 3, see below). Replaces stock ceramic SSB filter. Improved selectivity and shape factor.
- Front end upgrade—improves dynamic range (plus) preamp enabled below 1600 KHz.
- 4 KHz filter replaces stock. 6 KHz wide filter—improves AM selectivity.
- Audio output modification—increases audio output; reduces distortion.
- AGC time constant changed to better suit SW listening.
- Spike protection added.
- RFI line filter.
- Installation of ICOM options purchased with your R71A HP.
- Final alignment and overall checkout.
- Free extended 6 month warranty.

R71HP (MF) Mechanical Filter add \$200
R71HP (XF) 8 Pole, 2.4 KHz xtal filter add \$250
R71HP (XFS) Super 2.1 KHz filter add \$300

NRD-525 General Coverage Receiver

- 90 kHz to 34 MHz
- Options for 34-60 MHz, 114-174 MHz and 423-456 MHz
- 200 Memory Channels
- 2 Clocks/Timer To Control Radio & Extra Equipment (tape recorder)
- Computer Interface Option.



**Sale Price
\$1179.00**

IBS WHITE PAPER

Larry Magne - a name you can trust - 'speaks out' with detailed test reports. Know the facts before you buy!

- RD2: ICOM ICR71A
- RD3: KENWOOD R5000
- RD4: HOW TO Interpret Specifications
- RD5: JAPAN RADIO NRD 525
- RD6: YAESU FRG8800
- RD7: LOWE HF125
- RD8: SWL ANTENNAS
- RD9: SONY ICF2010
- \$12.00 FOR 3 + \$1.95 POST

ORDER DESK HOURS (Eastern):
MONDAY-FRIDAY 10 A.M. to 5 P.M.
SATURDAY 10 A.M. to 4 P.M.
 Technical and VA orders call (703) 938-3350

Electronic Equipment Bank
 516 Mill Street N.E., Vienna, VA 22180
 Telephone (703) 938-3350

STORE HOURS (Eastern):
 Same as Order Desk Hours
 Closed Mondays
 Thursday 10 A.M. to 9 P.M.

Electronic Equipment Bank—Order Toll Free 800-368-3270

VHF - UHF

YAESU FRG9600



60-905 MHz

Service manual
 order: SM9600
 price: \$25.00

\$499.95

+ \$7.00 UPS
 A premium VHF/UHF scanning communications receiver.

- You won't miss any local action with continuous coverage from 60 to 905 MHz.
- You have more operating modes to listen in on: upper or lower sideband—CW, AM wide or narrow, and FM wide or narrow.
- Plus there's much more, including a 24-hour clock, multiplexed output, LCD readout, signal strength graph, and an AC power adapter.

OPTIONS: FIF-232C for RS232 compatible computers; \$69.95. VU-9600 for tuning in TV stations with your 9600 and video monitor, \$25.00. 99 memories.

ICOM R-7000



\$949.00
+ \$10.00 UPS

Service manual
 order: SMICR7000
 price: \$25.00

Commercial Receiver
VHF-UHF 25-2000 MHz

- 25-2000 MHz coverage
- Precise frequency entry via keyboard
- 96 programmable memories
- Scan-memory-mode-select memory-frequency
- 5 tuning speeds: 1, 1.0, 5, 10, 12.5, 25 KHz
- Narrow/wide filter selection
- Memory back-up • Noise blanker
- "S" meter or center meter for FM
- AM & FM wide, FM narrow. SSB, CW

EEB HP Options

- Front end upgrade improves sensitivity
- Audio mod—better volume, less distortion
- Optional band pass filters
- Power supply cooling mod to reduce chassis heat • Spike protection, on AC line
- IF output for spectral display 10.7 (STD) 21.4, 30 MHz others available
- 24 hour bench test and realignment for optimum performance
- Extended warranty to 6 months
- Final alignment and overall checkout
- Installation of ICOM options purchased with your new R7000 at no charge

SCANNERS

RADIO SHACK!

PRO 31A

Handheld 10 channels, \$189.95 + \$4.00 UPS

PRO 32A

Handheld 200 Channels, \$289.95 + \$4.00 UPS

PRO 2021

Tabletop/Mobile 200 Channels,
 \$279.95 + \$6.00 UPS

PRO 2004

Tabletop 300 Channels, \$379.95 + \$6.00 UPS



- We ship world-wide
- Shipping charges not included
- Prices & specifications subject to change without notice

SCANNERS CONT.

SPECIAL SALE LIMITED QUANTITIES

J.I.L. SX-200

- 26-88, 108-180, 380-512 MHz
- 16 Memory Channels
- Table/Mobile • 13.8 VDC
- Dual Scan Speed • AM, FM
- Metal case • DX Local switch

\$199.95 + \$6.00 UPS

AR2002 SCANNER

- 25 MHz to 550 MHz & 800 MHz to 1300 MHz
- FM (wide & narrow) and AM
- LED "S" meter • Scanning
- Optional RS232 socket on rear!
- Professional class performance

\$449.95 + \$6.00 UPS

RTTY-CW-FAX

RTTY - CW - AMTOR

SPECIAL SALE
WHILE SUPPLIES LAST!

AEA CP-1 Computer Patch



As Low As:
\$215.00!!

* Copy Morse Code, 5-99 wpm, RTTY, Ascii, Amtor. All you need is a stable Receiver, a computer, a CP-1 & the Software. Choose one of our package Deals for best price break. CP-1 Interface and software for the following: C64/C128 \$269.00 IBM PC \$269.00 APPLE IIe \$215.00 + \$4.00 UPS.

AMECO Tunable Pre Amp-Antenna



- Matches Most Any Antenna
- Improves Gain and Noise Figure
- 9V Battery PWR (not included)
- AC Adapter Optional (\$9.95) (Order - P9T)

• 200 kHz-30 MHz
 • Preselector
 • Indoor Active Antenna **\$74.95 + \$4.00 UPS**

ANTENNAS

EAVESDROPPER SALE

\$59.95 + \$4.00 UPS

- Balanced trapped Dipole
- Maximum performance, Minimum local noise
- All SW Bands 60-11 meters
- Only 43 feet long - 100 ft. feed line
- Complete - Everything you need.

MFJ 1024 \$119.95 + \$5.00 UPS

A.C. Adapter \$9.95

- Outdoor active antenna
- Performs as well as units costing \$180.00
- WRTVH rates it high

ICOM AH7000

\$89.95 + \$4.00 UPS

Discone Antenna for ICR7000/others w/type 'N' antenna connector. 25-1300 MHz!

50' of Lo-Loss Coax Cable Included.

D-130 ANTENNA

\$79.95 + \$4.00 UPS

Same as above but with PL-259 connector.
 50' of Coax Cable Included.

NEW FROM EEB

ALL NEW FROM SONY!
WORLD BAND RADIO
THE NEW ICF-7700



- 15 Bands-12 SW, MW, LW & FM
- 15 Station memory presets
- LCD Frequency readout
- Built in clock & sleep timer
- 4 1/2" x 7 1/2" x 1 1/4"
- Earphone, carrying case, SWL book included. AC-D4L Optional AC Adaptor \$21.95

\$249.95 + \$4.00 UPS

DON'T LET ITS SMALL SIZE FOOL YOU! A FULL FEATURED RADIO THAT WILL FIT IN YOUR POCKET. THE ULTIMATE IN PORTABILITY!

SONY ICF—PRO80

ONLY \$349.95
+ \$4.00 UPS



SONY CALLS THIS RADIO THE 'PRO80' & HERE'S WHY:

- Covers 150 kHz to 216 MHz!! (with supplied converter)
- AM, FM, (wide & narrow); SSB • 40 Station Memories!
- Memory scan, Program scan, Limit scan, up/down manual scan and priority scan!
- Automatic and manual squelch!
- Handheld radio 3 1/2" x 7 1/4" x 2" and weighs 1lb. 7 oz.
- Rechargeable battery Pak (opt) • Comes with telescopic antenna, shoulder belt, carrying case, wave book, frequency converter and BNC adaptor.

PANASONIC RFB60
Compact multi-band radio

- PLL synthesized receiver
- 6-way tuning system
- Clock/Timer with Sleep
- LCD Readout

CALL FOR PRICE

LOWE HF-125
NEW HF RECEIVER

- 30 kHz TO 30 MHz • AM, SSB
- 30 Memories • 12 Vdc
- 4 Filters (selectable)
- OPTIONS: Nicad battery, keypad frequency entry, ECSS system.

CALL FOR PRICE

SIGNAL DISPLAY UNIT!
FOR THE ICR7000 & OTHERS

\$1295.00
+ \$8.00 UPS



SPECIFICATIONS FOR THE SM1071

- Frequency range 10.2 to 11.2 MHz
- Sensitivity: 0.5uV min discernable signal
- Gain control range: 70 dB min.
- 2.5" x 2.0" Screen
- Log range: approx 60 dB
- 50 ohm nominal input impedance
- Size is 6" x 4" x 10.5
- Log range is approx 60 dB

10 miles west of Washington, D.C.

Sorry—No COD's

10-5 Tues., Wed., Fri. 10-9 Thursday

10-4 Saturday Closed Sunday and Monday



ELECTRONIC EQUIPMENT BANK
 516 Mill Street, N.E.
 Vienna, VA 22180
Order Toll Free: 800-368-3270
 Technical and VA Orders (703) 938-3350

GETTING STARTED AS A RADIO AMATEUR

Those New Micros Aren't Toys

ICOM, Kenwood and Yaesu make them: radio Amateurs call them *micros*. Micros are tiny handheld VHF and UHF FM transceivers. The first time I played with a micro, my eyes just about popped out of my head! All the guts of the radio—including receiver, 1-watt transmitter, speaker, mike and dual-tone, multifrequency (DTMF, often called Touch-Tone) keypad—fit into a case just 1¼ inches deep, 2¼ inches wide and 3 inches long! My bet is that if you're a Ham, you'll hear Hams talking about these gadgets on your local repeater. Micro scanners are on the market, too.

Believe it or not, in the 18 years I've been a Ham, I'd never owned any sort of handheld before. I hadn't needed a handheld all those years; I didn't really "need" one now. What sold me was my micro's 140-163 MHz receiver coverage. It hauls in NOAA weather at 162.40, 162.475 and 162.55 MHz, as well as government, public service and safety channels above and below the 144-148 MHz Ham band. Our regional med-evac helicopter service, Lifestar, uses 155.385 MHz. One afternoon, I heard 'copter and base loud and clear—especially the 'copter, which passed low over my apartment on its way back to base!

The new micro handheld even worked well for two-way communication in the 2-meter Ham band! In and around Newington, I could "hit" the League's 2-meter repeater (W1AW/R, input frequency 144.85 MHz, output 145.45 MHz) reliably, even at the micro's "low" transmitter power (0.1 watt) setting. Yep, the new micro is a neat little toy.

Terror On I-84

A couple of weeks later, Mary (N7IAL) and I were driving back to Newington after ogling—and buying—radio goodies at the massive Hosstraders flea market in Deerfield, New Hampshire. Our friend Steve, N9ELJ, languished in the back seat of our four-day-old car, occasionally voicing gems of wisdom from the stack of 1930's *Radio* magazines I'd bought at Deerfield for twelve bucks. I had my 2-meter micro along. We'd used it for "caravan" communications on the way up, keeping in touch with the other Hams in our group on 145.555-MHz FM. [This simplex (non-repeater) Ham frequency is widely used by Hams on the road and at flea markets and Hamfests, so check it from time to time. You may get an earful.]

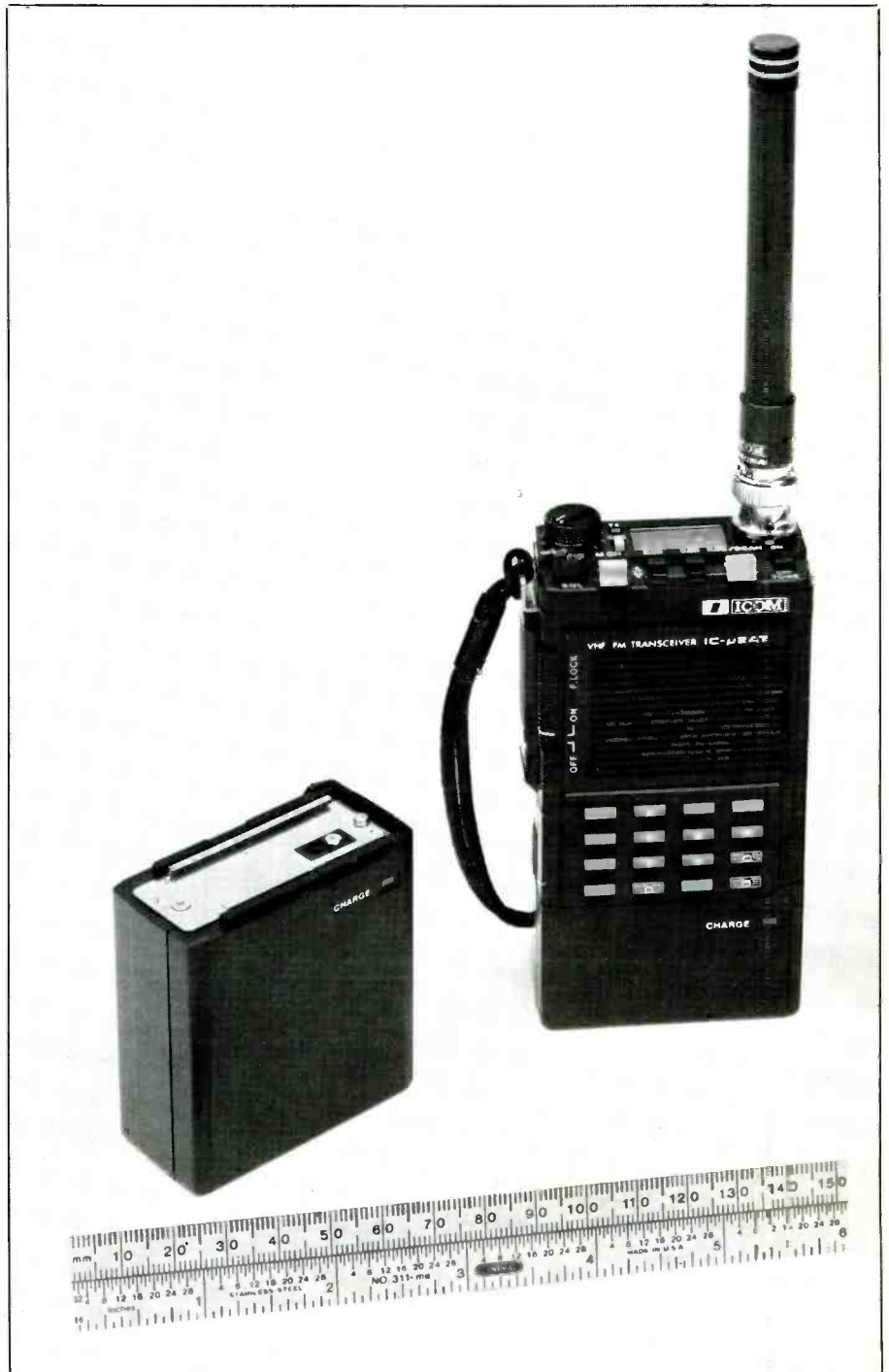

With ten memories and receiver coverage from 140-163 MHz, this tiny handheld Amateur Radio micro packs a palm-sized wallop. The optional battery pack at left allows longer operating stretches without recharging. ICOM makes this transceiver; Kenwood and Yaesu make micros, too.

We were about five miles out of Hartford, westbound in tight high-speed traffic on Interstate 84, when our brand-new car shuddered and quit.

What instincts we had failed us miserably. We'd "lost it" in a heavy construction zone. There was no right-hand shoulder. We had nowhere to go but forward. The car wouldn't go forward, so we went *nowhere*. We were seconds away from being rear-ended. Emergency blinkers! Mary couldn't find the switch. The car was too new for her to act instinctively. Steve, who owns a (working) version of our car, told her how to get the blinkers going. Then he and I jumped out into traffic to push.

Good—now we'll get it before the rear end of the car does. Push! Don't block the blinkers! There's shoulder *fifty yards ahead*, up an incline. Don't look back! We stare down at the pavement and push for our lives. The car is an automatic with power steering. As we head up the hill, the car drifts out toward traffic.

Here, I make my big mistake. I know Mary can't hear my shouts over the roar of the traffic, so I jump alongside the car, hurl open the door and tell her to steer harder to the right. The car rolls backward; we've lost all the momentum we had.

The Marines land. From out of nowhere, a man jumps alongside me and pushes with us. The three of us push the car onto the shoulder. For several minutes, we can only gasp for air.

Mop-Up With The Micro

You're probably waiting for me, the POP-COMM Ham radio columnist from ARRL HQ, to tell you how Ham radio saved the

day. *It didn't!* We had no time for Ham radio heroics with freeway traffic breathing down our, uh, necks. With the car safely off the road, however, Ham radio *did* help us *clean up* the day.

Very "conveniently," our car had broken down just three miles away from our car dealer's. The couple who'd stopped to help us drove Mary to the dealership. (Yes, Mary had brought *her* 2 meter handheld on the Deerfield trip, too.) Steve and I stayed with the car—and my "toy" micro handheld. Communicating through the Vernon, Connecticut, repeater (WA1KGG/R, 146.19 MHz input, 146.79 MHz output), Mary and I kept in touch, helping the car dealer coordinate the tow.

The couple who stopped to push us wouldn't tell Mary their names. Steve and I could *not* have pushed the car up the hill and off the road without their help. Also unidentified: the gutsy driver who pulled up a few tens of yards behind us and used *his* blinkers and waving arm to divert traffic as we pushed. We *can* thank the Pioneer Valley Repeater Association for the 19/79 repeater—and we also thank the Ham who heard our car-repair bleatings on the 19/79 repeater and stopped to be sure Steve and I had the situation under control.

No police cars passed us in *either* direction for the entire duration of the adventure, but we hadn't asked for police assistance, anyway. As for the guy in the Rolls-Royce who pulled over, walked to us with map in hand, and asked Steve and me for directions *without once asking about our situation*, well . . .

My micro: I think I'll keep it. I no longer consider it a toy.

PC

Plan To Move? Let Us Know.

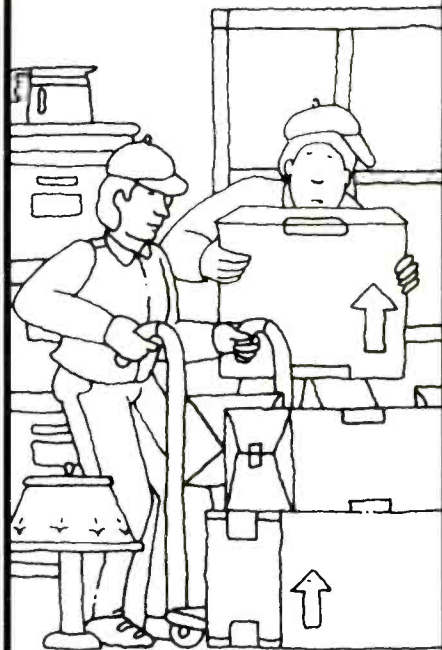

PLEASE PRINT

ATTACH LABEL HERE

NEW ADDRESS HERE

NAME _____

ADDRESS _____

CITY _____ STATE _____

DATE _____ ZIP _____

SUBSCRIBER SERVICE CHANGE OF ADDRESS

Planning to move? Please let us know six weeks in advance so you won't miss a single issue of POPULAR COMMUNICATIONS. Attach old label and print new address in space provided. Also include your mailing label whenever you write concerning your subscription to insure prompt service on your inquiry.

POPULAR COMMUNICATIONS
76 N. Broadway,
Hicksville, NY 11801



Over 75,000 active amateurs in over 125 countries read a different kind of ham magazine every month. They read CQ.

SUBSCRIBE TODAY!

CQ
The Radio Amateur's Journal
76 N. Broadway, Hicksville, NY 11801

Please send me CQ for Life 3 Years 2 Years 1 Year
 New Renewal Start with _____ issue

Name _____ Call _____
Street _____
City _____ State _____ Zip _____

Charge My Order To: Payment Enclosed \$ _____
3 Years (36 issues) \$52.00
2 Years (24 issues) 35.00
1 Year (12 issues) 18.00

MasterCard My account number is _____
VISA



PRODUCTS

REVIEW OF NEW AND INTERESTING PRODUCTS

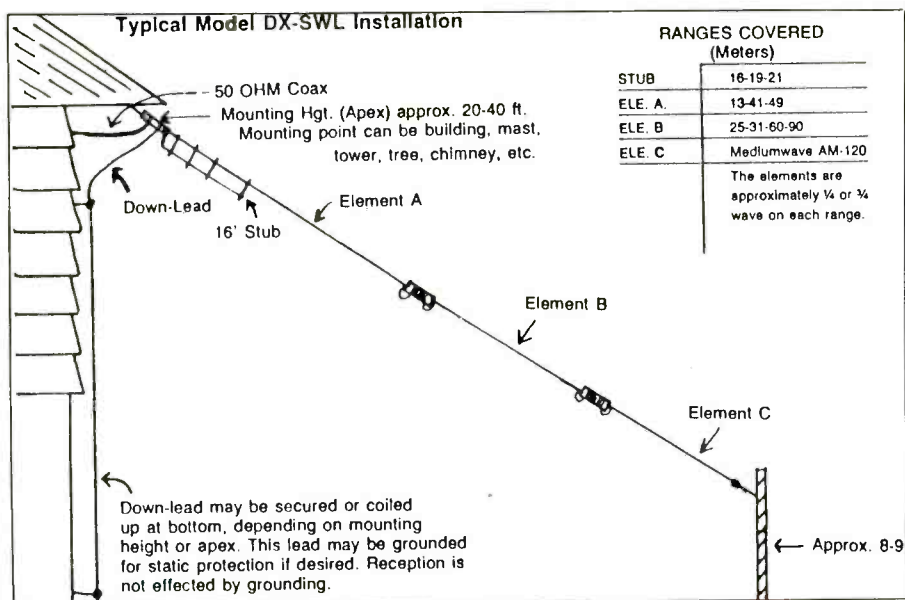

SW "Sloper" Antenna

Universal Shortwave is pleased to introduce the new Alpha Delta DX-SWL Sloper

Antenna. The sloper design, popular with Hams for years, allows easy installation. Only one end of the antenna needs to be elevated (25' or higher). This antenna covers

mediumwave, all the major shortwave bands plus the 90 and 120 meter bands usually overlooked by most dipole antennas.

The overall length of the slope wire is only 60'. It includes a single 50 ohm coaxial feed point (for PL259) at the apex, for user-supplied 50 ohm coaxial lead-in. The American-made DX-SWL Sloper is constructed with heavy duty components and stainless steel hardware. It utilizes broadband low-Q RF choke-resonators for efficient multiband frequency selection (instead of high-loss narrow band traps). It is fully assembled and requires no adjustments or "trimming." The DX-SWL Sloper is available now for \$69.95 plus \$2.75 shipping, exclusively from Universal Shortwave, 1280 Aida Drive, Reynoldsburg, Ohio 43068.

For more info, you may also circle number 104 on the reader service card.

Cellular Look-alike CB Antennas

Midland International has added two innovative CB antennas to its complete line of portable, mobile and base station CB radios and accessories.

BOOKS
ACCESSORIES
ANTENNAS

SWELL SWL DISCOUNTS

Factory Authorized
Service for Icom
Kenwood &
Yaesu

Orders & Quotes
Toll Free—

National:
800-336-4799

New England:
(except New Hampshire)
800-237-0047

Virginia:
800-572-4201

ege, inc.

Virginia
14803 Build America Drive
Building B
Woodbridge, VA 22191
Customer Service: (703) 643-1063
Service Dept: (703) 494-8750
Hours—M-Th: 10-6;
Fri: 10-8; Sat: 10-4

ege, inc.

New Hampshire
8 Stiles Road
Salem, New Hampshire 03079
Customer Service & New Hampshire Orders: (603) 898-3750
Hours—MTuWSat: 10-4;
ThF: Noon-8



KENWOOD

R-5000
All-mode listening 100 kHz -30 MHz. Optional converters to cover the 108-174 MHz range. 100 memories.

R-2000
150 kHz - 30 MHz for AM, FM, SSB, and CW listening. 10 memories.



ICOM

R-71A
Receive 100 kHz - 30 MHz. For AM, SSB, CW, RTTY, & optional FM. 32 memories.

R-7000
25-100 MHz (1.24-1.3 GHz) coverage for SSB, FM, & AM. 99 memories.



YAESU

FRG-8800
Listen to AM, SSB, CW, FM narrow and wide 150 kHz-30 MHz. 12 memories.

FRG-9600
Compact receiver for FM, AM, SSB with a range of 60-905 MHz (up to 460 MHz for SSB). 100 memories.



SANGEAN

SWL radios for AM/FM. Call for more information and quotes.



TEN-TEC
RX-325
Covers AM, SSB, CW 100 kHz to 30 MHz. 25 memories.

SONY

ICF-2002, ICF-2010, and ICF-7600A are compact receivers for SWL. Call for quotes.

CBs
& Radar
Detectors
Uniden, Cobra,
Midland, & Whistler

Scanners

Regency
Beacon
At Super Discounts

CIRCLE 95 ON READER SERVICE CARD

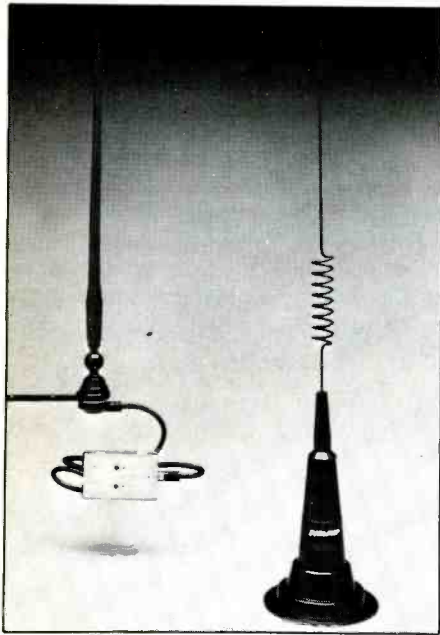

Midland Model 18-2985 is a new cellular look-alike magnetic mount antenna with the unique air-wound cellular style coil. The antenna's whip is tough 17-7 stainless steel in jet black. Midland's Hi-Pro coil assures maximum coverage and talk power. Model 18-2985 is pre-wired, factory tuned, skin-packed in a display package, and has a suggested list price of \$34.95.

Model 18-236, another new Midland mobile antenna, includes a splitter to run AM/FM standard broadcast radio plus CB radio. With a rugged 16" rubber mast and 12 feet of cable, this new antenna is well-suited for cars, trucks, vans, RV's, and motorcycles. Suggested retail price is \$29.95.

For more information on Midland's new CB antennas, contact Midland International, Consumer Products Division, 1690 N. Topping, Kansas City, MO 64120, or circle reader service number 101.

Novice Enhancements

Heathkit updated computer-assisted instruction (CAI) software is now available to meet the FCC's new *Report and Order*, effective 0001 UTC (March 21, 1987) for Amateur Radio operators. This computer software offers FCC-approved questions for all five elements, including the latest "enhanced" Novice Class, Technician Class and General Class.

Menu-driven programs on disk feature all nine sub-elements plus the entire data base of FCC-approved questions. Users can create sample tests with multiple choice questions and a CW practice program. The computer software can be used with Heathkit, Zenith Data Systems, IBM and other PC-compatible computers.

Wayne Wilson, Product Line Manager for Heathkit Amateur Radio products, says, "Now that the FCC is giving Novice Hams phone privileges and new band allocations, it's a great time to enter the world of Amateur Radio. Our guaranteed Novice and

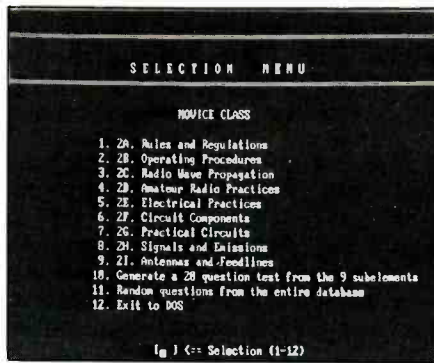

Fig 1 ← Selection (1-12)

General class courses, now enhanced by the introduction of this software, make it easy for them to do so."

For more information about the Heathkit line of Amateur Radio products or other Heathkit products, circle number 103 on the reader service card, or, write Heath Company, Dept. 150-905, Benton Harbor, MI 40922. In Canada, write to Heath Company, 1020 Islington Avenue, Dept. 3100, Toronto, Ontario M8Z 5Z3.

New IC-900 Mobile Transceiver

ICOM introduces the first fiber optic multi-band (six bands) mobile transceiver available, the IC-900. This deluxe all-mode mobile transceiver allows you to operate six bands ranging from 10 meters to 1.2 GHz with one controller.

The IC-900 includes an ultra compact remote controller for remote mounting, an Interface A unit, Interface B unit, SP-8 speaker, HM-14 up/down DTMF microphone, fiber optic and controller cables.

Measuring only 2" high by 5.7" wide by 1" deep, the remote controller can be installed on your car's dash or sun visor with the supplied Velcro. The easy to operate mobile also comes equipped with a super large LCD for easy viewing.

The IC-900 allows the operator to listen on two bands simultaneously or transmit on one band while receiving on another band (true full duplex crossband operation). All subaudible tones are built-in and the actual subaudible frequency is displayed. Ten memories are available for each band, with capability of individual PL tone and offset programming.

Two scanning systems are available: programmable band scan and memory scan. Fiber optic technology enables a 3/16" cable to transport all data between Interface A (installed near driver's seat) and Interface B (installed in trunk or rear of vehicle). Fiber optic cable also eliminates RF feedback.

The IC-900 is available now. Suggested list price is \$589. The UX-29A 2-meter 25 watt band unit is also available now at a suggested list price of \$295. For more information circle number 102 on the reader service card or contact the Customer Service Department of ICOM America, Inc. at 2380 116 Ave. N.E., Bellevue, WA 98004.

DIAMOND

D-130 SUPER DISCONE WIDEBAND

Suggested Retail
\$79.95

Features

25-1300 MHz Super-Discone Antenna.
Transmit on 50, 144, 430,
1200 MHz Monitor 25-
1300 MHz with one antenna

Description

All stainless steel discone and vertical radiator for TX. Rugged Construction, wide bandwidth.

Gain (dBi)

0 dB

VSWR

1.5:1 or less

Input Power

50 Watts

Length

1.7 M

Impedance

50 Ohms

Weight

1 kg

Mount Model

Adapts to 25-50mm masts.

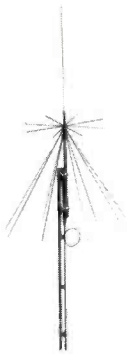

ENCOMM

1506 CAPITAL AVENUE, PLANO, TEXAS 75074
NATIONAL DISTRIBUTOR

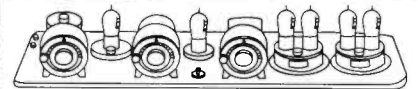

IF YOU BUY, SELL OR COLLECT
OLD RADIOS, YOU NEED...

ANTIQUE RADIO CLASSIFIED

Antique Radio's Largest-Circulation
Monthly Magazine

Articles - Classifieds - Ads for Parts & Services
Also: Early TV, Ham Equip., Books,
Telegraph, 40's & 50's Radios & more...

Free 20-word ad each month. Don't miss out!

Sample - Free, 6-Month Trial - \$10.

1-Year: \$18 (\$24 by 1st Class). Foreign - Write.

A.R.C., P.O. Box 2-T3, Carlisle, MA 01741

CIRCLE 98 ON READER SERVICE CARD

Since 1967, CRB Research has been the world's leading publisher and supplier of unique hobby and professional books and information including:

- Bugging
- Wiretapping
- Communications Antennas
- Electronics & Projects
- Fox Scanner Directories
- Computer Technology

Ask for our latest FREE catalog.

CRB RESEARCH

P.O. Box 56 Commack, NY 11725

CIRCLE 88 ON READER SERVICE CARD

THE EXCITING WORLD OF RADIOTELETYPE MONITORING

The desktop publishing revolution in microcomputing can be put to great use in your RTTY monitoring. Many of you already own personal computers to retrieve and store RTTY intercepts. You may even have a printer. But have you thought about adding a desktop scanner to your system? Or using desktop publishing software?

Adding a printer to your monitoring system is a great way to save that long-sought RTTY intercept you tried hard to get and to show it to others. You don't have to own a microcomputer to take advantage of this technology. You can easily hook up a printer to any RTTY demodulator that has a serial or parallel port without having to buy a computer. The demodulator will operate the printer.

If you don't have a printer you should consider getting one because it will free you to do other things. For instance, you may have latched onto a station idling in the TDM mode. Rather than sitting by the radio waiting for a RTTY broadcast and seeing no output for hours, you can go bowling or do some errands and let the printer babysit the station for you. Upon your return you may find a reward.

An optical scanner allows your microcomputer to read text and see images. You can take a RTTY printout from your printer and use the scanner to merge it with text on your word processing software. Your word processor can also edit the scanned text, erasing the garbage or garbling that came over the radio, and even change the text. Many ute monitors would consider this editing to be sacrilege, but we're only showing you some of the possibilities of using computers with your radio equipment.

In the same manner you can scan FAX charts and photos into your graphics software and touch up the images.

Using desktop publishing software, the scanned and edited text and images can be incorporated into a small newsletter or newspaper. If you are a member of a shortwave radio listening club that includes ute monitors, think of the ways that RTTY and FAX printouts can enhance your club's magazine or newsletter.

This month, using RTTY printouts, we intend to show a representative selection of utility RTTY stations.

For those of you who are unfamiliar with RTTY or are novices at tuning in RTTY stations, you will find it being used by many different types of utility stations. A utility station does not broadcast for public consumption as do shortwave radio, AM and FM radio, and television stations. Their communications are meant to be private.

Some of the many types we will be focusing on this month are ships and coastal marine stations, the military, weather stations, embassies, press services, aero and telecommunications stations, the United Nations, and one of the "mysteries" that becomes a puzzle for us monitors to solve.

Hundreds of ships use RTTY as do maritime coastal stations. Intercepts from them are the easiest ones for a novice RTTY monitor to receive.

In Figure 1, we see a printout (1) showing NMC, the U.S. Coast Guard station at San Francisco, CA sending a message to a ship with the call letters of WNRD. This intercept was on 17207 kHz in ARQ mode at 2155 UTC. Reference sources show the ship to be the *President Monroe*, a container vessel whose registered owner is the U.S. Department of Commerce. Its home port is San Francisco. The ship had been having problems in trying to contact NMC because it had been given incorrect frequencies. Hence the reply from NMC.

In (2), UKSY, *Akademik Boris Petrov*, a Soviet research ship, is sending a test tape of RY's to UNM 2, Klaipeda R., USSR, followed by a short message. "NIS" before the ship's name indicates that it is

Ships and Coastal Stations

1

WNRD DE NMC AT ESENT AMONLY XMITTIN 17205 WINDOW FEQ
17207 ASSIGNED AM ALSO SET UP BUT AM NOT PRESENLY XMITTING
ON 8712.5 WINDOW AT NIGHT WE XMIT ON 8712.5 AND
6502 IMI 65026 BOT WINDOW FREQS ... DID NMO HONO GIVE YOU
THAT INFO ON OUR SITOR FREQS ? ZB

2

RYRTRBLYRYRYRYRYRY UNM-2 UNM-2 DE UKSY UKSY #'-?
NIS AKADEMIK BORIS PETROW SVC 9 WR PPTP;
4-89 KLAJPEDA &4';
2817 SEW 4037"-0;4-89 UKSY-
....

3

?))LGB E ICQB GA TO YOU OM,
ALMARE SETTIMAXICQB 1 CK 13 14 1530UTC IU02
BULKTRADE
BERGEN
ALMAE ETTIMA ICQB ETA PORTSAID APRIL/30 1800LT
FOR TRANSIT SUEZCANAL
REGARDS
MASTER
NIL MORE PLS QSL? TK"?10)
OK RGR SAME TO YOU AND ALL LBEE LGB OPERATORS, PLS OM I I NEED
CHARGES FOR QTC TKS"?

4

CQ CQ CQ DE WOO WOO WOO
CQ CQ CQ DE WOO WOO WOO
GM/GE THIS IS WOO, OCEAN GATE RADIO, TESTING RTTY EQUIPMENT

5

CQ CQ CQ CQ FY Q CQ CQ LISTA DE TRAFICO DE DE EA EDJ66
6 EDK5 EDL4 LISTA E TRAFICO SS HERMANOS T W CQ

6

VIA RS
APR 01 16:31 GMT
39497 HEB CH
421777Z TRX CH
ZCZC BERN0003 GVF 175 PUBPWOI
PRPQXQPEPXQPEP
GOP
TN
M/V SENECA/A80Z 89 04/01/87 FROM TRAMARINE PHAP
ADVISE WHY CLEANING FOR OAL TAKNG LONGER THAN NORMALTRANSIT TIME
TO LOADPORT
TRAMARINE"GTN1830EP
01/1831 18:31 01 APR 87
NNNN

Figure 1

a research vessel that collects meteorology or hydrology data. This logging appeared on 6251 kHz at 2315 UTC, 50/170N.

Next (3) is the Italian cargo ship, *Almare VII*, call letters ICQB, sending a Telex via LGB, Rogaland Radio, Norway, stating that the ship is expected to reach the Suez Canal in another 16 days. This printout was from 12501 kHz at 1600 UTC in ARQ. WOO, Ocean Gate Radio, New Jersey, tests its equipment (4) in the FEC mode at 1945 UTC on 8051.5 kHz. EDK 5, Aranjuez Radio Spain (5), calls CQ for its traffic list in 13082 kHz at 1915 UTC in FEC. Lastly, HEB, Bern Radio, Switzerland, sends a Telex (6) to A80Z, *Seneca*, an ore carrier registered in Liberia, on 13080 kHz at 1812 UTC, in ARQ.

Moving on to the weather stations, in Figure 2 you will find some of the formats used in weather broadcasts. The data in five-digit groups is from (1) JMG 4, Tokyo Meteo, Japan (14880 kHz, 2131 UTC, 50/850R); (2) 3BT 4, Vacaos Meteo, Mauritius (15955 kHz, 1547 UTC, 50/600R); (3) LZU 2, Sofia Meteo, Bulgaria (11063 kHz, 1701 UTC, 50/425R); and (4) DDK8, Frankfurt Meteo, West Germany (11637.5 kHz, 1601 UTC, 50/425R); and (5) USZ, Soviet Arctic Meteo Station, Dikson, USSR, (along with RY's, showing poor reception on 11105 kHz at 2347 UTC, 50/425N).

The plaintext weather forecast (6) from Environment Canada,

POPULAR COMMUNICATIONS BOOK SHOP

Ameco Amateur Radio FCC Test Manuals

Each book contains the latest FCC VEC test questions, plus ARRL multiple-choice answers followed by a complete, simplified discussion of each question written in an easy-to-understand style.

Novice Class, 96 pages, paperback, \$4.95. Order #H221.
General Class, 128 pages, paperback, \$4.95. Order #H034.
Advanced Class, 128 pp., paperback, \$4.95. Order #H035.
Extra Class, 128 pages, paperback, \$4.95. Order #H220.

The Joy of QRP

by Adrian Weiss. K8EEG/WØRSP

For QRP enthusiasts, this new book by QRP expert Ade Weiss covers everything from the basics through the fine points in 8 chapters. Includes approximately 50 tables, photos, and drawings. 151 pages, paperback, \$10.95. Order #H222.

The Radio Publications Group—The "Bill Orr Series"

These easy reading classics belong in the library of any active ham. Loaded with practical how-to information, with tables, charts, and formulas arranged for handy reference.

Beam Antenna Handbook, 200 pages, paperback, \$9.95. Order #H143.

Wire Antennas, 192 pp., paperback, \$7.95. Order #H144.

Antenna Handbook, 192 pp. paperback, \$9.95. Order #H145.

Cubical Quad Antennas, 112 pages, paperback, \$7.95. Order #R146.

Vertical Antennas, 192 pages, paperback, \$10.95. Order #H303.

VHF Handbook, 336 pp. paperback, \$11.95. Order #H147.

Interference Handbook, 247 pages, paperback, \$9.95. Order #H172.

World Radio TV Handbook 1987

The world's only complete directory of international broadcasting and TV stations—the established, authoritative guide endorsed by the world's leading broadcasting organizations. A comprehensive country-by-country listing of short-, medium-, and long-wave stations revised and updated to reflect actual conditions. Also includes special features on The Future Regulation of High-Frequency Broadcasting, Solar Activity in 1985, Technical Innovations at Radio Nederland's New Transmitting Station, and more. 600 pages, paperback, \$19.50. Order #H097.

Radio Handbook, 22nd ed.

by Bill Orr, W6SAI

A state-of-the-art, single-source reference on radio communications and theory for hams, professional ops, techs, and engineers. New coverage includes solid-state devices, Yagis and quads, and h.f. amplifier designs. A hands-on instruction manual, as well. 1168 pages, hardcover, \$39.95. Order #S197.

World Press Services Frequencies

by Thomas Harrington

A comprehensive manual covering the field of radioteletype news monitoring—antennas, receivers, terminal units, monitors, and more. Contains 3 master lists of times of transmission, frequencies, plus ITU list of over 50 news services worldwide. 72 pages, paperback, \$8.95. Order #H173.

Computer Programs for Amateur Radio

by Wayne Overbeck and James A. Steffen

A comprehensive collection of BASIC programs for radio amateurs that can be used on the Apple, TRS-80, and Commodore 64, with conversions for the IBM PC. Includes contest logging, VHF operation, antenna design improvement, gray-line calculations, and more. 224 pages, paperback, \$16.95. Order #H218.

The Shortwave Propagation Handbook, 2nd ed.

by George Jacobs, W3ASK, and Theodore J. Cohen, N4XX
 A new, revised edition of the popular guide to all your propagation needs. Contains up-to-the-minute information and charts, and guides you through producing your own propagation data. 154 pages, paperback, \$8.95. Order #H137.

Ameco Novice Code and Theory Package

A complete training package containing the 128-page Novice theory course and a 60-minute code cassette, which teaches how to send and receive code up to 8 words per minute, and a 32-page book. Also included are FCC-type code and theory examinations to help even a rank beginner get a ticket fast! \$8.95. Order #H024.

RTTY Today

by Dave Ingram, K4TWJ

A brand new, completely up-to-date handbook on RTTY, covering the latest developments and techniques, plus use of the home computer for RTTY. Illustrated with photos, diagrams, station setups, and RTTY gear. 112 pages, paperback, \$8.95. Order #H211.

Vertical Antenna Handbook, 2nd ed.

by Paul H. Lee, N6PL

Out of print for several years, this classic has been reprinted with updates, including an addendum on antenna design for 160 meters. Other sections include feeding and matching, short verticals, ground effects, and much more. 139 pages, paperback, \$9.95. Order #H208.

The Complete DX'er

by Bob Locher, W9KNI

Covers every significant aspect of DXing from how to really listen to how to snatch the rare ones out of the pileups. Also includes advice on siting, equipment selection, and antennas. 187 pages, paperback, \$10.95. Order #H209.

POPULAR COMMUNICATIONS

76 N. Broadway, Hicksville, NY 11801

QTY.	ORDER #	TITLE	PRICE	TOTAL

Book Total

Shipping Charge

Grand Total

Shipping charges \$2.00 per order. Shipping charges waived on orders of \$50.00 or more. Books shipped best way. All orders are processed the day they are received, but please allow 30 days for delivery within North America.

Name _____

Address _____

City _____

State _____ Zip _____

Check MasterCard VISA

Card No. _____ Expires _____

X _____

Signature required on all charge orders:

RECEIVE RTTY/ASCII/CW on your Personal Computer



RTTY/ASCII/CW SWL COMPUTER INTERFACE MFJ-1225 **\$69.95**

FREE MFJ RTTY/ASCII/CW Software TAPE AND CABLE FOR VIC-20 OR C-64. ORDER MFJ-1225/MFJ-1264 FOR VIC-20 OR MFJ-1225/MFJ-1265 FOR C-64.

Receives commercial, military, and amateur RTTY/ASCII/CW using your personal computer.

The MFJ-1225 Computer Interface plugs between your receiver and VIC-20, Apple, TRS-80C, Atari, TI-99, Commodore 64 and most other personal computers. Requires appropriate software.

Copies all shifts (850, 425, 170 Hz shift and all others) and all speeds. Automatic noise limiter suppress static crashes for better copy. 2 LED tuning indicator makes tuning fast, easy, positive. 4 1/2 x 1 1/4 x 4 1/4 in. 12-15 VDC or 110 VAC with optional adapter, MFJ-1312, \$9.95.

INDOOR TUNED ACTIVE ANTENNA

MFJ-1020 **\$79.95**



MFJ-1020 New Indoor Active Antenna sits on your desk ready to listen to the "Rivals, often exceeds, reception of outside long wire. Unique Tuned Active Antenna minimizes intermode, provides RF selectivity, reduces noise outside tuned band. Also use as preselector for external antenna. Covers 300 KHz to 30 MHz in 5 bands. Adjustable telescoping antenna. Controls: Tune, Band Selector, Gain, ON-Off/Bypass, LED, FET, bipolar circuitry. Phonejack for external ant. 6x2x6 in. 9-18 VDC or 9V battery. 110 VAC with adapter, MFJ-1312, \$9.95.

REMOTE ACTIVE ANTENNA

54 inch remote active antenna mounts outdoors away from electrical noise for maximum signal and minimum noise pickup. Often outperforms long wire hundreds of feet long. Mount anywhere atop houses, buildings, balconies, apartments, mobile homes, on board ship.

Use with any radio to receive strong clear signals from all over the world. 50 KHz to 30 MHz.

High dynamic range eliminates intermodulation. Inside control unit has 20 dB attenuator, gain control. Switch 2 receivers and auxiliary or active antenna. "On" LED. 6x2x5 in. 50 ft. coax. 12 VDC or 110 VAC with MFJ-1312, \$9.95.

MFJ-1024 **\$129.95**

Order from MFJ and try it. If not delighted, return within 30 days for refund (less shipping).

One year unconditional guarantee.

Order yours today. Call toll free 800-647-1800.

Charge VISA, MC. Or mail check, money order.

Add \$4.00 each for shipping and handling.

CALL TOLL FREE ... 800-647-1800

Call 601-323-5869 in Miss., outside continental USA, tech/order/repair info. TELEX 53-4590

MFJ ENTERPRISES, INCORPORATED
 Box 494, Mississippi State, MS 39762

CIRCLE 91 ON READER SERVICE CARD

NEW AND EXCITING TELEPHONE TECHNOLOGY

Is Your Phone Tapped?

At some time or another, we have all had a moment of doubt about a phone line we were talking on. Our fears are fed by Hollywood, and the script is all too familiar: "What's that clicking?" "Did you hear that?" "Your voice just got louder." All about as believable as Hollywood radio talk, "Come in . . . Over."

Supposedly, a tapped phone makes clicking sounds, the level changes, you hear funny sounds—anything that would not be a perfect connection can be put down to a tapped phone. It is easier to find out if someone is reading your mail than if your conversations are being listened to. If you hear clicks and think your phone is tapped, you are either up to no good or suffering from paranoia.

Funny noises on the phone are as meaningful as creaks and groans in an old house at night. There could be an intruder, the dog could be looking for a warm spot, or the house may be settling down.

What exactly is a phone tap? It is a means of extracting audio from a phone line. There are several ways to do this; it can be as simple as a pick-up coil near a phone line. It can be as complex as a room full of tape recorders, computers and test equipment.

There are companies that feed on phone users' paranoia and claim to be able to give a phone line a clean bill of health. Many companies are charlatans. Some companies sell very overpriced test equipment that will only tell you how well the phone line is working, not how many taps are on it, if any. At the bottom end of the "Peace of Mind" market are a few companies selling devices with red and green LED's on them. One screws into the mouthpiece of a standard desk phone, others plug into the phone line with a modular plug.

How do these devices work? They measure the voltage on the phone line. With one phone off-hook, the voltage will be a reasonably stable voltage between, say, 9 and 3 Volts DC. When another phone is taken off-hook, the voltage will drop further. This further voltage drop lights the red LED. This device assumes that any attachments or phones going off-hook do so after the first phone is in use. The other phone going off-hook will also cause a click and lower the receive volume. A cheap DC voltmeter can also sit across the phone line and indicate that another phone is off-hook. These devices are very handy for deaf people who would like to know if an extension has been picked



Battery-operated portable Time Domain Reflectometer. Just the job for checking the integrity of your phone line or finding where rats have been gnawing at the cable.

up. At \$50 or so these tap detectors are a rip-off for security purposes.

Is there a fast cheap way to find out if your phone is tapped? Not really, but here is a fast questionnaire that will indicate the likelihood of a line being tapped:

- Do You Deal Drugs? Y___ N___
- Are You Involved In Organized Crime? Y___ N___
- Are You Active In A Radical Political Movement? Y___ N___
- Are You A Terrorist? Y___ N___
- Are You A Diplomat? Y___ N___

If you answer yes to any of these questions, you have good reason to suspect that your phone is tapped—no matter how smart you think you are.

There are several places to attach a phone tap. The first, and the one Hollywood likes to show us the most, is right in or beside the target phone. This is the most dangerous tap to place, unless tapping the phone of a spouse, roommate or colleague. It is also the easiest tap to find. The tap would normally be either a small transmitter (usually working on the low end of the FM broadcast band), a tape recorder (hard to

hide and it needs servicing), or hard wire leading from the room or premises to a listening post.

The next place to attach a tap is at some junction point. In an office block or business district, this is quite simple. Most office buildings have a "phone closet" on every floor. On each floor, the same phone lines will appear. In a business or industrial "park," the same phone lines will tend to appear in each building. Listening in to the company on the second floor or the firm across the park is not too difficult.

In a business setting, if the tap is made away from the target company's premises, only the "trunks" or phone company lines can be tapped. This will only look at outside calls and not be able to listen in on internal "intercom" calls. Also, identifying an individual caller rather than a company, if an individual is the target, can be tricky if the tap is not actually on an individual's extension but a trunk used by any employee at random.

There is an exception to the above scenario. If a company uses CENTREX, each extension is actually a phone line and the phone company exchange acts as the PBX or "phone system." Each phone line in a CENTREX set up is a real phone line

and can be dialed direct; it also works as an extension and can call any other CENTREX extension in the same group. Therefore taps placed on CENTREX lines can be precisely targeted.

A tap could also be dropped across a phone line at any of the many junction points between the target phone instrument and the exchange. Considering that the average phone distance between a subscriber and the exchange is three miles, there are plenty of opportunities for hanky-panky somewhere down the line.

One of the best and safest places to put a phone tap is in the exchange or "Central Office" as the phone company calls it. Any subscriber suspecting a tap on his or her line will have trouble gaining access to the Central Office and tracing his pair of wires through the building to make sure there is nothing suspicious or illegal attached to them.

The most difficult tap to find would be a "cross connect" or pair of wires attached to the target pair and then leading out of the Central Office to a listening post somewhere else—even at the other end of the country. The target could be three miles east of the Central Office and the listening post three miles west of the Central Office. Okay, wise guy, now find the tap—it's in this city somewhere. If "the Feds" are listening to your calls to the pizza parlor, there is no way you will know until the DA plays you the tapes.

Finding a tap is not easy and you can never be certain that a line is clean and secure. Even the U.S. Government admits that their lines could be tapped. With enough equipment and access to the right places, anyone can place an almost undetectable tap on a line.

A telephone subscriber may have reasons to consider that someone has placed a tap on his line. A businessman or diplomat overseas could consider that a phone is tapped. With good reason to consider that a tap is in place, there has to be a way to locate one. If the tap is "on the premises," the best way to find it is with a physical search. If it is near the site, a physical search is also in order.

There is one piece of test equipment that will not one hundred percent locate a tap, but will give the subscriber an idea that the line has been altered since the last measurements were made. This piece of test equipment is known as a Time Domain Reflectometer (TDR). It is a "radar set" for wire. It sends a signal down a pair of wires and when the impedance changes due to splices, water, breaks, shorts, etc., some or all of the signal will be reflected back to the instrument. A display CRT will show the distance to the anomaly and degree of the impedance change. On some models, a digital display will also show the distance to the "impedance hump" in feet.

This instrument, if used regularly, will show if anything has changed in the cable by comparing "signatures." The phone company uses this equipment to find faults in phone lines. Some unscrupulous "security" companies sell these devices at consider-

able markup as tap detectors. Those interested in a Time Domain Reflectometer should buy one at considerable savings from a telephone equipment manufacturer. One of the most portable and easy to use of these instruments is the model T11/1B from Canoga-Perkins in Chatsworth, California. The model T11/1B will set you back a tad over \$3,000, which is cheap if you use it every day to find bad telephone lines.

Another way to find out about taps is by "intelligence." Doing some sleuthing or buying information. Assuming a tap is found, what is to be done? If it is a "freelance" job and incriminating equipment has been found, the press can be called. In case of a freelance job, the law enforcement agencies and phone company security people can be called. The smart thing to do when a tap is found is leave it in place and then feed false and conflicting info down that phone line. When you know, don't let them know. With taps found in foreign countries, this is the best tactic, especially if the foreign country installed the tap.

Diplomats and foreign businessmen in Moscow live in special apartments. Also in these apartments are special listening posts keeping tabs on conversations in rooms and on the phones. Of course, the apartment managers deny the existence of these rooms behind closed doors, even when the tenants point out people leaving the non-existent rooms.

Spy novels make much of random surveillance of communications circuits. This is very easy when dealing with text. A computer can scan telex and computer lines looking for key words such as "secret" and lock on when a key word is detected. This is at present almost impossible to do with voice. The word "secret" can be said in many accents and dialects, let alone lan-

guages. These days, with so many long distance calls being routed via satellite, random surveillance requires only a TVRO station and a communications receiver.

If a computer can scan for say five key words spoken in any accent or dialect, what will it do with the other words? The whole conversation could be recorded on tape or stored digitally. Someone will then have to listen to the conversation. Computers are not yet smart enough to understand language and consider context. The phrase "What a way to recognize speech" could also be interpreted as "What a way to wreck a nice beach." We can tell what is meant by the context. Computers are still too dumb to figure it out.

The other problem with random surveillance is knowing who the two parties in a communication are. With text there are "answerbacks," account codes, passwords, etc., that identify the parties. This is not so on voice. Once a voice call has been dialed and connected there is no way for an eavesdropper to know who the parties are. To sum up, chances of random surveillance of voice calls are almost nil. Chances for random surveillance of text or data calls are pretty high. This may explain why so much data sent on phone lines and radio links these days is beginning to be encrypted.

Most governments have large agencies eating up massive amounts of cash listening to "the other side." This listening is referred to as "SIGINT." It tends to be limited to military and diplomatic traffic with very little to almost no commercial traffic. This listening is usually done on known channels or cables that carry that kind of traffic. Is there such a thing as a secure communications circuit? No. If there was, the NSA and other similar organizations would have no reason to be in existence.

PC

SUBSCRIBE NOW
& SAVE! - Twelve Issues \$16

SPECIAL!! BIG "D" Sale Prices



SONY ICF-2010
 SALE PRICE
\$306.50
 plus \$5.00
 Shipping U.S.A.

- 150 kHz to 20 MHz AM, CW, SSB
- 76 MHz to 108 MHz FM
- 116 MHz to 136 MHz AM Air Band

Regularly \$389.95

ICOM R7000A
 KENWOOD R-2000
 KENWOOD R-5000
 YAESU FRG 8800
 YAESU FRG 9600



ICOM R71A
 Prices ON REQUEST

- 32 Programmable memories
- 4 Event Timer
- Synchronous Detector
- Wide/Narrow Bandwidth

1-800-441-0145 (IN TEXAS) 1-800-527-2156 • ask for Ham Dept.

ALSO ASK ABOUT super saving prices on Kenwood, Icom, Encomm, Yaesu and all ham items.

electronic center, inc.
 ROSS AT CENTRAL EXPRESSWAY, DALLAS, TX 75201



SCANNER SCENE

BY CHUCK GYSI, N2DUP

MONITORING THE 30 TO 900 MHz "ACTION" BANDS

The letters are really pouring in here at POP'COMM, so I think we'll empty the mailbag onto the desk here in the shack and see who's checking in.

Michael Scofield of Anaheim, CA says he brought a handheld scanner more than a year ago and that he has a problem in which the unit internally generates a signal on any channel at random times. The signal lasts from 3 to 90 seconds, but generally averages about 15 seconds. He wonders what he can do about the problem. Well, the first thing you should do is one of the easiest. Pack up the scanner and get it ready to ship back to Regency in Indianapolis. Write a letter describing the problem you are having and then tell them you would like to have it corrected.

The problem is best described as a floating birdie. You know how you get "birdies," or scanner-generated noise, on your receiver on certain frequencies on most scanners. The HX-1200 sometimes has a problem in that the birdies float around from one frequency to another. One minute it could be on 460.050 and the next minute it might be on 33.08 MHz. We've heard Regency will correct the floating birdie problem in HX-1200 scanners if you return them to the factory and state that you are having such a problem. For more information, contact Regency at the address on your owner's manual.

Charles F. Bailey of Edgerton, WI poses an interesting question regarding why police and fire departments identify themselves by callsigns and designated unit numbers on the air, while businesses and farmers in his area never identify, making it difficult to determine who they are. I guess the easiest way to look at it is this: The emergency services are disciplined services. Though you may be a volunteer in a fire department or rescue squad, these disciplined services go by a procedure which dictates that you must answer to your chief or captain. If the chief tells his dispatcher to make sure the station's callsign is read over the air every 10 minutes, you don't dispute it, especially if you want to remain a member of the organization. In addition, most emergency services train their members in proper radio usage, which is very important in that their communications are monitored by many people with scanners.

Proper radio communications can make a real difference in an emergency situation. A dispatcher knows that if a chase is in progress, it really isn't necessary to come on the air and read the callsign. It might interfere with officers involved in the chase. On the other hand, businesses and farmers have no

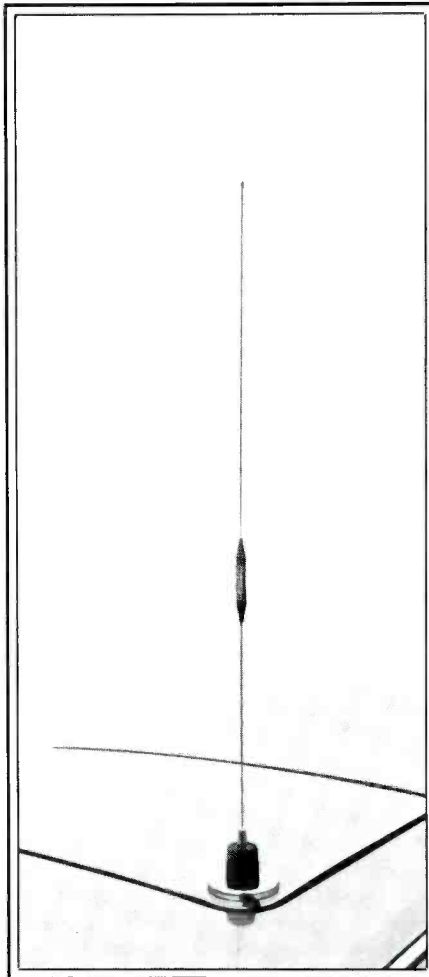

The Regency Informant MA-547 magnet-mount scanner antenna covers VHF low and high bands and UHF. It also is available in a mirror-mount version for truckers. The antenna is less than 30 inches tall.

need for formal communications. If Farmer Jones wants his hired hand to bring the tractor around to the cornfield, that's all he has to say: "Hey, Bob, bring the Deere over to the east side." Most farmers and business people know little of the FCC rules requiring the use of callsigns. Whether they are delivery truck drivers, garbage collection services or lumber yards, they just pick up the mic and call, "Unit 103 to Unit 102, open the gate." There is little radio discipline at most businesses. There are exceptions to the rule, however. For instance, at the newspaper where I work, the newsroom and photographers use the newspaper's callsign on their radios, however, the circulation and advertising departments do not.

So, you'll hear the callsign in the middle of the night, but not in the middle of the afternoon when papers are being delivered.

Warren Olson, a 14-year-old scanner enthusiast from Winnipeg, Manitoba, sends along some frequencies for the great northern city of Winnipeg:

413.225	Police Channel 1
413.125	Police Channel 2
413.9875	Police detectives
413.1625	Fire
413.3625	Ambulance dispatch
413.2875	Meter readers
155.460	RCMP
155.550	RCMP emergency

Richard D. Murray, KCA6NS, of Herlong, CA passes along a tip in finding the frequencies used by military convoys. Most Army, National Guard and Army Reserve "tactical" vehicles are equipped with radio transceivers operating between 30 and 52 MHz. The radios are capable of direct dialing of frequencies every 5 kHz, i.e., 36.05, 36.10, 36.15, etc. There is no standard set frequency for military operations, except for some fixed base stations. In an effort to increase communications security, frequencies are changed every day during military exercises. Richard also suggests low-band skip DX'ers keep an ear on 39.70, the frequency used by most military police stations in Germany.

Jerry Simon of Far Rockaway, NY, said that during a recent skywriting event over New York City and Nassau County, NY, 122.850 was used to coordinate the movement of aircraft, the writing of messages and also for the lead pilot to alert other pilots of air traffic in the area. Other suggested frequencies to keep an ear on are 122.750, 122.900 and 122.925 MHz. These are pilot-to-pilot frequencies.

Ed Steinbart of Port Richey, FL says his local sheriff's office is switching to the "8 meter" band and that he is interested in tricking his Bearcat 210XL into receiving these frequencies. The 8 meter band? It's been at least 50 years since the last time I heard VHF low band referred to as the 8 meter band! When the police department in Bayonne, NJ installed the first two-way police radio system 50 years ago, the 8 meter band was hailed as modern technology. Other police departments around the nation inquired as to how this new-fangled 8 meter band was working. And now, Ed's local sheriff's office is confusing every one by telling them they are moving to the 8 meter band. It sounds like someone in the sheriff's office down there is either a Ham or wants to drive the

scanner listeners bonkers. Ed, all you need to do to find these folks is to set your scanner on search between 30 and 50 MHz and wait for them to key up those 8 meter transmitters!

Every once in a while, I get a letter from a reader who says that they can't seem to find anyone else in their area interested in scanner listening. One 14-year-old boy said no one in his age group could give a hoot about 10-4, Code Red and MegaHertz. He complained that everyone else interested in the hobby was at least 20 years older than him. Having been there myself a moon or two ago, I can understand his dilemma. Either you hang around the static veterans or learn to repair go-carts. When I was in junior high school, I knew only a handful of others my age who were interested in shortwave, CB or scanners. And many of them didn't even go to my school. However, I decided to try and form my own club at school. I attracted mainly electronics buffs, but quickly found out there were others interested in radio like myself. Eventually, I started a regional club with another radio buff and we were handling public service events with our radio equipment—all during the tender teen years.

My point is that if you look, you'll find others interested in the same hobby. Don't expect them to come knocking on your on your door. You may have to go around the

neighborhood, knocking on doors yourself at homes with scanner antennas on their roofs, but there are other buffs out there. If you need to advertise the fact that you are starting a club, print up some fliers and place them in your local radio store. You also might want to place an ad in *POP'COMM*.

The great thing about having a local scanner club, or even an informal group of scanner listeners, is that you each can exchange frequency and code information. One member may have the 10 codes for the fire department, while another may have the unit numbering list for the police department. You'll never know, however, unless you try. If you get a scanner club going, let us know and we'll help you contact other scanner buffs in your area. If you're in a major metropolitan area, chances are there already is some type of scanner club in operation. Ask around and you'll find others to exchange information with.

We'd like to hear from you here at *Scanner Scene*. We welcome your comments, scanner tips, frequency lists and photographs. Let us know what you're listening to and what clubs you belong to. What do you like or dislike about your scanner club? Write to: Chuck Gysi, N2DUP, *Scanner Scene*, *Popular Communications*, 76 North Broadway, Hicksville, NY 11801-2909. **PC**

NEW! BOOKS FROM GILFER

MORE Radio Receivers, Chance or Choice



Sequel just
\$12.95
(+ \$2 UPS)

If you liked the original, you'll love the Rainer Lichte sequel! Another fact-filled book of reviews. **Not a computer printout** — a real book. 14 reviews in all. Grundig Satellit 400; 650; Icom R-7000, Kenwood R-5000, Panasonic RF-B60m, JRC NRD-525 and more — all new.

The Original "Radio Receiver, Chance or Choice," Plus "MORE Radio Receiver, Chance or Choice" — together 320 pp. All real-life specifications are exactly comparable between books. **Only \$19.95 + \$3.00 UPS**

Better Radio/TV Reception by Ashok Nalawalla

Non-technical explanation of radio/TV reception emphasizing shortwave. Explains Long Wave, Medium Wave, all types of antennas, satellites. Definitions from amplitude to zulu. Imported from Australia direct. **8½ x 11, 129 pp. \$14.95 + \$2.00 UPS**

Utility Address Book by Wilhelm Herbst

"139 pages of pure joy for (utility) DX fan" Pop'Comm Review says. Contains 3200 addresses around the world. Imported from West Germany direct. **6 x 9, 139 pp. \$12.95 + \$2.00 UPS**

GILFER SHORTWAVE

52 Park Ave., Park Ridge, NJ 07656
Phone Orders 201/391-7887 8 AM - 11 PM

SECRETS OF SUCCESSFUL QSLING

The Complete Guide To Reception Reporting and QSL Collecting, by Gerry L. Dexter gives you all the inside info you need to help you get a mailbox full of foreign mail! Foreword by Ian McFarland of Radio Canada International.

128 pages **\$9.95** plus \$1 shipping & handling

LANGUAGE LAB

Over 800 English sentences, phrases and words let you create an endless variety of reception reports in French and Spanish. **\$12.95** each, both for **\$23**, plus \$1 shipping and handling, each book.

UNO, DOS, CUATRO

A Guide to The Number Stations by "Havana Moon." New revelations about the numbers stations by the recognized expert. **\$13.95** plus \$1 shipping and handling.

MUZZLED MEDIA

How to get the news you're missing. A great intro to shortwave for the news junkie. **\$8.95** plus \$1 shipping and handling.

Foreign orders \$2 shipping and handling for surface delivery. US funds only.

More exciting titles on the way. Send \$1 for current list.

TIARE PUBLICATIONS

**P.O. Box 493
Lake Geneva, WI 53147**

PIRATES DEN

BY EDWARD TEACH

FOCUS ON FREE RADIO BROADCASTING

Many pirate operators are loners, individuals who have a go at unlicensed broadcasting for a time or two or three—acting as chief engineer and chief announcer. Some vanish forever, either of their own volition or because they got caught. Others, however, are really groups of people who have put some thought, planning, coordination and organization into the effort. One of these is **The U-A Group**.

"Gabriel Marconi" is the U-A Group's chief engineer and he describes the organization as a "small band of radio phreaks" (which is a freaky way to spell it) "and other misfits who have a common goal: to further the cause of free radio by producing and transmitting the best in alternative programming available." Gabriel says U-A has an advantage in that they have access to several state-of-the-art production facilities. The current group is not the first to use that overall name. An earlier U-A group was responsible for test broadcasts by such stations as the UA Express, Radio Lymph Node International and Shockwave.

According to Gabriel, U-A's latest project is a new station, **KSWL**, which may have already gone on the air by the time you read this. KSWL is "The Flagship of the Pirate Fleet" and will use a modified 5-kW AM transmitter which will operate between 1606 and 1635 kHz. A modified Collins 1-kW transmitter will be used on shortwave. Three homebrew portable transmitters are also available (one of which can also broadcast between 1606 and 1635). The station's equipment has the ability to cover 2 to 30 MHz but the shortwave operations will probably show up between 6200-6300 as well as on the 41 meter band, which Gabriel calls "pirate's alley."

KSWL says they believe their services will be needed someday by survivalists and other such groups. The station notes that its facilities are available to relay other sources of alternative programming. Gabriel noted that KSWL would probably be heard well before information got into this column so that would have put on an on-the-air target date sometime in late spring. If U-A adheres to their plans, this will be a station to be on the lookout for.

Another new station, though one with a more limited range, is **New World Radio** (NWR) which operates with "about 10 watts of power from a town in the mid-western USA." NWR says it uses a crystal-controlled frequency in the upper end of the FM band and has been operating since last December. Broadcasts normally take place on the

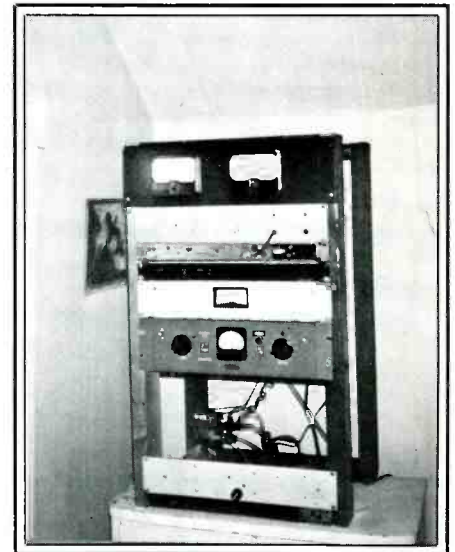
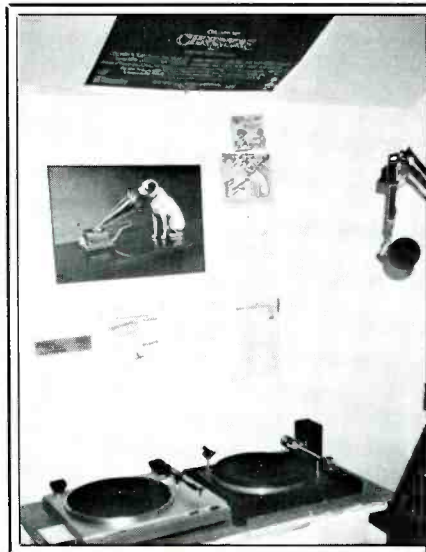
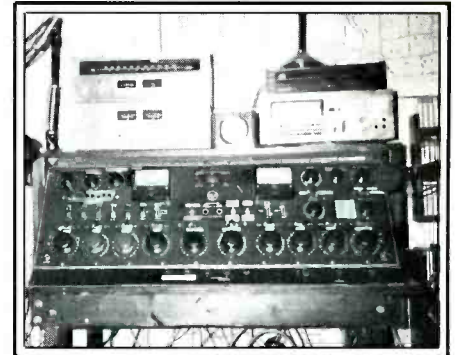

Various views of the equipment setup at New World Radio.

weekends from 10 or 11 p.m. to 1 or 2 a.m. local time, two or three times per month.

NWR says it "takes great care to see that we sound as professional as possible." A rebuilt RCA console, now adapted for stereo, along with a cassette deck and even a compact disc player make up some of the equipment in the photos featured this month. From the pictures and descriptions that the station provided it seems a good deal of used broadcasting equipment has been put into use at NWR in both studio and transmitting applications. NWR is having QSL's prepared and will later announce an address to which reception reports may be sent. Unfortunately for pirate chasers, the station—with 10 watts on FM—isn't likely to be heard much more than 20 miles away.

NWR also included a copy of a story by David Hughes in *Radio World*, a broadcast-

er's publication, headlined "FCC Battling Pirate Stations." The article quotes FCC sources as saying that the pirates who get caught are just the tip of the iceberg. The vast majority of pirates operate with such low power and so sporadically that they are difficult to catch. Jeff Young, an FCC engineer in the Enforcement Division, says most turn out to be "frustrated DJ's or college students who want to get on the air and run their own station."

Young said that the Commission catches only about 20 pirates in a year, a figure which is estimated to be only a fraction of the total. Public complaints about pirates are relatively few and are generated mostly when a pirate interferes with a legitimate broadcaster. Broadcasters will complain if a pirate begins to sound too professional or starts selling advertising. The FCC, Young

said, is particularly tough on pirates who interfere with public safety services. He predicts a growth in TV pirates, thanks to VCR's and devices which can relay a VCR's signal through a household. These can be modified and turned into mini-TV transmitted, according to Young.

Bruce Quinn, whose **Jolly Roger Radio** was one of the first of the modern day pirates, is still trying to go legit. Over recent years he has tried all manner of creative approaches to get FCC rules changed so as to allow a new path to get into broadcasting. Now, finally, he has been notified that an application he filed for a "community" FM station in Delphi, Indiana has been accepted for filing by the FCC. Good luck, Bruce!

Pirate activity in the shortwave bands has dropped off in the past couple of months. One station which was heard with tests is **Radio X**. It was found by David R. Brown in Texas and Mike Jandro of Minnesota around 0200 with very strong signals and an address announced as Box 110, Johnson City, NY 13790. Frequency was 7415. Mention was made of "Radio X testing to the world."

Let's get those receivers fired up and start prowling the pirate bands. Then let me know what you log. Also wanted are "station stories" from pirate operators—data on your setups, plans, parts and what-have-you, along with station photos. Sample QSL's, clippings about pirate news and such are also sought. Be sure you check in whenever you have something of interest! **PC**

They're Here!

MODERN ELECTRONICS

FUN PROJECT BOOKS

You'll want these two exciting project books, packed with complete plans for building a wide variety of useful electronic devices. The *First and Second Books of Modern Electronics Fun Projects*, both Howard W. Sams publications, are now available.

You'll find all the how-it-works information, schematics, photos, drawings, printed-circuit guides and parts sources to make it a snap to build almost 50 useful, unique electronic devices at modest cost.

Discover how these circuits and modern electronic devices perform their magic. Learn practical electronic technology the painless way and have fun doing it!

All projects are based on material published in *Modern Electronics*, with updates and revisions. They've been built and tested by the original authors. Chapters are divided into Intro To Electronic Projects, Home Electronics, Audio/Video Electronics, Security Electronics, Computers, Test Equipment, and Electronic Designing. There's something for everyone!

Look at what you can build & take pride in:

- *Digital voltmeter accessories—high-frequency ac probe, true-rms adapter, temperature probe
- *Car projects—anti-theft alarms, engine tachometer
- *Life-saving detectors—gases & microwave leaks



- *Computer system power controller
- *Dual-pulse generator
- *Surround-sound audio enhancer
- *Security—telephoned status reporter, alarm control center
- *Home convenience—selectable phone ringer musical tunes, touch-sensitive light controller.
- ... and so much more.

The Fun Projects are capped by introductory information on building projects and kits (tools needed, parts sources, etc.) and advanced design techniques that illustrate how a designer thinks and plans when putting together a practical end product.

From beginning to end, MODERN ELECTRONICS FUN PROJECT BOOKS are for you! Order them today for a fast start in the world of electronics.

RADIO WEST

SHORTWAVE RECEIVER MODIFICATIONS

SOUND'S GOOD? LET RADIO WEST MAKE IT SOUND EVEN BETTER WITH OUR RECEIVER MODIFICATIONS AND ACCESSORIES!

ESKAB PLAM MODS for ICOM R-71A & 70,	\$165
NRD 525 AND 515 models	\$165 to \$225
SUPER CERAMIC FILTER MODS 4 khz instl.	\$50
KOKUSAI MECH. FILTER MODS 2.4 khz	\$99
COLLINS MECH. FILTER MODS assorted	\$225
SONY 2010 FILTER MODS 2.7 khz filter instl.	\$35

Call for Other MODS and Prices

850 ANNS WAY

VISTA, CALIFORNIA 92083

(818) 726-3910

Free Price List 50¢ Postage.
New Catalog \$1.00.

"Sell around the world with RADIO WEST!"

CIRCLE 92 ON READER SERVICE CARD

Signal Intensifier \$29.⁹⁵

(ADD \$3 S/H)
(NYS ADD 7.5% TAX)

A HEARING AID FOR YOUR RECEIVER OR SCANNER!

- : Hear ALL the action with your receiver!
- : Make small antennas perform like BIG ones!
- : The State of the Art in WIDEBAND preamps!
- : Make those distant stations seem nearby!



BUILT TO LAST!
FULLY ASSEMBLED!
110 VAC POWERED!
MADE IN THE USA!

RFA-16B 30MHz - 1000MHz
VHF Low/VHF Hi/UHF/FM Broad
TV/Aviation/Cellular Telephone
*F Connectors standard. 15 DB gain!

RFA-20 300kHz-50MHz
SW/AM Broadcast/Marine/Ham
CB/MF/HF 15 DB gain!
*SO 239° Connectors standard.



ELECTRON PROCESSING INCORPORATED
P.O. BOX 708
MEDFORD, NY 11763 (516) 764-9798
ADD \$3 S/H NY ADD 7.5% TAX CHECK / COD

CIRCLE 114 ON READER SERVICE CARD

THE MONITORING MAGAZINE

MODERN ELECTRONICS

76 N. Broadway, Hicksville, NY 11801

Order Date: _____

Name _____

Address _____

City _____

State _____ Zip _____

() Check () MasterCard () VISA

Card No. _____

Expires _____

Signature _____

(Signature required on all charge orders)

QTY	Title	Price	Total
	First Book of Modern Electronics Fun Projects	\$12.95 ea.	
	Second Book of Modern Electronics Fun Projects	\$12.95 ea.	
		Total	
		*Shipping	
		Grand Total	

*Shipping charges \$2 per order. Orders processed day received, but please allow 30 days for delivery.

27 MHz COMMUNICATIONS ACTIVITIES

Goodbye, Goodbuddies

Ten years ago the area around 27 MHz sounded like a cross between a whistling contest and the funny farm. Howling heterodynes on almost every channel whistled so loudly there were times that communications were limited to short distances. Even so, when you could hear anything, all too often it consisted of little more than a contrived mish-mash of idiotic so-called "truckers' lingo," sprinkled with words like "negatory," "bodacious," "radidio," and worse. The millions of operators who were tightly wedged into the available channel space liked to refer to themselves as the "goodbuddies."

Even though CB had been around right from the start of the 1960's, it wasn't until the mid-1970's that it caught on with the public and turned into a grotesque parody of a communications service. Spurred on by CB-oriented hit records and several movies about CB'ing truckers, it seemed that almost everybody wanted to get on the air and talk "like that"—doctors, office workers, mechanics, lawyers, farmers, military types, deli owners, *everybody!* Put a microphone into the paws of even the most stuffy college professor and within seconds he sounded like what Hollywood and Nashville thought how interstate truckers sounded. It was amazing!

Not only was it amazing, it was fun, even though nobody ever explained why anybody would want to go out of their way to speak like that when communications could just as easily be exchanged using more conventional techniques. Some who disdained all of these shenanigans quietly moved away from the AM mode stomping grounds for such activities, and into SSB operation. On the frequencies where SSB operators hung out, you didn't hear any clever CB "handles," and anybody daring to use 10-codes or truckers' lingo was immediately ostracized as a pariah.

Although several factors contributed to the decline of the "Goodbuddy Empire," the fact was that after a few years of sheer pandemonium on the CB channels, the fun had worn thin and the novelty had totally worn out. The Sidebanders (as they have always called themselves) remained in place. The CB'ers (as AM-mode operators were known) drifted off to parts unknown, leaving their channels in a state of shock. After 1979 the channels began to take on an ominous silence. A shame, too, because a really great idea for a personal communications service seemed to have burned itself out.



Midland International's "System EZ-2" is a complete 40-channel CB mobile station in one package. Everything from soup-to-nuts comes included for \$149.95. This clever idea is one of the new directions CB is taking as 27 MHz bids a fond farewell to the "Goodbuddies" and heads towards the 1990's.

Happily, the 27 MHz band is making a startling comeback. Starting in about 1985, a bold influx of new operators began to appear on the CB channels. For the most part, the new breed of CB operators sought no identity ties with the goodbuddies of the 1970's. As pointed out by John Chass, a marketing executive at Midland International (a leading CB equipment manufacturer), "The CB buyer who led the boom 10 years ago was characterized by a medium income, trucker or frequent over-the-road professional who purchased CB as a two-way communications device."

Chass' market research indicates that (in his words), "Today, while the blue collar

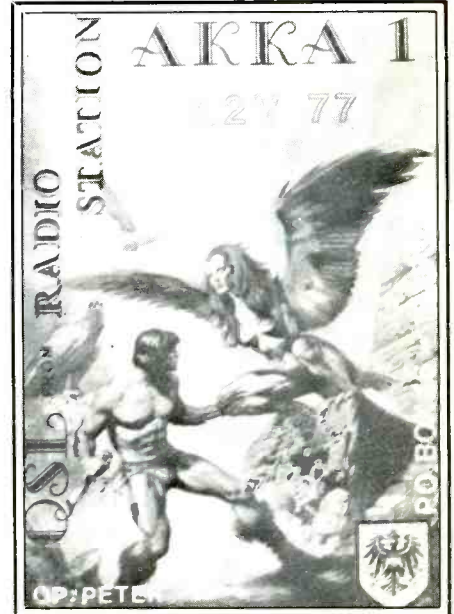

Peter, known as "AKKA 1" and "A2V77" on 27 MHz, hails from Austria. His QSL is from the realms of science fiction fantasy.

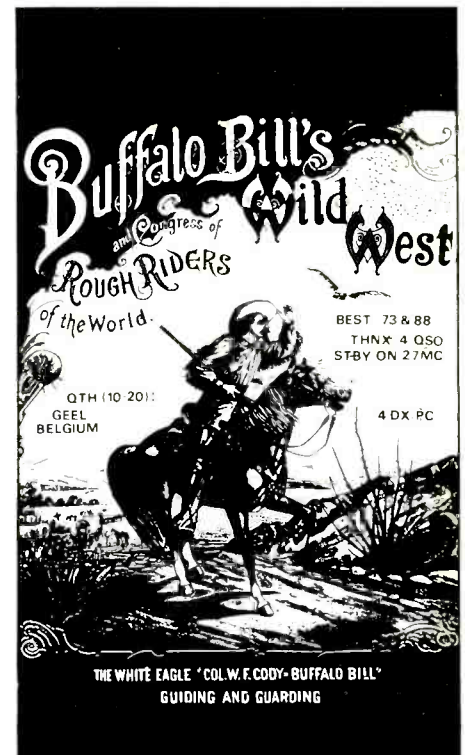

America's Old West was the inspiration for the design of this QSL from a 27 MHz operator in Belgium.

worker remains an integral part of the market, the majority of sales have shifted to the upper income professional or managerial white collar worker . . . 60% of today's CB radios are bought by first-time buyers." These are people who have realized the potentials of CB for use in highway emergencies, low-cost business and maritime communications, and various public safety applications such as "Neighborhood Watch" and similar programs.

And why not? CB equipment is simple to use, inexpensive, and needs no FCC license. FCC regulations regarding its use have been liberalized to the point where, so long as you don't run overpower or off-frequency, you're allowed to do virtually anything you want with the equipment except use it to aid in the commission of a felony or to "shoot skip" (work DX).

Currently made 27 MHz equipment leans heavily towards appealing to the new breed of user. Some CB transceivers are conveniently offered as a total package, with everything you need blister-packed to a single board—transceiver, microphone, antenna system, mounting hardware, etc. And while some equipment is very basic in what it offers, it's still possible to obtain rather sophisticated CB gear loaded with fancy features. Manufacturers including Radio Shack, Midland, Sparkomatic, Fanon-Courier, Cobra, Uniden, Fox, Whistler, and Pace are among the leading companies making quality 27 MHz transceivers. CB

base and mobile antennas are also available from some of these companies as well as Antenna Specialists, Butternut, and others.

In response to reader requests for POP'COMM to regularly report on the usefulness and safety applications of 27 MHz, proper operating procedures and practices, preferred channel usages, new equipment, tips and techniques, and CB activities in gener-

al, this section of the magazine has been created.

We seek your reactions, your station photos, local information, QSL's, thoughts, ideas, and suggestions. So many readers have asked for POP'COMM to include information on the rebirth of CB, that it did seem the time was right to do it now. Let's hear from you!

PC

Survivable Field Communications

SR-MP-25

HF SSB Para-Military Manpack Transceiver

- 25 Watt PEP High Power (Low Power 5 Watts)
- USB/LSB/AM/CW
- Synthesized
- Submersible To One Meter
- Internal Antenna Coupler
- Mobile Mount For 12 VDC
- AC Power Supply For 115/230 VAC
- Whisper Mode

Engineered for trouble free operation in any climate . . . desert, tropic, jungle and arctic!

SRS

Scientific Radio Systems, Inc.
367 Orchard Street, Rochester, N.Y. 14606, U.S.A.
Telephone 716-235-2040 • Telex 978-368
FAX 716-235-7827 • SIRAD ROC

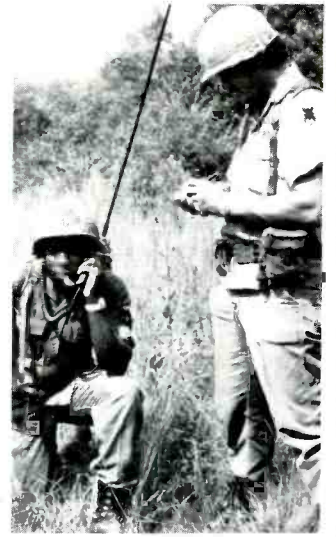

CIRCLE 86 ON READER SERVICE CARD



SALE PRICE \$34.95
Reg. \$44.95
M 8201 (G)
GOLD



KNOW THE TIME ANYWHERE, EVERYWHERE INSTANTLY

- 12/24 Hour Time Piece.
- Dual Dial World Time Clock.
- Easy to read local time in cities around the world.
- Daylight/Nighttime shown on 24-hr. dial
- Accuracy assured to ± 15 seconds per month with quartz movement.
- Time piece diameter 6 1/2"
- Uses 1 "AA" battery not included.
- Guaranteed for one year.

SALE PRICE \$37.95
Reg. \$49.95
M3111 (AJS)



• Gold or silver time piece. Randomly displayed in a smoked acrylic stand.

A UNIQUE GIFT ITEM.

ORDERS ONLY CALL 24HRS/7 DAYS
1-800-835-2246
Ext. 216

Florida residents add 5% sales tax. Within the Continental U.S.A. please add \$2.50 shipping and handling.

SALE PRICE \$64.95
Reg. \$79.95
M3202 (WIG)
WOOD/GOLD



WORLD-TECH PRODUCTS, INC.
1233 Kapp Dr. Clearwater FL 33575
(813) 442-5862





COD's Acceptable

SALE PRICE \$74.95
Reg. \$89.95
M3104L
LUCITE



CIRCLE 108 ON READER SERVICE CARD

MODERN ELECTRONICS

Now you can reach out every month and learn about the latest innovations in consumer electronics and personal computers—what's new, how products and circuits work, and what leading authorities think of them.

- *Stereo *Video *Home & Car Electronics
- *Test Instruments *Circuitry & Devices *Servicing
- *Personal Computers *Communications *Construction Projects

In every issue, authors lucidly explain how exciting, new electronics ideas are applied . . . issue forthright buying counsel . . . present complete plans to build electronic devices to enhance products, even unique ones that are not yet being sold in the marketplace.

Just fill out the coupon and mail with your check, money order, or credit card information (Visa or MasterCard) to enter your subscription. Do it today to ensure earliest delivery!

MODERN ELECTRONICS 76 North Broadway, Hicksville, NY 11801

Please send me Modern Electronics for 2 Years 1 Year

Name _____ 3 Years (36 issues) . . . \$48.00
Street _____ 2 Years (24 issues) . . . \$33.00
City _____ 1 Year (12 issues) . . . \$17.97
State _____ Zip _____

Charge My Order To: Payment Enclosed \$ _____

- MasterCard
 VISA

My account number is:

--	--	--	--	--	--	--	--	--	--	--	--



BROADCAST TOPIK

BY MARK MANUCY, W3GMG

DX, NEWS AND VIEWS OF AM AND FM BROADCASTING

Recently I spent a day and a half with a great group of broadcast engineers from across the U.S. and Canada talking about AM stereo. They're not a large group, but certainly a diverse bunch of guys that are all excited about AM radio. The Canadians were especially interesting to talk with since their government handles the broadcasting industry differently than does the FCC of the U.S. As a matter of fact, the Canadian government has approved the C-Quam system as the sole system to be used in Canada for AM stereo. To carry this a step further, according to scuttlebut and what I've been reading in the trade rags, it appears the FCC may have approved the C-Quam system for the U.S. by the time you read this. This would certainly allow the radio makers and the broadcast shakers to get on with AM stereo here in our country.

Here are a few things I thought might be interesting to you on this subject. Delta Electronics is one of several manufacturers of the C-Quam stereo system. They have an excellent product; we studied it from stem to stern. We used a CD player as an audio source to broadcast through a 35-year-old Gates 250-watt transmitter. For those who might remember the transmitter, it uses 810 tubes as modulators and in the final PA. An 813 is the PA driver and 6L6's drive the modulators. It's good to witness a grand old transmitter from another era seeing duty as a modern-day stereo demonstration transmitter! Delta had the cabinet all spiffy and shiney—as proud as the day it was new.

OH! How did it sound? Thought you'd never ask . . . Using a Carver receiver it sounded like FM, though I can't say better than FM, because even though Delta had modernized the audio feedback circuits in this granddaddy, it was a little short on the low end of the audio spectrum—probably down a couple of db around 100 Hz and below. We listened to several of the stereo stations around Washington on this Carver and had a ball comparing one with the other. An interesting side note about the Carver: when it was first turned on and we listened to a local station we kept hearing the infamous "platform motion," yet it was before noon and the station was close at hand. It turns out that Carver has a button on the receiver that simulates "platform motion" on any source, be it radio, tape or CD! And I thought that platform motion was undesirable!

Well, we looked at specs, the spectrum analyzer, the scope and other test equipment and concluded, after everyone had turned every control we could find on the stereo exciter, that here was a piece of gear that AM radio can truly be proud of. The

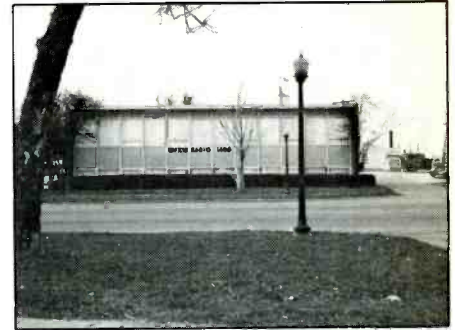

Here are a couple of photos of WFXW. The transmitter site is in St. Charles, IL, (left), while the studio is in Geneva, (right).

St. Charles
STC
Saints

WFXW
AM 1480

Supports STC Fighting Saints

specs out of this old transmitter were excellent. There was less than 1% distortion and frequency response which is very usable out to above 10 kHz. We tried the new pre-emphasis curve and the spectrum was actually cleaner than without it. By the way, the spectrum was well within FCC specs, regardless of the frequency of audio tones we used. There had been some discussion earlier about the C-Quam system not meeting this requirement. Delta says they are selling about two of these units a week (as of May) worldwide, so I expect AM stereo will start to become noticeable by the end of this year and into next year. I have a listing of AM stereo stations for \$2.50 postpaid. See the address at the end of the column.

The AM radio committee has approved a pre-emphasis curve to be implemented with AM radio on a voluntary basis. All new audio processing gear and stereo generators will no doubt have this new pre-emphasis circuit included. If the pre-emphasis is not abused by the powerhouse stations and others, then there should not be additional interference created by this boosting of the high frequencies. Actually, according to what I saw at Delta back in May, this pre-emphasis will actually reduce the splatter if every station were to implement it as quickly as possible.

Included with the pre-emphasis is a stop-band filter at 10 kHz similar to the 15 kHz



stop-band filter used with FM stations to prevent interference with the 19 kHz pilot frequency. I'm as skeptical as the next person about limiting the high frequency response to 10 kHz and trying to compete with FM using 15 kHz. However, in order to make the AM band sound better as a whole, I think this route is the best to take.

All AM stations using pre-emphasis to 10 kHz will sound much better than a limited number with a flat response to 15 kHz. It will be difficult to get around forced improving of the inexpensive radios and existing narrowband sets, therefore the pre-emphasis will vastly improve the sound of these on which stations currently broadcasting flat audio to 15 kHz do not sound good. The average AM radio has a response of about 3 to 4 kHz at best; a pre-emphasis from 1 to 10

Call Letter Changes

Location	Old	New
AM Stations		
Tucson, AZ	New	KJMM
San Diego, CA	KLZZ	KKLQ
Turlock, CA	KYES	KMIX
Aspen, CO	KSNO	KYTE
Grand Junction, CO	KIIO	KVEE
Greenfield, MA	WPOE	WGAM
St. Johns, MI	WLNZ	WWSJ
Mountain Grove, MO	KLRS	KRFI
Aztec, NM	KKBK	KCEM
Ruidoso, NM	KREE	KBUY
Plano, TX	KTNS	KSSA
Salt Lake City, UT	KBUG	KCPX
FM Stations		
Mountain Home, AR	New	KCMH
Pine Bluff, AR	KADL	KZLR
Desert Center, CA	KORS	KZAL
San Diego, CA	KLZZ-FM	KKLQ-FM
Santa Cruz, CA	KSCO-FM	KLRS
Turlock, CA	KMIX	KMIX-FM
Frisco, CO	New	KYSL
Miami, FL	WINZ-FM	WZTA
Kailua-Kona, HI	KHJM	KLUA
Kankakee, IL	WBSW	WBUS
Sebewaing, MI	New	WWMI
Boonville, NY	New	WBRV-FM
Philadelphia, PA	WTRK	WEGX
Westerly, RI	WERI-FM	WWRX
Amarillo, TX	WBUY-FM	KDJW-FM
Luling, TX	KCWR	WAPT
Park Falls, WI	New	WHBM-FM

PROFILE PROFILE PROFILE PROFILE PROFILE PROFILE PROFILE PROFILE PROFILE PROFILE

Bring Customers in to ALL Your Metro Store Locations

with Washington's Only
50,000 Watt AM/FM Combo

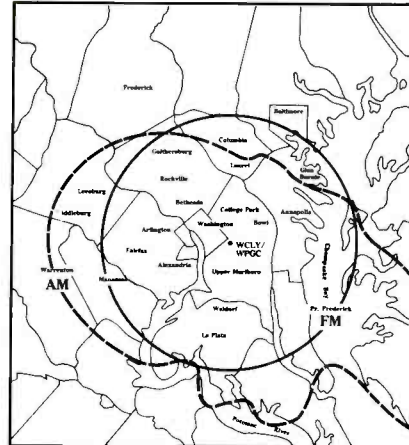

WCLY 95.5 FM
50,000 WATTS

WPGC 1580 AM
50,000 WATTS

WCLY FM



WPGC AM

Now that WPGC/WCLY has upgraded to 50 kilowatts, I can hear this old favorite of mine in Baltimore.

660
AM

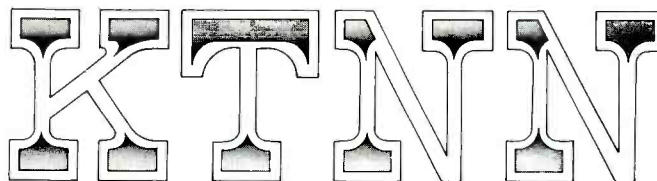

NAVAJO NATION - COUNTRY HITS

kHz reaching 10 db boost at 10 kHz will do a lot to improve the sound coming from the small tabletop radio and the inexpensive auto radios. The better quality radios such as the Carver and other wide-band receivers will have to either retro-fit de-emphasis circuits or settle for reducing to high frequency response by using the graphic equalizer or treble tone control.

In order to improve the quality of sound in the Vancouver, BC, area of Canada, the AM broadcasters have gone on the cable in the area. Some twelve or thirteen AM broadcasters are currently on the FM portion of the cable; many are broadcasting in stereo. In addition to other Canadian FM stations, there are eleven U.S. stations also on the cable.

Gary Bourgois writes to tell us the virtues of the now defunct Radio Shack AM stereo tuner which sold out at \$30. He sent a list of 15 AM stereo stations he listens to every night, plus some in the daytime. He's also

another owner of the ICF-2010 from Sony.

More reception reports of CJFT, Nashville and Champaign, IL. From St. Charles, IL comes a letter and photos from David Molinelli. A few months ago I mentioned the new Arizona station on 660 kHz, which was heard by a reader in California. Tony Haley sends me more info on the station. We mentioned that they broadcast in the Navajo language in the wee hours of the morning. In a letter to Tony, the General Manager, Delfred Smith, says the station is owned by the Navajo Tribe and that it is the most exciting, adventurous undertaking the Navajo Tribe has engaged in. This is the first American Indian-owned station and I think the concept should be applauded by all. KTNN is a 50-kW station on 660 kHz broadcasting from 5 a.m. to noon in the Navajo language and from noon to midnight in English. They have programming for the Navajo, Zuni Pueblo, Apache and Hopi Americans. I love their bumper sticker. The out-

line of the border and letters are a robin's egg blue, the background is yellow.

Another three-letter call bites the dust . . . WHN in New York will become WFAN when they switch their format to all sports. I never thought I'd see all three letter calls disappear before I did, but at the rate we're going it could happen—and I won't have to live a whole lot longer to see it! It's almost fingers and toes time for counting them now! WYNY (FM) may take over WHN's former country and western music format.

WFIL, 560 in Philadelphia, is rebuilding their antenna system and will be pulling their old 400-foot towers down to replace them with new ones. One of their engineers said they are going to literally pull down two with a crane while still transmitting on the third. After the two are replaced, the remaining one will be pulled down and replaced! They recently shut the Kahn stereo system off and are replacing it with C-Quam.

It was a privilege to tour WPGC/WCLY

recently; this is a long-time favorite station of mine in Washington. Benjamin Hill, the new manager, knew many of my old Florida cronies. The station is located on the top floor of a high-rise next to the beltway and DJ's can glance out the window and give traffic reports, but you should see the view of the Maryland country-side from Ben's office . . . wow! The AM station was recently upgraded to 50,000 watts; see the coverage map. The signal now travels way down through central Virginia and can now be heard in Baltimore. There sure is a BIG difference between ten and fifty kilowatts. They, too, will be adding C-Quam stereo before long.

All East Coast readers surely remember Music Radio-77, WABC, and their *Silver Dollar Survey*. Bill Weisinger sent me a photo copy of the March 1962 issue. The good guys must have had a strong influence on Bill as he is now teaching broadcasting in Cleveland. The brochure included pictures of Herb Oscar Anderson, Fred Hall, Charlie Greer, Sam Holman, Scott Muni, Dan Ingram and "Cousin Brucie" Morrow. That was twenty-five years ago, but lately there seems to be a small resurgence of that music, and earlier fifties music, on the AM band. This morning between 4 and 5 a.m. I was tuning around the dial, hearing a lot more music than I've heard in recent months from the big 50's. What do you think?

Well, that's about a wrap for the month. Send your news and views and photos to P.O. Box 5624, Baltimore, MD 21210. **PC**

Station Update

Call	Location	Freq	Pwr	Ant
AM				
KJOR	Reno, NV	550	1/0	NDA
WVOK	Birmingham, AL	690	50/.5	DA-N
KEWQ	Paradise, CA	930	1/1	DA-N
KBBK	Rupert, ID	970	2.5/.9	DA-N
WCNL	Newport, NH	1020	6.5/0	NDA
WCOK	Sparta, NC	1060	.8/0	NDA
WDGY	Minneapolis, MN	1130	50/30	DA-2
WWCA	E. Chicago, IN	1270	2.5/2.5	DA-1
WXRL	Lancaster, NY	1300	2.9/2.5	DA-2
WNRI	Woonsocket, RI	1380	2.5/0	NDA
FM				
WEAX	Angola, IN	88.3	1	144.3'
KVDP	Dry Prong, LA	89.1	3	207'
WOTL	Toledo, OH	90.3	1.15	360.4'
WGLU	Johnstown, PA	92.1	.3	1042'
WSBP	Saluda, SC	92.1	3	328'
KALP	Alpine, TX	92.7	3	268'
WRIT	Stuart, FL	92.7	3	328'
KMAZ	Beatrice, NE	92.9	100	810'
KQID-FM	Alexandria, LA	93.1	100	1521'
KEYV	Las Vegas, NV	93.1	24.3	3725'
WXLT	McComb, MS	94.1	100	980'
WFTN-FM	Franklin, NH	94.1	3	328'
KBSR-FM	Hardin, MT	95.3	95.4	984'
WATD-FM	Marsfield, MA	95.9	2.8	345'
WMVA-FM	Martinsville, VA	96.3	100	1282'
KGTN-FM	Georgetown, TX	96.5	28.5	653'
WCOZ	Paris, KY	96.7	1.45	469'
WSEK	Somerset, KY	96.7	3	328'
WKJX	Elizabeth City, NC	96.7	3	282'
KAVS	Mojave, CA	97.7	3	300'
WGGN	Castalia, OH	97.7	.64	725'
WTOO-FM	Bellafontaine, OH	98.3	1.41	466'
WJGS-FM	Houghton Lake, MI	98.5	100	981'
KTLC	Tye, TX	99.7	100	744'
WBRR	Bradford, PA	100.1	.970	534'
KTXF	Brownsville, TX	100.3	100	1351'
WHMA-FM	Anniston, AL	100.5	100	1142'
WUMF-FM	Farmington, ME	100.5	15.1	274'
WUSA-FM	Tampa, FL	100.7	100	599'
WOEZ-FM	Milton, PA	100.9	.64	690'
WYPC	Gallipolis, OH	101.5	50	492'
KVRE-FM	Santa Rosa, CA	101.7	.260	1115'
KNFT-FM	Bayard, NM	102.9	29.14	491'
KAYZ	El Dorado, AK	103.1	3	466'
WIBF-FM	Jenkintown, PA	103.9	.34	779'
WLWV	Salisbury, MD	105.5	2.1	385'
WJYY	Concord, NH	105.5	1.55	456'
KSLE	Seminole, OK	105.5	2.35	367'
WQSR	Catonsville, MD	105.7	50	492'
WSLT	Ocean City, NJ	106.3	3	310'
WOTB	Middletown, RI	107.1	3	328'
WSCP-FM	Pulaski, NY	107.1	2.5	364'

Key: D = Daytime, N = Nighttime, DA = Directional Antenna, DA1 = Same Pattern Day and Night, DA2 = Different Pattern/Power Day/Night, NDA = Omni Antenna Day and/or Night, * = Special Operation or Critical Hours, N/C = No Change.

SE SIGNAL ENGINEERING's High Performance CB Antennas

SUPERHAWK \$114.95

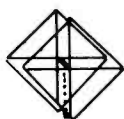

Goldenrod 45 Mobile Antenna



SPYDER A \$35.95

WHITE LIGHTNING \$199.95

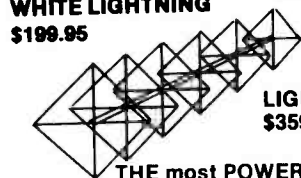

LIGHTNING 6 \$359.95

THE most POWERFUL
CB base in the world today!

All SE PATENTED rotary beams are true quads and OUTPERFORM their counter parts (quad/yagi types). SE's patented SFS matching system makes SE QUADS the most technologically advanced antennas in the world today.

If your dealer doesn't have SIGNAL ENGINEERING, write or call for full specs. DEALER inquiries invited.

SIGNAL ENGINEERING

2624 Fayette Drive, Mountain View, CA 94040
(415) 948-3833

Please send all reader inquiries directly.

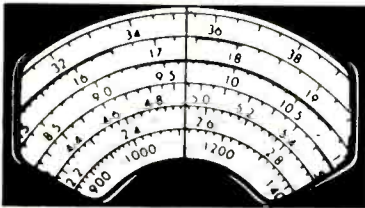

COMMUNICATIONS CONFIDENTIAL

BY DON SCHIMMEL

YOUR GUIDE TO SHORTWAVE "UTILITY" STATIONS

Many of you will perhaps recall the appeal for a receiver which I relayed from a New York lad, Don Pearce. I have just received a letter from Don and he asked me to please thank all the wonderful folks who contacted him with offers of assistance. Don informed me that he now has a working receiver and that he has found employment at the local library.

Colyn Brookes of South Africa wrote in asking about two beacons he has not been able to identify. My references show ASN to be located at Ascension (Auxillary AF-Wideawake) on 360 kHz but VRN is not listed. I wonder if what you heard was beacon VLN which is located at Valenca, Brazil on 335 kHz?

Colyn also asked if he could submit some loggings and, of course, the answer is yes. That is what this column is for, the intercepts made by readers. Lengthy lists are not required. If you just have a few loggings, by all means send them in. Please remember to place your name and state or country after each logging and allow space between items so they can be cut apart.

Another fine batch of loggings came in from Jeff Hall, WA plus a question regarding the "AW" beacon he heard just below Travel Information Station (TIS) KNEV390 which provides traffic advisory for I-5 outside of Seattle, WA. The beacon is located at Arlington (Municipal-Waton), WA and is run by the FAA with a power output of 25 watts.

Jeff also compiled a listing of some more jamming signals with his latest loggings appearing in Table 1. All jammers were MCW.

A hint received from Patrick O'Connor, NH suggested the following: "If anyone reports to ships or commercial aircraft, it isn't in bad taste to *politely* request a photo. I have quite a collection, ranging from pictures cut from magazine ads for airlines, to beautiful 8" x 10" color photos of U.S. Navy ships! Not every request will bring a photo, but if you report enough, you'll soon have quite a nice selection."

Patrick added, "It might also be noted that, before long, many ships will possess equipment to communicate via satellite, cutting down on the use of ship-to-shore HF radiotelephone. Now is the time to log and report those ships and shore stations."

The foregoing is a very valid point. Increasingly in the future, there will be less opportunities to obtain QSL's from many of those stations.



DEPARTMENT OF TRANSPORTATION
UNITED STATES COAST GUARD

16MAR87

From: Craig A. Johnson
USCG Communications Station
Box 17, Kodiak, AK 99619

To: Ronald Marshall

Subject: Signal Reception

Ron:

Glad to hear from you mate, nice to know there are a lot of you HAM folks out there listening to us and helping to keep tabs on whats going on out there on the radio waves.

The signal you heard was our preliminary announcement to our regularly scheduled high seas weather broadcast given on 6506.4khz. We use it to align our receivers and announce to the ship operators when we will be giving our broadcast.

I do not have a prepared QSL card for you, I prefer to answer each QSO request personally and affix our stamp to it. Keep your ears open and DIT DIT TO YA!

73's

Craig A. Johnson
Craig A. Johnson



Ronald Marshall, AZ describes himself as a "Full Spectrum Listener." His equipment covers the HF/VHF/UHF frequency bands. Here is a recent QSL letter he received.

Table 1

kHz	Time	Comments
6165	1619	"DN" over what sounds like Radio Beijing's Russian service.
9520	1740	"BF" (very loud) over RFE, spills into 9515 kHz.
9585	1820	"NU" over VOA USSR service via Ismaning, W. Germany.
9625	1830	"G1" (sweep type) over FRE/RL.
9715	1834	"KU" and "WQ" over DW USSR service.
9855	1648	"SK" (very strong) over poss Afghan clandestine.

EMPRESA
LINEAS MARITIMAS ARGENTINAS
 Sociedad Anónima
 (ELMA, S.A.)
 Corrientes 389 Tel. 22-8111-4861
 1043 BUENOS AIRES

Of. Telefónica ELMA - BAIREZ
 22317 ELMA-AR
 22339 ELMA-AR
 21007 ELMA-AR
 9103 ELMA-AR
 12458 ELMA-AR
 16459 ELMA-AR

Buenos Aires 8 de Abril de 1987

Señor
HUGH M HAWKINS

De mi consideración:

Por la presente acuso recibo de su carta del mes de Marzo pasado, en la que nos informa haber recibido señales de nuestra Estación Costera ISA.-

Asimismo confirmo que los datos reportados son correctos.-

Esta estación pertenece a la empresa naviera Lineas Maritimas Argentinas S.A., y tiene por objeto mantener las comunicaciones con los buques de la empresa.-

La potencia de emisión es de 3 KW utilizando una antena emisora logaritmica direccional en la frecuencia por Usted escuchada y Marconi convencional en el resto de las frecuencias.-

Al agradecer su atención, saludo a Usted con mi mayor consideración.-

 HUGO ROS
 E/A

An Argentine QSL received by Hugh Hawkins, TX.

US Department
 of Transportation
 United States
 Coast Guard

3/13/87

Dear Mr. Ross,

Thank you for your report of reception. Your information is correct. The broadcast that you heard was the Delores Marie case in which the ship did sink. A CG Helo was able to drop a life raft to the 3 persons in the water and they were eventually picked up by a CG Vessel.

I would also like to thank you for the stamps that you sent along. I receive requests for QSL cards from many countries and I collect the stamps. Yours are now added to my collection and the first from Canada.

Please write again if you have any questions or would like more information. Good listening to you.

Sincerely,

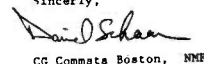
 CG Commata Boston, NMF



An interesting QSL submitted by Robert Ross, Ontario for a Mayday report he sent to the Coast Guard.

Another hint from Patrick was that if one logs Civil Air Patrol activity, it is possible to log all 50 states on SW UTE.

From England comes a letter from Mr. T. One of his favorite late night frequencies for monitoring is 5658 kHz, the Middle East

ATC frequency. In just 15 minutes between 2345 and 2400 UTC he intercepted the following transmissions: Khartoum passing info to Aden, who relays it to Air France 108. Aden passing info to Addis Ababa. Pam Am 073 working Bombay. Addis passing info

about Swissair 292 to Jeddah. Addis working Air France 479. Swissair 283 working Cairo. Aden working Muscat. Cairo working Luxembourg Airlines 181. Bombay working Kharachi. Kharachi working Bahrein. (Note: All the ground stations were easily

Ministry of Communication & Transport

Telecommunication Department

P. O. Box : 2633

DOHA - State of Qatar

Tel. : 327448

Telex : 4468 DH.

Cable : GENETEL DOHA

Ref. No. MCT/TD/23/QCS/GEN/822J

Date : 28th February 1987



وزارة المواصلات والنقل

إدارة المواصلات السلكية واللاسلكية

ص. ب. : ٢٦٣٣

الطاقة - دولة قطر

هاتف : ٣٢٧٤٤٨

تلكس : ٤٤٦٨ ده

برقية : جيتل الدوحة

إشارة رقم : _____

التاريخ : _____

Mr. Patrick O'Connor

USA.

Dear Sir,

Thank you for your reception report, which we are pleased to verify as follows:

Date : 19th December 1986
 Time : 2126 UTC
 Frequency : 8473.3 KHz
 Mode : A1A (CW)
 Power Output : 5 KW

Thanking you,

Yours faithfully,

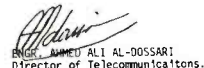
 ENCL. AHMED ALI AL-DOSSARI
 Director of Telecommunications.

Patrick O'Connor, NH shares with us two of the QSL's he received.

Abidjan, le 17 MARS 1987

AGENCE POUR LA SECURITE
DE LA NAVIGATION AERIENNE
EN AFRIQUE ET A MADAGASCAR

(ASBNA)

REPRESENTATION EN COTE D'IVOIRE

N° P 0431 / ASBNA/DIREC

OBJET : Confirmation d'écoute
du 25.01.87

REF : W/L du 25.01.87

Le Représentant de l'ASBNA
auprès de la République de Côte d'Ivoire

MONSIEUR PATRICK O'CONNOR

U. S. A.

Monsieur,

Suite à votre lettre sus-référée, nous vous confirmons votre réception de notre station le 25 Janvier 1987 sur la fréquence 8861 KHz.

Cette émission BUJ J3E assure H/24 la liaison radio, Air/sol d'une part et entre stations fixes d'autre part.

Nous vous prions de trouver ci-après quelques informations d'ordre technique qui, nous l'espérons, vous seront utiles.

STATION : ASBNA, Aéroport de Port-Bouët

INDICATIF : ABIDJAN

EMETTEUR : NARDEUX T160 Piloté par quartz

FREQUENCE : 8861 KHz

PUISSANCE : 6 KWatts en J3E

ANTENNE : BICOINQUE AIR/SOL

DIRECTION : OMNIDIRECTIONNELLE

HAUTEUR : 24 mètres

FONCTION : LIAISON AIR/SOL - SOL/SOL

Nous vous prions d'agréer, Monsieur, l'expression de nos salutations distinguées.



M. D. BANI ZAHRI

01 BP 1365 ABIDJAN 01 TELEPHONE 36-71-71



Marine Station Operations Mr. George Osier

Dear Sir: January 30, 1987

This is to confirm your reception of the WCC 8715KHz transmitter at 1641UTC on January 24, 1987.

ChathamRadio is a Marine Public Coast Station serving the communications needs of vessels in the Atlantic, Caribbean, Gulf of Mexico, and other waters east to the Indian Ocean.

Reception reports are appreciated.

Very truly yours,

W. H. Farris, Jr.
W. H. Farris, Jr.
Manager/WCC

Enclosure (1)

WHF:mc

CHATHAM RADIO CW TRANSMITTERS

FREQ. (MHZ)	POWER (KW)	ANTENNAS
436/500 (KHZ)	15	300 Vertical (80M.)
4.331	6	Folded Dipole
6.376	12	Dipole
8.586	10	Dipole
9.630	10	8 Halfwave Collinear
12.847	5	3 Element Yagi
12.9255	14	Dipole
13.0335	15	8 Halfwave Collinear
16.9332	10	8 Halfwave Collinear
16.972	10	Extended Zepp
22.518	10	8 Halfwave Collinear

CHATHAMRADIO SITOR TRANSMITTERS

4.3565	10	Halfwave Vertical
6.5045	10	Dipole
8.7125	10	3 Element Yagi
8.715	14	Dipole
13.0815	12	Full-Wave Loop
13.090	10	Dipole
17.2075	15	Dipole
17.216	10	8 Halfwave Collinear
22.5715	10	Dipole

QSL received by George Osier, NY with frequency and antenna information.

heard, unless Cairo was transmitting, when he swamped the lot with his powerful signal. Cairo also uses some kind of speech processing which makes it difficult to understand what they are saying, despite the strong signal.)

Mark Fosella, NY advises he finally determined the source of the strange signal on 4200 kHz he had previously reported to us. He traced the signal to the TV set belonging to his landlord!

Requests for sources of QSL addresses

continue to be received and I can now add one more reference title to those previously listed in the column. This new book, *Utility QSL Address Guide, Volume 1*, covers "The Americas." In addition to some 4500 QSL addresses, it also contains some extensive Utility Station callsign lists. *Volume II* will cover the rest of the world and is expected to be published later this year. The book can be obtained from CRB Research, P.O. Box 56, Commack, NY 11725. The cost is \$12.95 plus \$1 for mailing to North

American addresses.

Jock Elliott, NY thanked us for the tip on monitoring High Seas Radiotelephone channels. He tuned into one-half of a conversation where an individual was notifying his family that he was alright after having been on a private yacht near the Azores when a storm apparently swamped the yacht. He was rescued by a supertanker that was enroute to Spain.

Several readers have written in commenting on identifying certain Morse char-

Table 2

Freq	Opr/Lang	Mode	UTC	Comments/Text	Freq	Opr/Lang	Mode	UTC	Comments/Text
2707	YL/GG	AM	0614	4/5F	5414	YL/SS	AM	0700	5F
2806	YL/EE	USB	0623	5F	5420	YL/SS	AM	0550	5F
3060	YL/SS	AM	0545	No text	5692	YL/GG	AM	0620	3/2F
3090	YL/SS	AM	0405	5F	5812	YL/SS	AM	0223	4F
3150	YL/SS	AM	0502	5F	5846	YL/SS	AM	0706	5F
3225.7	YL/??	AM	0519	3F(?) Un-ID language	6225	YL/SS	AM	0712	5F
3437.1	YL/SS	AM	0525	5F	6768	YL/SS	AM	0723	5F
3445	YL/SS	AM	0435	5F	6778.6	YL/SS	AM	0611	5F
4307	YL/SS	AM	0315	4F	6875.6	YL/SS	AM	0705	5F
4443	YL/SS	AM	0522	5F	*6935.5	YL/EE	AM	1810	3/2F
4670	YL/SS	AM	0310	4F	6997	YL/GG	AM	0701	5F
4770	YL/GG	AM	0534	3/2F	8418	YL/SS	AM	0630	5F
5015	YL/GG	AM	0614	5F	9124	YL/SS	AM	0615	5F
5090	YL/EE	AM	0001	Callup of 303 303 303	18575	YL/GG	USB	1607	5F
5284	YL/GG	USB	0535	5F	19295	YL/GG	USB	1608	5F

*Simulcast on 6802

HAM RADIO IS FUN!

It's even more fun for beginners now that they can operate voice and link computers just as soon as they obtain their Novice class license. You can talk to hams all over the world when conditions permit, then switch to a repeater for local coverage, perhaps using a transceiver in your car or handheld unit.



Your passport to ham radio adventure is TUNE-IN THE WORLD WITH HAM RADIO. The book tells what you need to know in order to pass your Novice exam. Two cassettes teach the code quickly and easily.

Enclosed is my check or money order for \$15.00 or charge my

() VISA () Mastercard () Am. Express

Signature _____

Acct. No. _____

Good from _____ Expires _____

Name _____

Address _____

City _____ State _____ Zip _____

THE AMERICAN RADIO RELAY LEAGUE
225 MAIN ST.
NEWINGTON, CT 06111

CIRCLE 113 ON READER SERVICE CARD

acters as Soviet characters. I agree that perhaps this is not strictly correct and that they should be identified as Cyrillic Alphabet Morse characters, but it is common practice to call such special letters Soviet Morse characters.

An Associated Press item indicated that the Air Force believes the Ground Wave Emergency Network (GWEN) can be expanded "without significantly affecting the environment."

Public hearings were to be scheduled at various locations in the U.S. and even if the decision is to continue with the expansion, the Air Force is required to conduct individual impact studies for each selected tower site. The typical GWEN site has a 300-foot tower plus three small shelters. The shelters are for electronic equipment, emergency generator and fuel supplies. The normal site requires 700 square feet of land, each site being enclosed by a security fence. The full expansion calls for an additional 111 terminals at various military installations and building 70 more relay towers.

Rodney Wray, KY provided a rundown on an activity he had been copying but was unable to identify. The call signs were of the phonetic alphabet type. A check of my reference materials indicates these transmissions were those of the MOSSAD, the Israeli Intelligence Service. For additional details on this service see the article on page 35 of the July 1984 POP'COMM.

William Fernandez, MA devoted quite a bit of time to monitoring numbers stations and the list in Table 2 was prepared based on his loggings.

Abbreviations Used For Intercepts

AM	Amplitude Modulation mode
BC	Broadcast
CW	Morse Code mode
EE	English
GG	German
ID	Identifier/location
LSB	Lower Sideband mode
OM	Male operator
PP	Portuguese
SS	Spanish
tfc	Traffic
USB	Upper Sideband mode
w/	with
wx	Weather report/forecast
YL	Female operator
4F	4-figure coded groups (i.e. 5739)
5F	5-figure coded groups
5L	5-letter coded groups (i.e. IGRXJ)

Utility Station Intercepts (All Times Are UTC)

500: WSC, Tuckerton, NJ calling HBCL (Switzerland allocation) in CW w/tfc at 0307 (Malozzi, RI).
521: Beacon INE, Missoula, MT at 0641 (Kratzer, WA).

2025: USN MARS net in MO, NNN0XFN as NCS. USB mode at 0230 (A. Nonymous, MO-- heard while in IL).

212.5: W6K and 5P in comms about a medevac at Company C Barracks, USB at 0500 (Fernandez, MA).

2118: VXGB, ship MAHONE BAY at 0410 in USB w/kg St. John NB CG Radio (O'Connor, NH).

2166: NNTR, aircraft carrier USS THEODORE ROOSEVELT at 0500 in USB w/patches via WOO in NJ (O'Connor, NH).

2182: 8RB, Demerara, Guyana at 0534 in USB calling 4PCG, the ship CEYLAN WAVE (O'Connor, NH).

2398: Ship BOUDROW(?) reporting to Canadian CG sighting of a 100 X 40 ft. iceberg, USB at 0435 (Fernandez, MA).

2670: NOY, USCG Comsta Galveston, TX w/YL readinx wx in USB at 0302 (Ross, ONT).

2761: OSU, Ostende, Belgium in USB at 1846 w/info re salvage ops (A. Nonymous, England).

3026: F7N, un-ID station, in USB at 1846 working "Buchan" & reporting radar intercepts (Anonymous, England).

3151: CFX, Halifax Military, NS in USB at 0155-- an OM reading ex ("J.M.," KY).

3413: EIP, Shannon Aeradio, Ireland in USB at 0155 w/wx (Ross, ONT).

3469: 5L gps in CW at 0558 ("J.M.," KY).

3963: Missouri emergency & wx net w/statewide tornado drill. NCS was KODSQ; WAOFYA taking exercise tfc on 3977 kHz, all LSB (A. Nonymous, MO).

4063: Un-ID vessel reporting that another vessel near Barbados in distress. Comms shifted to 4357.5 kHz w/San Juan CG patched thru via WAH in the VI, USB 0655-0710 (Fernandez, MA).
4274: GKB6, Portishead, England in CW at 0311 w/marker (Vandervender, IN).

4357.4: WAH, St. Thomas, VI in USB at 0210 w/YL reading regional wx (Ross, ONT).

4376: Y5DB & other similar calls, all un-ID, in USB at 0707. Lists of #'s in GG plus some international phonetics (Fernandez, MA).

4400.8: NMA, USCG Comsta Miami, FL to USCGC SWEETCOMB in USB at 0920 re setting up RTTY comms on 4243 kHz. After RTTY comms established, USB continued on 4400.8 (Fernandez, MA).

4420: C7H to D8E in USB at 0646 w/lengthy comms re equipment problems (Kratzer, WA).

4470.5: NNN0AKF, USN MARS training net in USB at 2113 (Symington, OH).

4550: British Columbia net includes W. Richter, Comox Post, Port Alberni. In USB at 0010 w/tfc re the following day's assignments, air skeds for floatplanes, advisors, etc. (Hall, WA).

4580: KNKR783 ("Golden Pirate") IN state CD net in USB 2020-2200 w/disaster drill. Stations included North Command, Central Command, South Command, Shelbyville, Terre Haute, Ft. Wayne, Anderson & K2. For purposes of this mock disaster, the town of Jasper was in need of help (Symington, OH).

4582: KAF361 ("Bluebird 330"), MO CAP Wing net in USB at 2045 w/search sector coordinates being sent (Symington, OH).

4616: IDR2, Rome, Italy in CW at 0509 w/VVV marker ("J.M.," KY).

4625: An AM carrier w/beeping every 2 1/2 seconds, at 0550 (Fernandez, MA).

4742: Un-ID sta w/wx info to un-ID aircraft. This followed by a bc similar to USAF's Skyking xmsns, but using colors instead of phonetics. ID was "Donkey Tail," sounded British. Intercept at 0529-0534 (Fernandez, MA).

4721.2: Mil net in USB at 2014 w/radio checks for Baxcor, Shortstop & Strawberry (Stinnett, WV).

4770: YL in AM mode at 1414 w/mixed EE & CC 3F & 4F groups. Live, not computer generated, at 1418. Ended w/"Finish" (Hall)

5068: Un-ID Cuban station in CW at 0710 w/tfc in 8F gps, then into continuous V's (Hall).

5320: Key West Light Station in USB at 1320 to USCG Group Key West re beacon problems (Symington, OH).

5574: KMA7, San Francisco Aeradio, CA to United 120 in USB at 0237 (Szalony, CA).

5696: Rescue 'copter 1418 in USB at 0415 to Portsmouth, VA Comsta that all 4 crew members have been hoisted off trawler in distress. Location 175 ENE Portsmouth. At 1525 rescue 'copters 1472 & 1473 searching for vessel on fire 175 miles S of Block Island, MA. Vessel located & injured person taken on 'copter w/other persons taken aboard o USCGC. The CG put a crew aboard burning boat to extinguish fire & use pumps (Fernandez, MA).

5932: Canadian fishing net in USB at 1600 w/airborne op tracking "spawns" for other vessel ops over Pt. Langford, Hornby Island. Salmon tracking done by spotting sea lions & birds (Hall, WA).

6090: Outlanders?? In USB at 2318, smack in the SWBC band here. OM in EE in duplex w/tfc to un-ID station re test of "recording" system & sending tape repeat of things like chair noise in shack, etc. (Hall, WA).

6212.4: USCGC TAMAROA to Comsta Boston in USB at 1540. On scene of sinking Soviet vessel (Symington, OH).

6343: UKA, Vladivostok, USSR in CW calling CQ at 1402 (Szalony, CA).

6416: 7TA6, Algiers, Algeria calling CQ in CW at 0547 ("J.M.," KY).

6468: X34 asking B38 to move CP location 100 yards left of airstrip. Un-ID stations in USB at 1825 ("J.M.," KY).

6521.6: Fishing vessel w/callsign Y4CG to un-ID coast sta & vessel MAYFLOWER in USB at 1527 re crew changes, wx reports & fishing condx (Stinnett, WV).

6723: Continuous recorded test count, no ID, in USB at 1630. Possible USN as this is one of their aero frags ("J.M.," KY).

6800: YL/EE rpts 121 three times then counts 1-0 at 0203, AM mode, then suddenly a YL/SS begins 5F t/c on freq, but the EE station was stronger (Scalzo, PQ).

6805.1: YL/SS in USB at 0302 w/5F gps. During this, 2 OM/SS could be heard talking in background (Stinnett, WV).

6843: YL/EE in AM at 2205 w/5F gps (Scalzo, PQ)

6875.5: YL/EE in USB at 2316 w/5F gps (A. Nonymous, England).

6918: YL/EE in AM at 0545. The YL had an odd accent. Sends 5F gps, repeating each X2, ends w/907 907 126 126 0000 (Hall, WA).

7348: WGY920 Base, FEMA Boise, ID wkg WGY910, FEMA Bothell, WA & on op who ID'd only as "Portable." Talk of establishing nets. This intercepted on day of mock nuke attack in which WA State declined to participate. Also intercepted using 5821 kHz, Channel 17 of FEMA comms system (Hall, WA).

7410: YL in un-ID oriental language w/5F gps in AM mode, 0400 (Rogers, PA).

7485: NAYH, USS HARLAND COUNTY LST-1196 testing to Charleston Test Control in various modes including USB, LSB, AM, CW & RTTY at 1455 ("J.M.," KY).

8160: HIS, un-ID in CW at 1503 w/5L gps ("J.M.," KY).

8241.5: GZIS, HMS LIVERPOOL in USB at 2156 calling Portishead Radio (A. Nonymous, MO).

8244.6: H3ZS, ship SOO YANG #1 in USB at 2052 to DAJ w/patch at 2052 (O'Connor, NH).

8291.1: KWS637, Raytheon Company, Newport RI in USB at 1417 to BAY QUEEN (O'Connor, NH).

8293: Several JJ language stas in USB at 0337 (Linville, ALTA).

8411.9: YL/SS in AM mode at 0810 w/4F gps. After bc, carrier remained on to 0825 (Stinnett, WV).

8417: International Ice Patrol in CW at 0036 w/wx & ice reports (Stinnett, WV).

8471: 7RQ2/3/4/5, Algiers in CW at 2350 calling CQ (A. Nonymous, England).

8506: TAH, Istanbul, Turkey calling CQ in CW at 2310 (A. Nonymous, England).

8597: VIP, Perth, Australia in CW at 2245 w/VVV marker (Ross, ONT).

8688: 9VG36, Singapore in CW calling CQ at 2020 (A. Nonymous, England).

8766.3: NMN, USCG Comsta Portsmouth, VA in USB at 0530 w/maritime wx, notices to mariners, etc. (Kratzer, WA).

8861: Venezuelan Air Force 5320 in USB at 2112 wkg Recife Aeradio, Brazil w/position report (O'Connor, OH).

8984.4: USCG Comsta Kodiak, AK to aircraft 1708 at 0523 re shifting freq to 5000 kHz (Kratzer, WA) We presume in order to talk to WWV-- Ed.

8989: McClellan AFB to King 53 in USB at 2026 w/ETA info (Kratzer, WA).

8997: YL w/ID "South Pole" in USB at 0700 exchanging flite data with several aircraft (Fernandez, MA).

9023: Canadian NORAD exercise w/Brewmaster wkg Brewmaster Remote who reported dropping out of net for "demo for VIP's here." Other stations included D-Tone Golf & Focus Golf in net w/Conus Rock. Focus Golf turned up later on 8989 working McClellan AFB for patch t/c to Bush Ops & scrambled t/c. Focus Golf seems to be AWACS or an airborne CP. Heard on USB at 1916 (Hall, WA). These activities sometimes reported on UHF 228.7, 281.2 & other freqs-- Ed.

9027: USAF SAC, 2 Skyking bc's at same time, one by OM the other by YL, both w/usual beep tones at end, USB at 0206 (Fernandez, MA).

9121: YL/EE in USB at 2105 w/5F gps in an SS accent (Symington, OH).

10982.7: Un-ID aircraft xmsn at 0150 in USB w/pilots discussing air drops & mechanic info re Hercules aircraft (Stinnett, WV).

11239: RAF aircraft Ascot 2430 in USB at 2009 wkg McClellan AFB for patch to Fairchild & McChord metros. Pos report placed it inbound from over the Pole (Hall, WA).

11288: Possible anti-smuggler activities. Usually busy 1400-0300 weekdays, but quiet on days of poor wx in Caribbean. Stas seem to include tracker aircraft, interceptors, 'copters, cutters. All ops coordinated thru an AFB in FL using "Slingshot" as an ID. USB mode (Fernandez, MA). According to the new 6th Edition of Kneitel's "Top Secret" Registry, this is channel "Yankee Delta;" "Slingshot" is the aircraft coordinating center in Miami, FL-- Ed.

11631: K4Q, un-ID sta w/5L gps in CW at 1937. This sta previously intercepted on 5438 kHz. T/c ends w/BT AR then 5 mins of silence until resumes. During interval heard tone, 30 sec data xmsn (twice), a final tone then back to CW. Same procedure w/stas on 3262, 4445, 5438 & 8160 kHz ("J.M.," KY).

12429: The yachting crowd, apparently off

the Panama coast in the simplex net of KHY, Marina del Mar, CA. Some un-ID yacht club in USA to WHL2445, yacht DRACONA while Newport works other yachts. Seems to be pre-race warmup. USB at 0000 (Hall, WA).

12664.5: FUM, Papeete, Tahiti running a VVV marker in CW at 0055 (Ross, ONT).

12714: CBV, Valparaiso, Chile calling CQ in CQ at 0157 (Ross, ONT).

12795.2: PWZ33, Rio de Janeiro, Brazil in CW at 0157 w/VVV marker (Ross, ONT).

12950: UFB, Odessa, USSR sending CW t/c list at 1603 (A. Nonymous, England).

12980: UPB, Providentia Bukhta, USSR in CW sending CQ at various speeds (Hall, WA).

13008: JOR, Nagasaki, Japan in CW calling CQ at 0208 (Ross, ONT).

13024: HEB, Berne, Switzerland w/CW t/c at 1908 ("J.M.," KY)

13069.5: JOS, Nagasaki, Japan in CW at 0210 w/CW call (Ross, ONT).

13247: SAM 86970 in LSB at 1804 wkg Andrews for patch to Embassy Marine Guard at un-ID location (Symington, OH).

14462: 5F gps in CW at 1855, zeros cut as letter T, running at 33 wpm (O'Connor)

15044: RID, Irkutsk, USSR time sta at 0155 w/gud sigs (Rogers, PA).

15077: Sword 5 in USB at 1727 wkg Sword 1 w/on-site wx & clearances, plus description of "the range." Says "it's a go." Sounded like a USN missile firing range net (Hall, WA).

16868.5: 9VG53, Singapore in CW at 1420 calling CQ (A. Nonymous, England).

17151: NMC, USCG San Francisco, CA w/wx in CW at 1924 ("J.M.," KY).

17174.3: CLS, Fishing Fleet Headquarters, Havana, Cuba calling CQ in CW at 1709 (A. Nonymous, MO).

17215: GKP6, Portishead, England in CW at 1757 w/call marker ("J.M.," KY).

17495: Paris, France radio control center of the French Telecommunications Network-- a test xmsn for circuit adjustment purposes. A recorded annt by a YL in EE & FF, USB at 1844 (Scalzo, PQ).

18521.5: Un-ID CW sta sending random letters slowly (A. Nonymous, England).

20564.4: Several OM's at an un-ID astronomical observatory in coms w/another sta (unheard), LSB at 1810. Other station was in Johannesberg, RSA. La Cerena was mentioned as being near the mountaintop site of the observatory & having a local time that was EST -2 hours. Comms were informal & dealt mostly w/the observatory & local wx (Fernandez, MA).

PC

NEW 20-PAGE CATALOG FREE

7 MILLION TUBES

Includes all current, obsolete, antique, hard-to-find receiving, transmitting, industrial, radio/TV types. **LOWEST PRICES.** Major brands in stock.

Unity Electronics Dept. P
P.O. Box 213, Elizabeth, N.J. 07206



CIRCLE 112 ON READER SERVICE CARD

Free Catalog Features
Hard-To-Find Electronic Tools

Page after page of hard-to-find electronic tools and test equipment. Also contains a complete line of tool kits and tool cases. Send for your **free copy** today!



CIRCLE 111 ON READER SERVICE CARD



The magazine for Computerist & Amateur Radio
Your #1 source of Packet info.

... received my moneys worth with just one issue ...
—J. Trenbick

... always stop to read CTM, even though most other magazines I receive (and write for) only get cursory examination ...
—Fred Blechman, K6UGT

U.S.A. \$18.00 for 1 year

Mexico, Canada \$32.00
Foreign \$43.00 (land) \$68.00 (air)
(U.S. funds only)

Permanent (U.S. Subscription) \$150.00
Sample Copy \$3.50

CHET LAMBERT, W4WDR
1704 Sam Drive • Birmingham, AL 35235
(205) 854-0271

CIRCLE 10 ON READER SERVICE CARD

Shortwave Receivers, Antennas
ICOM - KENWOOD - YAESU Etc.
Call 212-925-7000
Open 7 days a week, Mon.-Fri. 9am-6pm,
Thurs. until 8pm, Sat. & Sun. 10am-5pm

Barry Electronics
512 Broadway • New York, NY 10012
Sales & Service Commercial Radio For 35 Years

Please send all reader inquiries directly.

***** PRESENTING *****
CABLE TV
DESCRAMBLERS
***** STARRING *****
JERROLD, HAMLIN, OAK
AND OTHER FAMOUS MANUFACTURERS

- FINEST WARRANTY PROGRAM AVAILABLE
- LOWEST RETAIL/WHOLESALE PRICES IN U.S.
- ORDERS SHIPPED FROM STOCK WITHIN 24 HOURS

FOR CATALOG OR MERCHANDISE ORDERS ONLY **1-800-345-8927**
FOR ALL INFO REQUESTS - CALL (818) 716-5916

PACIFIC CABLE CO. INC.
7325 1/2 RESEDA BLVD., DEPT. 1118
RESEDA, CA 91335



Please send all reader inquiries directly.



PICKS UP A WHISPER 50 FEET AWAY!

The model WAT-50 miniature FM transmitter uses a 4-stage circuit NOT to be confused with a simple wireless microphone. Simply snap the unit on top of a 9V battery and you can hear every sound in an entire house up to 1 mile away! Use with any FM radio. Tunes to any frequency from 70mhz - 130mhz. Easy to assemble kit includes all parts and instructions. Only 29.98 tax incl.



The **WIRELESS TELEPHONE TRANSMITTER** model WTT-20 is only about the size of a dime, yet transmits both sides of a telephone conversation to any FM radio with crystal clarity. Completely automatic. Uses power from the telephone line itself - never needs a battery! Up to 1/4 mile range. Tunes from 70mhz - 130mhz. Easy to assemble kit includes all parts and instructions. Only 29.98 tax incl.

Call or send MO, VISA, MC for immediate delivery.
Single kit orders include \$1.50 S&H. FREE SHIPPING
on orders of 2 or more. All orders shipped by U.S. Mail.
COD add \$4.00. Personal checks allow 21 days.

DECO INDUSTRIES
BOX 607, BEDFORD HILLS, NY 10507
914-232-3878

CIRCLE 109 ON READER SERVICE CARD

LISTENING POST

BY GERRY L. DEXTER

WHAT'S HAPPENING: INTERNATIONAL SHORTWAVE BROADCASTING BANDS

For a number of years now the only opportunity to log Hong Kong on the shortwave broadcasting bands was by hearing the low power Radio TV Hong Kong during its every other year appearance as it provided weather and related information for the South China Sea yacht races. Now there's a new target. It's bigger and it's there for you to take your best shot on a year 'round basis.

The BBC's new Hong Kong relay station is supposed to begin its regular service within the BBC scheme on 27 September. The tentative schedule, announced on Radio Netherland's Media Network and sent in by J. D. Stephens, is 5965 and 7240 at 2200-2215 in Japanese, then the World Service at 1100-1145 on 5995 and 7180, 0345-0900 on 15280, 0845-0945 on 7180, 1245-1615 on 7160 and 2230-0430 on 15435.

The director of Radio Denmark has reportedly said that budget cuts might cause a suspension of the station's long-troubled external service. The current Radio Denmark 50-kW facility has served for several decades and is said to be inadequate for worldwide coverage. Lack of funds has prevented the establishment of the high power broadcast facility which had earlier been planned. The funding and upgrading of the Radio Denmark shortwave facility is not a high priority item with the Danish government, according to an item from Finn Stelmach which appeared in the *Australian DX News* publication.

You can find a little more English program time on the Radio France International airwaves these days. English news bulletins are now aired at 1110 on 9805, 11670, 11845, 15195, 15300, 15315, 15365 and 17620. English news bulletins are also carried at 0200, 0330 and 0415—which may be a simple rescheduling of the earlier 0315, 0330, 0415 and 0430 times. "Paris Calling Africa" continues to air at 1600.

Many of us recently carved another notch in our belts with the logging of the Marshall Islands' WSZO for a new radio country in our logs. Now it looks like the future has another Pacific island nation in store for our ears. Details are still sketchy but it seems that Radio Rhema, a religious broadcaster in New Zealand (1 kW on mediumwave 801 kHz) has received the go ahead to build a combination mediumwave, FM and shortwave outlet on Tonga. This is several months away, at the very earliest, and it's likely we'll be able to pass along more information before this one gets on the air.

Radio Discovery in the Dominican Republic is now scheduled to broadcast daily from 2100-0000 on 15045, then 0000-0300 on 6245. Manager Jeff White says

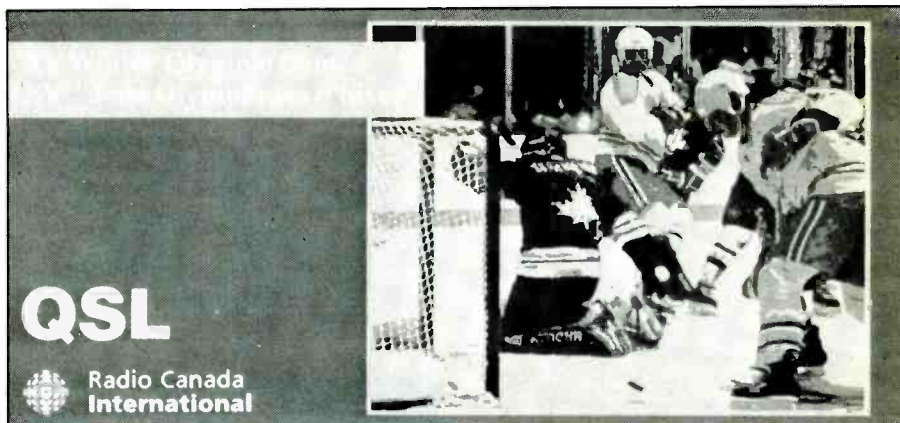

Radio Canada International's 1987-88 QSL commemorates the Winter Olympics.



Radio Tirana Albania's QSL shows the broadcasting building. Courtesy of Gerard Van Dobben, TN.

that a daily half-hour news feed in Spanish and English from United Nations Radio is carried at 2230 and a program service from the government station, Radio TV Dominicana airs at 2200. Operations may be somewhat spotty however, since there's a problem in getting consistent commercial power service.

Mark Huff of Loveland, Ohio recently toured the Voice of America's Bethany relay station at Mason, Ohio. Mark says the tours are available daily and are free. He notes the original transmitters were built from scratch and are still in service for some 20 hours a day. The site includes one 250, three 175, two 50, one 15 and one 5 kW transmitters plus 22 antennas on 730 acres. The 22 person staff includes many Hams.

Loy W. Lee, who is assistant manager and fine arts coordinator at KEKU-FM/WEKH Radio at Eastern Kentucky University in Richmond says he and five other DX'ers went on another DXpedition to the school's 1700 acre environmental "laboratory" at Maywoods in the southeast part of the state. So, when you see "DX Maywoods" in the loggings this time, it's the combined work of Loy and Dr. Joel Roit-



Here's what Mark Huff's shack looks like. He's from Loveland, OH.

man, Edward C. Shaw, Rod Miles, Jim McClure and Eric Petty. The group is planning another trip in the near future.

South Africa's Simon Illingworth confirms at least part of the IRC usage situation in that country. He says they are not available at post offices there and he doesn't believe they are redeemable either.

K.J. Hobbs, 88 Hillview in Hamilton, Ontario, Canada would like to correspond with other listeners who are using the Radio Shack DX-400 receiver.

John R. Leary, W9WHM, Fortville, Indiana says he first listened to shortwave on a crystal set back in 1929! He got his Ham license in 1953 and since then has worked all the countries it's possible to work—360 of them! He was one of the first "W's" allowed to work BY1PK in China after Beijing allowed the resumption of Ham operating. John says he's tried all the tube receivers over the years but still prefers his homebuilt model. And he notes that he's only a few miles from WHRI in Nobelsville and offers to send us some photos of the station. Thanks, John, they'd be very welcome!

That does it for now. Let's have your comments, questions, schedules, clippings,

VERIFICATION CARD

QSL.



Location U.S.A.
 Wavelength 7.985 kHz
 Date 26.12.86
 Time 15:30 (GMT)

Your reception report has been examined and found correct/~~incorrect~~.

Ray Pfaff
 Director (Broadcasting)
 Information and Broadcasting Department,
 Rangoon, Burma.

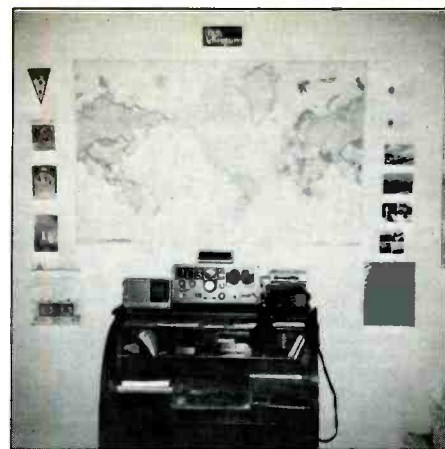

Dan Gotwact in Satellite Beach, Florida does his listening from this well-organized monitoring position.

This QSL from the Burma Broadcasting Service belongs to Ray Pfaff who heard the station from Florida but now lives much closer—in South Korea.

station information, shack photos, copies or spare originals of QSL's you don't need returned. Whatever. Loggings should be by country with (please!) your last name and state abbreviation after each, with some room to cut in between each logging and on only one side of the paper. It's a pleasure to hear from you and we hope you'll stay in regular, frequent touch.

(Linville, ALTA); 6060/7205/7215/9580 at 1510 1510 (Ritch, CA); 9655 at 0842 (Linville, ALTA); 9710 at 1211, into JJ at 1230 (Durant, NY); 9760 at 0753 s/on to Pacific; 0620 on 11945; 0301 on 15320/17715/17750/17795 (Moran, IL); 15160 at 0230 in FF (Northrup, MI); 15320/15395/17795 at 0152 (Ritch, CA).
 ABC Brisbane, 9660 at 1306 (Durant, NY).
 ABC Perth, 9610 at 1355 w/mx & nx (Northrup, MI); 15245 at 0704 w/cricket (Johnson, AZ).
 VNG time station, 12000 at 0625 w/ID (Van Waarde, CT).
 Austria: R. Austria International, 6155 w/"Report from Austria" at 0432 (Gilbert, CA).
 Belgium: BRT at 1337 on 15590 w/sports & ID (Neff, OH).
 Belize: R. Belize, 3285 in SS at 0114 (DX Maywoods).
 Brazil: R. Universario, Curitiba, 9545 at 0820 in PP w/pop mx (Moran, IL).
 R. Gaucha, Porto Alegre, 11915 at 2232 w/soccer game (Lingenfield, PA).
 R. Eandeirantos, Sao Paulo, 11925 at 0141 w/nx, ID's (Durant, NY).
 R. Inconfidencia, Belo Horizonte at 2315 on 15190 (Lingenfield, PA); 0055 w/mx, jingles, ID (Durant, NY).
 R. Globo, Rio de Janeiro, 11805 at 0138 w/ID's, pop mx (Durant, NY).
 R. Aparecida, Aparecida at 0210 on 11855, ID's time checks (Durant, NY).
 R. Nacional, Boa Vista, 4875 at 0208 w/mx, ID's (Durant, NY).
 R. Nacional Amazonia, 15200 at 1927 in PP (Lingenfield, PA).
 Radiobros, 11745 at 0240 (Smith, WI); 0245 mx & s/off (Northrup, MI).
 Bulgaria: R. Sofia, 6070 at 0000 in EE (Hobbs, ONT); 0400 on 7115 (Johnson, AZ); 0426 listeners' letters (Beard, AL).
 Burkina Faso: R. Burkina Faso at 0603 in FF on 4815, mx & ID (Van Waarde, CT); 11660 in FF at 1935 (Lingenfield, PA).
 Canada: CFRX Toronto, 6070 w/pops, commercial & ID at 1822 (Van Waarde, CT); at 1505 (Neff, OH).
 CHNX Halifax, 6130 w/CHNS relay at 1747 (Lingenfield, PA).
 CBC Northern Quebec Service, 9625 at 1600 (Hobbs, ONT); 6195 at 0307 in EE then into un-ID dialect (Johnson, AZ).
 RCI, 5960 at 0110 (Neff, OH); 9535 at 0116 (Gilbert, CA); 9650 in FF at 1255 & 11925 at 1240 (Northrup, MI); 5960/9755 at 0235 (Ritch, CA); 11945 at 2141 (Beard, AL).
 Chad: Rdfs. National Tchadienne, 0455 on 4920 s/on, anthem, mx & talks in FF (Gilbert, CA). Don't count on always finding them on 4920 kHz. Have been noted around 4900 kHz to avoid Libyan jammers-- Ed.
 China: R. Beijing, 6890 at 1210 in CC, 7480 at 1139 in JJ (Moran, IL); 9580 at 1323 & 9730 at 1308 (Bentler, WA); 11980 at 0445 (Johnson, AZ); 15120 at 0245 in SS (Van Waarde, CT).
 Central People's Broadcasting Station, 9800 at 1030 in CC (Stephens, AL); tentative on 7516 at 1131 in CC (Moran, IL).
 Colombia: R. Stutatenza, 5095 in SS w/talk (Northrup, MI). Time?-- Ed.

Cook Islands: R. Cook Islands, 11760 at 0418 in EE & Maori (Johnson, AZ); 0641 w/islands mx, dance hits, islands versions of US pops (Moran, IL).
 Costa Rica: R. Reloj, 6005.5 at 0638 w/mx & ID's in SS (Johnson, AZ).
 Cuba: R. Havana Cuba, 6090 at 0230; in SS on 11760 at 1330 (Northrup, MI); 6140 at 0400 (Hobbs, ONT).
 Czechoslovakia: QLB5 time station on 3170 at 0340 w/pips (Van Waarde, CT).
 R. Prague, 5930 at 0130 (Neff, OH); 0100-0200 & 0300-0400 on 5930/7345 (Hansen, IA); 0414 in SS (Gilbert, CA); 7345 at 0338 (Beard, AL); 9630 at 2330 (Hobbs, ONT).
 Dominican Republic: R. Discovery, 15045 at 2104 in SS w/mx & ID's (Durant, NY).
 R. Clarin, 11700 at 1510 w/ID's for Clarin & La Voz del CID (Neff, OH).
 East Germany: R. Berlin Int'l., 6010 to NA at 0446 (Lingenfield, PA); 0433 on 9560, also 15240 at 1557-1600 s/off (Johnson, AZ).
 Ecuador: R. Rio Amazonas, Macuma, 4870 at 0320 in SS, s/off at 0400 (Durant, NY).
 R. Zaracay, 3995 Santo Domingo de los Colorados, ID at 0140 w/accordion & orch in background (DX Maywoods).
 HD2IOA time sta in Guayaquil, 7600 at 0400 w/time sigs & ID in SS (Van Waarde, CT).
 HCJB on 6230 at 0630 (Gilbert, CA); 0100 at 9870 (Hobbs, ONT); 11835 at 0628 in GG (Moran, IL); 17790 at 1920 (Neff, OH).
 Egypt: R. Cairo, 0230 on 9475 (Johnson, AZ); 0219 on 9675 (Durant, NY).
 England: BBC (various sites) at 0202 on 5975//6005/9515; at 1600 on 6195//9740//11750//15260 (Ritch, CA); 9510 at 1230; 11750 at 1400; 15070 at 1855 and 15260 at 2025 (Northrup, MI); 9515 at 0100 (Hobbs, ONT); 1615 (Pellicciari, CT); 1734 on 9750 in language (Lingenfield, PA).
 Ethiopia: V. of Revolutionary Ethiopia at 1500 s/on w/guitar IS, then nx. Signals deteriorated after about 5 mins (Stephens, AL).
 Finland: R. Finland Int'l., 11715 at 0457 to mideast & Europe. Into nordic language at 0500; at 0443 & 1500 (Johnson, AZ); 11755 at 0530 w/IS & ID's in several languages including EE then into presumed Finnish (Gilbert, CA); 15400 in Finnish at 1430 (Hobbs, ONT).
 France: R. France Int'l. w/"Paris Calling Africa" at 1600 on 17620 (Pellicciari, CT, & Johnson, AZ); 7150 at 0325, 11670 at 1310 in FF (Northrup, MI); 0603 on 9790//11800 (Johnson, AZ).
 Medias France Intercontinents (pgm feed relay to African stars-- Ed.) via RFI on 17785 at 1515. Address? (Stephens, AL). Probably via RFI address-- Ed.
 French Guyana: RFI 5950 at 0157 in FF; also 0216 on 9800 (Ritch, CA); 0323 on 9790 (Beard, AL); 11670 at 1115 (Johnson, AZ).
 RFO Cayenne, 5055 at 0900 s/on w/nx & "Magazin" pgm (Stephens, AL).
 Gabon: Africa #1, 4830 at 0517 w/mx & talks in FF (Gilbert, CA); 15475 at 1903 in FF, into nx in EE, back to FF at 1907 (Johnson, AZ).
 Ghana: Ghana BC Corp., 3350 kHz at 0613 w/nx about Africa; on 3366 a rx pgm; ID "This

Abbreviations Used in Listening Post

- AA Arabic
- BC Broadcast/Ing
- CC Chinese
- EE English
- FF French
- GG German
- ID Identification
- IS Interval Signal
- JJ Japanese
- mx Music
- NA North America/n
- nx News
- OM Male
- pgm Program
- PP Portuguese
- RR Russian
- rx Religion/lous
- SA South America/n
- SS Spanish
- UTC Coordinated Universal Time (ex-GMT)
- v Frequency varies
- w/ With
- WX Weather
- YL Female
- // Parallel frequencies

SWBC Loggings

(All Times Are UTC; All Loggings EE Unless Otherwise Specified)

Alaska: KNLS at 0900-1100 on 5950 w/rx pgms & "American Music Spotlight" (Parker, ID).
 Albania: R. Tirana, 7065 at 0230 s/on (Gilbert, CA); 0332 w/nx on 7120 (Beard, AL).
 Girokastra home svc outlet, 5057 (varies) at 0511 in Albanian. QRM from Swaziland on 5055 (Lingenfield, PA).
 Algeria: R. Algiers, 9509 (varies) at 1905 to Europe (Lingenfield, PA).
 Antigua: Deutsche Welle relay station at 0317 on 6045 (Ritch, CA).
 Argentina: RAE in EE at 0154 on 9690 (DX Maywoods); 0441 w/DX pgm on 11710 (Gilbert, CA); 0054 in SS (Neff, OH).
 Armenia: SSR: R. Yerevan (via Moscow xmtrs) 11860 at 0348 w/"The Armenian Hour" (Johnson, AZ).
 Australia: R. Australia at 1600 on 5995//6060

is GBC, Accra" at 2300 (Lingenfield, PA); 4915 at 0612 w/nx (Gilbert, CA).

Greece: V. of Greece, 9395//9420 in FF at 0000 (Linville, ALTA); 0534 in Greek on 9420, also 2340 on 11645 (Johnson, AZ); 7430 in Greek at 0230 (Northrup, MI).

Guam: KTWR on 9840 w/address at 1550 (Ritch, CA).

Guatemala: TGNA R. Cultural, 3300 at 0302 w/rx pgm (Van Waarde, CT); 0125 in SS (DX Maywoods).

Honduras: HRRI Sani R., Puerto Lempira on 4755 at 0034 in SS w/mx, ID's (Durant, NY); at 0015 in SS & vernaculars (Lingenfield)

Hungary: R. Budapest, 6025 at 0111 (DX Maywoods); 9835 at 2100 w/nx (Pellicciari)

India: AIR, 11620 at 2015 to Europe, very weak (Lingenfield, PA).

Indonesia: V. of Indonesia, 11790//15150 in presumed Indonesian (Stephens, AL); 11790 at 1255 w/mx & ID (Northrup, MI).

Iran: VOIRI, 9022 at 1945 w/nx, "Enemies of Islam," "Analysis of the Arrogant Mass Media" (Pellicciari, CT); 0233 in Farsi (DX Maywoods); 0240 on 9022//15084, presumed Farsi (Johnson, AZ).

Iraq: R. Baghdad, 9870 at 2100-2140 (Hansen, IA); 11740 in AA at 2254, tentative (Lingenfield, PA).

Israel: Kol Israel, 7465 at 0158 in SS (Smith, WI); 0000 (Hobbs, ONT); 9435 at 0029 s/off & IS (Gilbert, CA); at 2130 (Watts, KY); at 0402; at 1425 on 15485 w/IS & into un-ID language; 1629 on 11710 w/IS & into un-ID language at 1630 (Johnson, AZ); 2132 on 9815 (Neff, OH).

Italy: RAI on 9575 at 0100 w/nx, into FF 0120, also on 11800 same hour (Johnson, AZ).

Japan: R. Japan, 5960 (via Canada) at 0340 w/DX show (Linville, ALTA); 5990 at 1509 (Ritch, CA); 7240 at 0924 (Bentler, WA); 11800 at 2303 w/nx (Beard, AL); 17810 at 0125 (Johnson)

Nihon SW BC Co. (NSB) "Radio Tanpa" at 0901 on 3925 w/"Hello People" pgm in EE & JJ (Gilbert, CA); 9595 at 0700 in JJ (Johnson, AZ); 0814 in JJ (Moran, IL); 0955 on 6055//9595 (Stephens, AL).

Kiribati: R. Kiribati, 14802 from 0017 to fade at 0036, DJ sounded like an Australian, w/pop mx (Pfaff, S. Korea).

Kuwait: R. Kuwait, 9840 at 0238 in AA, 'neath VOA (Johnson, AZ); 11675 at 2000 w/rx talk (Northrup, MI).

Libya: R. Jamahiriya, 7245 at 2000 w/commentary,

& ID's (Durant, NY).

Lithuanian SSR: R. Vilnius (via Moscow xmtrs) on 7165 at 2308 (Beard, AL); 13645 at 2300 (Johnson, AZ).

Marshall Islands: WSZO Majoro, 4940 at 0745 w/island mx, talks in Marshallese; nx in EE at 0800 (Stephens, AL).

Morocco: RTV Maracaine, 15105 w/mx at 0054 (Bentler, WA); 15330//15335 at 2040 w/talks in AA & mx (Durant, NY).

R. Medi 1 on 9575 at 1930 in AA. Xmtr in Nador (Lingenfield, PA).

Netherlands: R. Netherlands at 0810 to Australia on 9630 (Moran, IL); 13770 at 1500 w/Asian svc (Pellicciari, CT).

Netherlands Antilles: R. Netherlands relay on 6020 at 0330 (Hobbs, ONT); 6165 at 0232 (Ritch, CA).

Trans World R., Bonaire, 11815 at 1250 (Northrup)

New Zealand: R. New Zealand, 11780 at 0639 w/medical pgm (Moran, IL); 15150 at 0311 (Ritch, CA); 17705 w/bellbird IS at 0000 (Johnson, AZ).

Nigeria: FRCN Lagos, 4990 at 2205 s/off & anthem (Lingenfield, PA).

N. Korea: R. Pyongyang, 6576 at 2110 in FF to Europe (Lingenfield, PA); 11655 at 1230 in Korean w/o ID (Northrup, MI); 15140 at 0014 (Durant, NY).

Norway: R. Norway Int'l., 17840 at 1514 in Norwegian w/EE ID at 1518 (Johnson, AZ).

Peru: R. San Martin, Tarapoto, 4810 at 0605 w/mx, ID's simply as "San Martin" (Stephens)

R. Qollasuyo, Juliaca, at 0145. ID, chorus/guitars in SS (DX Maywoods). This one almost never reported in NA-- Ed.

Philippines: FEBC on 11850 w/nx at 1531 (Ritch, CA).

R. Veritas Asia, 9540 at 1458 w/EE ID & anct of Mandarin pgm to follow at 1500 (Gilbert).

Poland: R. Polonia, 9525 at 0346 to s/off at 0355 (Gilbert, CA); 9540 w/nx, DX Club (Pellicciari, CT).

Portugal: IBRA Radio (via R. Trans Europe, Sines) at 1920 in Romanian on 9685 (Lingenfield).

Romania: R. Bucharest, 5990 at 0201 w/nx & commentary (Beard, AL); 0406 on 9570 (Gilbert).

Rwanda: Deutsche Welle relay station 11750//11795 in GG (11750 from Germany) (Lingenfield, PA); tentative on 17765 at 1645 in possible Swahili, mention of Kigali (Johnson, AZ).

Saudi Arabia: BC Svc. of the Kingdom of Saudi Arabia, 15505 at 1450 on AA (Johnson, AZ). Not Kuwait??-- Ed.

Singapore: Singapore BC Corp., 11940 at 0622 (Moran, IL); Radio 1 svc at 1530, pop mx (Johnson, AZ).

Solomon Islands: SIBC at 9545 w/commercials, public svc ancts in EE & Pidgin (Johnson)

S. Africa, Rep. of: Radio RSA, 6010 at 0200 (Neff, OH); 6020 at 0230 (Hobbs, ONT); 6010//6185//9615//9685 at 0200 w/9685 a new freq & requested reports for that channel (Ritch, CA); 9585 at 0630 (Johnson, AZ); 11900 to 0626 close (Moran, IL).

Radio 5, 7170 at 0531 w/nx, flight arrivals (Johnson, AZ).

S. Korea: R. Korea, 15575 at 0042 in EE (DX Maywoods); 0200+ (Beard, AL; Ritch, CA; Van Waarde, CT).

Spain: Spanish Foreign R., 0513 on 6125 (Beard, AL); 9360 at 0236 in SS (DX Maywoods); 9630 at 0024 (Neff, OH); 11730 at 0458 w/anthem, into SS; 11880 s/on at 1930 (Johnson, AZ).

Surinam: R. Surinam Int'l. (via Radiobras, Brazil) 17755 w/"Know Your Roots" at 1740, s/off in Dutch at 1745 (Watts, KY).

Sweden: R. Sweden Int'l., 9695 at 2305 w/nx (Van Waarde, CT); 2259 s/on 9695//11705 w/ID & IS; 2300 w/"Swedish Spectrum": Swedish on 15345 to 1730 to close (Johnson, CT); 15345 in Swedish at 1430 (Hobbs, ONT); EE at 1400 (Pellicciari, CT).

Switzerland: Swiss R. Int'l., 6135 at 0220 plus 9885 at 1255 in CC (Northrup, MI); 9725 at 0220 (Beard, AL); 9885 at 0745 in GG (Linville, ALTA); 9885 at 0528 in FF; 12035 at 2040 (Johnson, AZ); 11955 at 2110 (Neff, OH); 1530 to Africa on 17830 (Pellicciari, CT).

Syria: R. Damascus, 9950 at 2117 (Lingenfield, PA); 0434 in AA 9950//12085; 12085 also 2005-2205 w/EE segment (Johnson, AZ).

Tahiti: R. Tahiti, 6135 at 0644 in FF & Tahitian (Johnson, AZ); 11825 at 0630 w/island mx (Moran, IL); 15170 at 0215 in FF, American rock mx (DX Maywoods).

Thailand: R. Thailand (tentative) at 0706 on 9675 w/nx of Southeast Asia, commentary on Thailand (Linville, ALTA). Doubtful. Listed & recently reported on 9665-- Ed.

Turkey: Turkey Police R., 6340 w/Turkish mx at 0830 (Potapov, USSR).

V. of Turkey, 9560 at 2301 w/nx (Beard, AL); At 0310 (Johnson, AZ).

Ukrainian SSR: R. Kiev (via Moscow), 13645 at 0315 (Johnson, AZ).

Unidentified: 9660 in SS at 0336. Rumbos? (Linville, ALTA). Probably-- Ed.

Afro-pop mx & FF ancts on 15345 at 2209 (Johnson, AZ).

AA at 0440 on 11675. Kuwait? (Johnson, AZ). Likely-- Ed.

AA at 0358 on 9515; 7475 in AA at 0625; 11865 at 0230 s/on in AA (Johnson, AZ). The 7475 is Tunisia-- Ed.

United Arab Emirates: V. of the UAE, Abu Dhabi, 9900 in AA at 0020 w/tone, into pprograms at 0030 w/chimes, Karan (Johnson, AZ).

UAE R. Dubai, 11940 at 0330, mailbag pgm (Johnson, AZ); 15320 at 1630 (Pellicciari, CT).

United States: WCSN Christian Science Monitor, Scotts Corner, ME on 7365 at 2240 (Van Waarde, CT); 2306 (Neff, OH); 9465 close at 2155, moved to 7365 (Watts, KY); 2030 on 9465 (Lingenfield, PA); 15270 at 1600 (Stephens, AL); 1605 on 15270 (Ritch, CA).

WHRI, 7355 w/R. Earth pgm at 0330 (Neff, OH); 0300 s/on on 7355; 1325 on 11790 (Northrup, MI); 7400 w/R. Earth at 0312 (Ritch, CA).

WYFR, 11830 w/rx pgm at 1325 (Northrup, MI); 1602 on 15170 (Ritch, CA).

WRNO, 6185 w/ID at 0400 (Neff, OH); 7355 at 0225 (Northrup, MI); 15420 at 1600 (Pellicciari).

WMLK at 1900 to Europe on 9455 (Lingenfield).

KVOH, 17775 at 2100 w/UPI nx (Lingenfield).

VOA, 5995 at 0500; 6130 at 0255; 11965 in CC at 1240; 0200 on 15205 (Northrup, MI); 0145 on 9455; 15410//15600 at 1618 (Ritch, CA); 15600 at 1815 to 1830 s/off (Durant, NY).

KCBI, 11735 at 2030 w/ID & QSL anct, rx pgm (Smith, WI); 1945 (Neff, OH); 1732 (Van Waarde, CT).

KGEI, 7365 at 0300 w/EE ID & into language (Beard, AL).

AFRTS, 6030 at 0155; 15260 at 0240 (Ritch, CA); 9700 at 1340; 15345 at 0205 (Northrup, MI).

USSR: R. Moscow, 5940//9810 in RR at 0840 (Linville, ALTA); 1530 in EE on 5950//6020//6155//7345//9510; 0214 on 7320//12050 (Ritch, CA); 0200 on 7450 (Smith, WI); 9775 at 1900; 11750 at 1320; 11790 at 0300; 11845 at 1245; 13625 at 1325 (Northrup, MI); 11845 at 0407; 15475 at 1535 (Johnson, AZ); 11950 at 1430 (Pellicciari, CT); 15475 at 1420 (Neff, OH); 17655 (possibly via Kabul relay) at 1435 (Durant)

R. Station Tikhii Okean, Vladivostok, 0740 on 9810, into RR at 0747 (Johnson, AZ); 7175//7260 in RR at 0730 (Bentler, WA).

Radiostansiya Atlantika, 11850 at 1300 w/nx & commentary (Stephens, AL).

R. Station Peace & Progress, to Africa at 0255 on 17850 (Moran, IL).

Vatican: Vatican R., 9605 at 0050, off 0110; 9755 at 0444 w/IS, into un-ID language; 0518 on 11715//11740 in EE (Johnson, AZ); 9645 at 0515 in EE, into II at 0520 (Gilbert, CA); 15120 at 1530 (Neff, OH).

Vietnam: V. of Vietnam, 9840 at 2033 w/nx commentary, off at 2057 (Durant, NY); 10010 at 1509 in presumed CC (Gilbert, CA).

Venezuela: R. Rumbos, 9660 at 2356 w/mx & talk in SS, many ID's, doorbell sound effects (Gilbert, CA).

W. Germany: Deutsche Welle (various sites) at 0458 on 5960, EE s/on; 17860 at 1915 in GG (Johnson, AZ); 6045 at 0330 (Beard, AL); 6145 at 0300 in GG (Northrup, MI).

Yemen, PDR: R. Sana'a, 9779 (variable) in AA at 1925 (Lingenfield, PA).

That's it. Our thanks to the following reporters this month: Alan R. Linville, Edmonton, ALTA; Warren Gilbert, Sherman Oaks, CA; K.J. Hobbs, Hamilton, ONT; Ted Moran, Chicago, IL; James W. Parker, Mt. Home, ID; Darwin Hansen, Rowan, IA; J.D. Stephens, Huntsville, AL; James Beard, Albertville, AL; Paul Johnson, Phoenix, AZ; Steve Pellicciari, Stamford, CT; John M. Bentler, Renton, WA; Charley Ritch, Newport Beach, CA; Darrell Lingenfield III, St. Thomas, PA; Alexander Durant, Albany, NY; Mark Northrup, Ann Arbor, MI; Doug Smith, Madison, WI; Loy W. Lee and the DX Maywoods Team, KY; K.C. Watts, Louisville, KY; Roy Pfaff, South Korea; Aren van Waarde, New Haven, CT; Alexi Potapov, Voronezh, USSR and George Neff, Niles, OH.

Back again next month. 'Til then, good listening!



ATTACH LABEL HERE

PLEASE PRINT

NEW ADDRESS HERE

NAME _____

ADDRESS _____

CITY _____ STATE _____ ZIP _____

DATE _____

POPULAR COMMUNICATIONS

76 N. Broadway,

Hicksville, NY 11801

SUBSCRIBER SERVICE

CHANGE OF ADDRESS

Planning to move? Please let us know six weeks in advance so you won't miss a single issue of POPULAR COMMUNICATIONS

Attach old label and print new address in space provided. Also include your mailing label whenever you write concerning your subscription to insure prompt service on your inquiry

RADAR REFLECTIONS

RADAR DETECTORS AND THEIR USE

BY JANICE LEE

Lawmaker's Defeat Removes Roadblock To CHP Radar Use

A major change in the California legislature will be the absence of "Leadfoot" Lou Papan, considered to be the Number 1 opponent to the use of radar to catch speeders. In his 14 years in the Assembly, the Democrat led opposition to put radar in CHP patrol cars.

In 1986, Papan gave up his seat for a shot at the State Senate, a move that ended with his narrow loss to San Francisco Supervisor Quentin Kopp. However, Papan's departure doesn't necessarily mean the California Highway Patrol will get its long-sought authority to use radar.

Says Kent Milton, CHP spokesman: "Papan really didn't stand alone in opposition to radar, so we don't expect any change in the Legislature's posture. There's no plan afoot on a general basis to use radar."

While Papan didn't stand alone, he did form the most formidable and feared roadblock.

It was Papan, known as "The Enforcer" in his role as chairman of the Assembly and Joint Legislative rules committees, who revoked parking places in the Capitol garage for Governor Deukemejian's aides during the 1983 state budget battle.

It was Papan, landlord of office space for the Assembly, who moved members to smaller quarters for not toeing the leadership line.

His traffic record included at least two speeding tickets, reinforcing his nickname "Leadfoot" and one publicized instance of trying to pull rank on a patrolman.

CHP Commissioner James Smith said that even with its most vocal critic gone, enough radar foes remain to block and authorization bill. In the past, through budgetary votes, the legislature has prevented the CHP from gaining radar equipment and once required the patrol to turn down a federal grant for the purpose.

However, the use of radar in California is spreading. The CHP received authority two years ago to use radar on State Route 126 in Ventura County, where there had been a number of traffic deaths. Radar will also be used in 1987 on State Route 74, the Ortega Highway, which runs inland from San Juan Capistrano.

Also, 21 counties, including San Diego, have asked the CHP to use radar on county roads, with the counties providing the equipment. This began in Contra Costa County in 1981.

Assemblyman Richard Katz (D-Sepulveda), chairman of the Assembly Transportation Committee, said Papan was the "focal point of opposition" to radar and that other legislators didn't support its use for fear of

angering Papan. However, he said, "Most people are happy with the county-by-county option," which might someday lead to support for a statewide program.

Would-be Thieves Foiled

Two 20-year-old men apparently picked out the wrong vehicle from which to steal a radar detector recently—an unmarked Troy, Michigan police car!

According to Sterling Heights police, a Troy police officer drove and parked his unmarked patrol car in the lot of a bowling alley on 16 Mile Road west of Dequindre recently and followed some people into the facility.

Police said a car with the two suspects pulled up next to the police car. One of the men opened the door of the police car and allegedly took a radar detector.

The pair was observed by two other Troy policemen parked in the lot. Troy police followed the pair out of the lot, pulled them over and called in Sterling Heights police to make the arrest.

New Jersey Will Set Standards For Police Who Use Radar

The state of New Jersey will implement standards for the use of radar equipment used by police, as a way to make speeding charges stand up in court, Attorney General W. Cary Edwards said recently.

"This will ensure that anyone who uses a radar gun will be properly trained and certified," said North Plainfield Patrolman Ed McBride, traffic safety chairman of the New Jersey Police Traffic Officers Association.

The standards are included in a voluntary certification program set up by the Division of Criminal Justice and the Police Training Commission.

The commission establishes police officer training programs and is made up of law enforcement officials, representatives of federal agencies and educators.

The commission has been certifying radar instructors to train officers in the use of the radar equipment, but there have been no statewide standards for radar gun operators.

Alabama Supreme Court Says Radar Detectors Are Legal

The court's decision came in a Crenshaw County case involving District Judge William R. King, who had a standing rule that any speeder using a radar detector had to pay a fine \$50 higher than other speeders.

James E. Ellis was convicted of speeding in King's Court in August, 1985, and the judge fined him \$117—including \$67 in normal fines and the \$50 radar fine.

Testimony from an Alabama State Trooper revealed that a disconnected radar

detector was found on the floorboard of Ellis' car. The trooper wrote "radar detector in use" on the citation.

Prosecutors justified King's policy by contending that drivers using radar detectors are intentionally attempting to violate state traffic laws. The higher fine discourages use of the devices to flout Alabama law, state attorneys argued.

The Alabama Supreme Court, however, ruled that King's policy was wrong and overturned Ellis' speeding conviction. The court, in effect, further ordered King to end the extra fines.

I commend James Ellis for his bull-dog determination and for restoring constitutional rights to the motorists traveling through Crenshaw County.

19 Police Radar Jammers Seized From Truck Stop

Undercover Iowa State Patrol troopers have seized 19 police radar jammers valued at about \$9,500 from the Crossroads USA truck stop in Urbandale, a patrol official said recently.

Noble alleged that the truck stop was selling them for about \$500 each. The devices, illegal in Iowa, make it impossible for radar to measure a vehicle's speed.

Troopers seized the devices after arriving at the truck stop about 2 a.m. in an unmarked car and asking a clerk about them. "This was quite a seizure," since troopers usually take jammers from motorists one at a time, Noble said.

The troopers tested the devices, which are about half the size of a shoe box, and are described by the manufacturer as "Amateur radio FM transmitters." Noble said troopers plan to ask the Polk County attorney's office to file misdemeanor charges.

James Spacek, general manager of the truck stop at Interstate Highway 35 and Douglas Avenue, said the units are used to test radar detectors and that Crossroads officials were told by distributors that the devices are legal. "If it was an illegal thing, we wouldn't sell it," he said, adding that the seized devices were from the first shipment the truck stop received.

Iowa law prohibits sale, use or possession of radar jammers and allows police to confiscate them. Noble said the jammers are a much more serious law enforcement problem than radar detectors. The most sophisticated jammers can make a radar read 55 mph while the motorist drives much faster, Noble said.

Some of the devices will be used to train troopers. The other units will probably be destroyed, he said.

PC

Janice Lee is the Editor of Monday, A.M., the newsletter of Electrolert, Inc.

CLANDESTINE COMMUNIQUE

WHAT'S NEW WITH THE CLANDESTINES

BY GERRY L. DEXTER

In the June 1987 column, we had mentioned that Radio Ba Yi (First August Radio, named after the date in 1927 on which the People's Liberation Army was founded) had once again disappeared from the airwaves—probably due to a reduction of tension between Moscow and Beijing. Listeners who could understand Chinese often got an earful from this clandestine station.

For example, according to a *Miami Herald* story earlier this year, the station claimed that unemployed workers in Beijing were committing suicide and that several armed insurrections had broken out in various provinces in recent years. During the 1983 visit of U.S. Secretary of Defense, Caspar Weinberger, the station reported that Weinberger had said that Chinese soldiers couldn't shoot straight because they were cross-eyed, and bragged about raping Chinese girls in World War II. The station also claimed that leader Deng Xiaoping surrounds himself with attractive young nurses and pays no attention to his wife. Just the kinds of things you'd expect to hear on a clandestine station, no?

Hopefully, relations between these two countries will continue to improve, but if they don't, we might well expect the return of First August Radio.

The Voice of Palestine, which is the radio program produced by the Palestine Liberation Organization and aired over some stations in the Middle East and Africa, has been verified. The Voice of Palestine via Radio Algiers, daily at about 1705 UTC on 15215, has been confirmed by letter from Said M. Hamad, Assistant Director, Palestine Information Office, 818 18th Street, Suite 620, Washington, D.C. 20006.

The anti-Sudanese station Radio SPLA is currently being heard fairly well in various parts of the U.S. with its English language segment which is aired at 1300 on SPLA's recently instituted frequency of 11710. This station is an operation of the Sudan People's Liberation Movement/Army but, unfortunately, we are making no progress in locating an address for the SPLA office.

Vietnamese Resistance Radio, which operated on 7355 and was later said to be using 7320, still seems to be inactive. At least that's the word from one of our contacts who spent some time in Vietnam recently. The station was unheard, despite extensive checks. The broadcaster was (or is) believed to be located in the "Parrot's Beak" area, just across the Vietnamese border in Cambodia. Our correspondent says that the "street talk" in Saigon is that the station might return to the air if given some funding by the Vietnamese liberation groups active in the U.S. and other countries.

The National Front for the Salvation of Libya

NEWS LETTER

Attn: QSL, 3215 Franklin Ave. A 216 Chicago, Illinois 60646, 7003 U.S.A.

No 56 April 1987

SUDAN - THE NEXT TARGET DEFEATED AND DEMORALISED . . . INCREASING ISOLATION . . . WHOSE POW'S? PLAYING THE GAME GADDAFI'S CHAD FACTOR TOOTHLESS AMBITIONS PURE HOLLYWOOD

SUDAN - THE NEXT TARGET

As usual, Gaddafi is trying very hard to dismiss, publicly, the effects of the colossal defeat he suffered in Chad. He is offering to mediate for peace in the Aegean between Turkey and Greece, for unity within the PLO and is totally preoccupied, although a little belatedly, with Libya's chronic economic problems. But no one is fooled. With over 3000 Libyans killed and 1,500 captured by the Chad government forces, including a number of high ranking officers (Co. Khalifa Hifter, Col. Abdelkadir Sherief, Col. Salem Bunawara, to mention but a few) as well as at least 50 women soldiers, Gaddafi is frantically looking for excuses, diversions and scapegoats.

Sudan has also grown increasingly irritated with Libyan military activity on its western border with Chad. Early in March a Libyan military column entered Sudanese territory in an attempt to mount an attack south of the sixteenth parallel. When its presence was discovered it was immediately described by Tripoli as a "relief column" bringing aid, presumably, to Chadian refugees inside Sudan. This bogus statement further angered the Sudanese government who demanded its immediate withdrawal. The Libyans are taking their time to leave the Sudan - taking advantage, too, of the confused situation in the area. To date they still have not left Sudanese territory.

We again emphasise here that Sudan is Gaddafi's new target. After several denials, the Sudanese government has now admitted Gaddafi's military presence in northwest Sudan, threatening Sudan's own sovereignty and stability.

NFSL sources confirm that Gaddafi's forces are well entrenched in Sudan where he intends to reinforce for attacks against Chad. Gaddafi's need to keep the Libyan army preoccupied outside Libya and the mobilisation efforts being carried out inside the country indicate that his intentions in

Sudan are not temporary. Orders have gone out to all army officers released since September 1969 to join their units. Libyan missions abroad have been instructed to account for all military students and trainees in preparation for their return home and all Chadians remaining in Libya are being picked up and drafted into military camps in the South. Furthermore, huge quantities of poison gas, napalm and other chemical weapons, some of which are made in a factory at Tamahnint, 30km north of Sebha, are being amassed in the southern regions.

In a closed meeting with senior army officers at al Jufra on 29 March 1987, Gaddafi blamed his officers for the Chad defeat and threatened severe punishment. He also stressed the need for an "all-out final attack" on Chad from the North and the East simultaneously. Sadiq al-Mahdi's threat to relinquish power if he could not deal with the Chad problem shows that he is fearing the worst.

DEFEATED AND DEMORALISED

As his beaten army heads northwards from Faya Largeau to the apparent safety of the Libyan border, Muammar Gaddafi must be reflecting on the gravity of his position. This is his retreat from Moscow, as serious for him as it was for both Napoleon and Hitler whose own grandiose ambitions were thwarted by the harshness of the Russian winter and the courage of the Russian people. The scale may be different but the portents are just as ominous for this modern dictator.

The war, a totally unjustified military adventure which has brought only hardship and suffering to the people of Chad (one of the poorest countries in the world) - has been hugely unpopular in Libya. The annexation of the Aouzou strip, the Libyan invasion in 1983, the arbitrary Libyan presence in the north of the country - while the French held the balance up to the sixteenth

Newsletter of the National Front for the Salvation of Libya which has a Chicago mailing address while QSL's come from the Washington, D.C. area. This newsletter was mailed from the United Kingdom. The Front operates the Voice of the Libyan People.

The anti-Castro station La Voz de Alpha 66 continues to be moderately active on variable 6666 MHz. It's scheduled for about 30 minute broadcasts on Monday, Wednesday and Friday at 0100 but has recently been heard at 0200 instead.

Simon Illingworth in South Africa provides us with some notes on stations operating in that part of the world. The SWAPO "Voice of Namibia" program is on Mondays, Wednesdays and Fridays at 1900 over ZBC Radio 1, Zimbabwe on 3396. Not

much chance that broadcast could ever be heard here.

Simon says that Radio Freedom, the African National Congress program, is carried on Radio Madagascar on 6135 from 1600 to 1800, but that's another one we aren't likely to hear. The address for that particular program is P.O. Box 80, Antananarivo, Madagascar.

Simon also hears Radio Truth operating on 90 meters near Zimbabwe's 3396. This must be a second transmission time as we

continue to hear Radio Truth from 0430 sign-on, on 5015. Thanks for the information, Simon, and yes, we'd be most interested in a tape. Thanks.

Speaking of tapes, Vashek Korinek, also from South Africa and a first-rate clandestine monitor, has a cassette of "Rarely Heard Middle Eastern Clandestine Stations" for sale. All cuts on the tape are good quality and include ID's. Available for \$7 surface mail or \$10 airmail from Vashek Korinek, P.O. Box 910, Edenvale 1610, Republic of South Africa.

The contra mediumwave station, Radio Liberation, has been logged in the United Kingdom. Steve Whitt of Ipswich heard the station on its 1520 frequency while on a DXpedition in Wales. Steve, by the way, is an editor for the *Medium Wave Circle*, a British DX club.

The anti-Castro Radio Caiman is reported by Wisconsin's Doug Smith on 7470 at 0155 with commentary, ID, and 30 minutes of rock music. Doug notes that someone at the station seems to have a weakness for The Beatles.

La Voz del CID was noted at 2355 on 9940 by Al Durant in New York who also found the anti-Sandinista La Voz de UNO of the (not so) United Nicaraguan Opposition on 5890 at 0230. Both stations only in Spanish, of course.

That's it for this time. Remember to forward your loggings of clandestine stations as well as any background information you run across or can dig up. It's appreciated! **PC**

"The Best Results throughout the Shortwave Spectrum."

—Larry Magne, *Radio Database International White Paper*

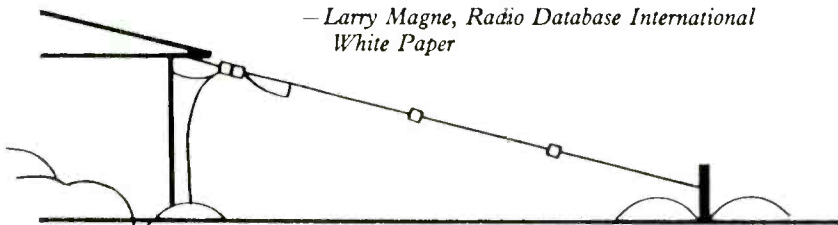

Get world-class, multi-band reception with
ALPHA DELTA DX-SWL SLOPER ANTENNA
Just \$69.95 plus shipping from your Alpha Delta dealer!

- Fully assembled, ready to use and built for long life. So strong, it can even be used to transmit—up to 2 kW!
- Superior multi-band performance on 13, 16, 19, 21, 25, 31, 41, 49, 60, 90, 120 meters plus the AM broadcast band (.5-1.6 MHz). All in a single compact antenna. Alpha Delta first!
- Efficient multi-band frequency selection by means of special RF choke-resonators—instead of lossy, narrow band traps.
- Overall length just 60 feet. Requires only a single elevated support—easier to install than a dipole
- 50 ohm feedpoint at apex of antenna for maximum DX reception. A UHF connector is provided on the mounting bracket for easy connection to your coax.
- A top overall rating in Radio Database International's hard-hitting White Paper, "RDI Evaluates the Popular Outdoor Antennas."

ALPHA DELTA

P.O. Box 571 • Centerville, Ohio 45459

There's alot happening on the shortwave broadcast bands. Don't miss a thing by skipping on your antenna. Get world class, multi-band DX reception with the Alpha Delta model DX-SWL Sloper. Just \$69.95 plus shipping from your local Alpha Delta dealer.

CIRCLE 107 ON READER SERVICE CARD

GRUNDIG® Satellit 400



The Grundig Satellit 400 represents German engineering at its best. This high-tech luxury portable provides exceptional features, excellent performance and an affordable price. Includes LW/MW/SW/FM, LCD digital readout, 24 memories, scan, keypad, bass/treble, clock, & SSB. **Available now for \$399.00 (+2.50 UPS)**



UNIVERSAL SHORTWAVE RADIO
1280 Aida Drive
Reynoldsburg, Ohio 43068
Phone 614-866-4267

New The All New 1988 RADIO DATABASE INTERNATIONAL *we've got it!*

The ultimate shortwave frequency guide is now available in an all new, completely revised and updated 1988 edition. And we've got it!

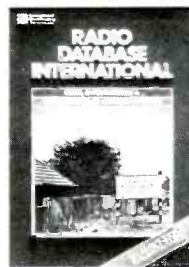

- Authoritative, complete 2 to 27 MHz shortwave coverage
- Easy-to-use computer generated graphics arranged by frequency
- Station names, locations, times, languages, power and more
- Larry Magne's annual Buyer's Guide to short-wave radios
- Dozens of articles to help you get the most from your radio
- The bible of shortwave broadcasting

BUY WITH CONFIDENCE. Use your Mastercard or Visa and call toll-free 1-800-323-1776, ext. 126—24 hours a day, 7 days a week. Or send your check or money order for \$14.95 plus \$2.16 for fast, fully insured UPS shipping. (PA res. add 6% sales tax) to Imprimé, P.O. Box 241, Radnor Station, Radnor, PA 19087.

THE SLOPER SWL ANTENNA. \$65.40! ON SALE.
We now carry the top-rated Alpha Delta Sloper shortwave antenna. Fully assembled and ready to use. Easy connection to your coax cable. Plus \$2.62 for fast, fully insured UPS delivery. Due to this low price, antennas are not returnable except in case of defect.

COMMUNICATIONS SHOP

Advertising Rates: SCAN members and POP/COMM subscribers are entitled to one-FREE 30-word, non-commercial classified ad per year. Enclose subscription name label with ad copy. For those people not in the previously mentioned groups, non-commercial ads are 30 cents per word, including abbreviations and addresses; minimum charge \$6.00 per issue. Ads from firms offering commercial products or services are \$1.00 per word; minimum charge \$20.00 per issue. Boldface words are \$1.20 each (specify which words). Leading key words set in all caps at no additional charge. All ads must be prepaid in full at time of insertion; a 5% discount is offered for prepaid 6 time insertions. All ads must be typewritten double spaced.

Approval: All ad copy is subject to Publisher's approval and may be modified to eliminate references to equipment and practices which are either illegal or otherwise not within the spirit or coverage scope of the magazine.

Closing Date: The 10th day in the third month preceding date of publication. Because the advertisers and equipment contained in Communications Shop have not been investigated, the Publisher of Popular Communications cannot vouch for the merchandise listed therein. Direct all correspondence and ad copy to: PC Communications Shop, 76 N. Broadway, Hicksville, NY 11801.

JUST STARTING IN SHORTWAVE? Get off on the right foot. Discover the wonders of shortwave along with cartoon character "O.H." in *So You Bought A Shortwave Radio!* A light 'n lively starter's book by Gerry L. Dexter. Just \$6.95 plus \$1 shipping (\$2 foreign) U.S. Funds from Tiare Publications, P.O. Box 493, Lake Geneva, WI 53147.

HAMS AND HAM BAND LISTENERS—get in on the net action with *The World Ham Net Directory* by Mike Witowski. Lists Ham nets around the world by name, frequency and meeting time. Only \$9.95 plus \$1 shipping (\$2 foreign) U.S. funds only, from Tiare Publications, P.O. Box 493, Lake Geneva, WI 53147.

RTTY MAKES SENSE after you've read *Radioteletype Monitoring—The Complete Guide* by Dallas W. Williams. Step by step, start to stop. Simply and clearly explained for both the beginner and the seasoned veteran. Includes over 350 best bet frequencies. Just \$9.95 plus \$1 shipping (\$2 foreign) U.S. funds please, from Tiare Publications, P.O. Box 493, Lake Geneva, WI 53147.

RADIOTELETYPE-SHORTWAVE-FACSIMILE Books, unusual, hard-to-find latest publications. Satellite communications, scrambling. Many titles. Free catalog. Universal Electronics, Inc., 4555 Groves Road, Suite 13A, Columbus, OH 43232. (614) 866-4605.

Broadcast Radio and Television Handbook (1983) I've recovered a number of my out-of-print technical handbooks of broadcasting. Books are in excellent condition. Length is 470 pages plus hundreds of illustrations. Covers AM-FM-TV broadcasting equipment from studio to antenna with a special emphasis on transmitters. Includes a top-detailed discussion of how a television signal is formed and transmitted. Other topics are transmitter test and monitoring equipment, antennas and lines, studio and control room equipment, stereo facilities, etc. Available at a bargain price of \$10 postpaid USA. Ed Noll, Box 75, Chalfont, PA 18914.

WANTED: Cash paid for used SPEED (TRAFFIC) RADAR EQUIPMENT. Write or call: Brian R. Esterman, P.O. Box 8141, Northfield, IL 60093, (312) 251-8901.

RECEIVERS FOR SALE: UHF military, satellite, tunable, programmable, scanners, antennas, test equipment. Call (419) 726-2249.

SIDEBAND OPERATORS! Join the oldest/largest network of 27 MHz SSB operators. Now more than 100,000 strong! Send self-addressed stamped long (#10) envelope for FREE details and application (no obligation). SSB Network, P.O. Box 908, Smithtown, NY 11787.

BIG! AIR-SCAN 4th Edition by Tom Kneitel. At last, a complete directory of aero communications stations/frequencies! Now in gigantic 120 page large-size (8½ x 11) format containing 40,000 listings (USA/Canada/Mexico/PR), including worldwide HF (2-30 MHz) freq. guide. In addition to 118-136 MHz VHF aero band scanner listings, also covers 30-50, 138-174, & 400+ MHz aero freqs. never before published. AIR-SCAN covers civilian/military airports, also "unlisted" airports not open to public, FAA freqs, FSS, towers, Unicom, airport security and operations freqs, new airfone air/ground telephone freqs, "hidden" business-band aero stations, military, traffic choppers, aero weather, federal agency aero, flight schools, aircraft mfrs., crop dusters, air ambulances and much more throughout USA. Largest directory of all-band aero radio communications ever published. Includes how-to text on aero monitoring and equipment selection. Only \$10.95 + \$1 shipping to USA/Canada/APO/FPO. Order from CRB Research, P.O. Box 56, Commack, NY 11725.

NORTH AMERICAN RADIO-TV STATION GUIDE by Vane Jones. 15th Edition! Thick 226-page book listing all US/Canadian/Mexican/West Indies AM/FM/TV broadcasters according to location/frequency/callsign, plus TV network affiliation, AM station day/night power, schedule data, etc. Painstakingly complete, accurate, up-to-date. The ultimate broadcast station directory. Only \$9.95 (plus \$1 postage) from CRB Research, P.O. Box 56, Commack, NY 11725.

CB RADIO OWNERS! We specialize in a wide variety of technical information, parts and services for CB radios. 10M-FM conversions, repairs, books, plans, kits, high-performance accessories. Our 11th year! Catalog \$2. CBCL, Box 31500PC, Phoenix, AZ 85046.

COLLINS AS-140S log periodic antenna. 225 to 400 MHz. New, in transit case. \$120. SASE and \$1.00 for list of comm. and test equipment. Michael P. Murphy, 11621 Valle Vista Rd., Lakeside, CA 92040, (619) 561-2726.

OLDTIME RADIO BROADCASTS. Classic programs from radio's golden age, on high-quality tapes. Mystery and adventure! Comedy! Drama! Music! Write for your free catalogue. Carl P. Froelich, 2 Heritage Farm, New Freedom, PA 17349.

PROPAGANDA TAPES! Authentic, rare recordings of WWII German and Japanese shortwave broadcasts by "Tokyo Rose," "Axis Sally," others. Cassette \$9.95. D-W Research, 4548 Auburn Blvd., #231-B, Sacramento, CA 95841.

CB RADIO OWNERS!

We specialize in a wide variety of technical information, parts and services for CB radios. 10M-FM conversions, repairs, books, plans, kits, high-performance accessories. Our 11th year! Catalog \$2.

CBC INTERNATIONAL, P.O. BOX 31500PC, PHOENIX, AZ 85046

SWL Receivers, Antennas, Books ICOM KENWOOD YAESU



Michigan Radio
Sun, Mon — Closed
Tue, Wed — 10-6
Thu, Fri — 10-9
Sat — 10-4

313-469-4656

We accept Visa,
Mastercard & COD's

28360 South River Rd. • Mt. Clemens, MI 48045

TUBES — 2000 TYPES DISCOUNT PRICES!

Early, hard-to-find, and modern tubes. Also transformers, capacitors and parts for tube equipment. Send \$2.00 for 20 page wholesale catalog.

Antique Electronic Supply

688 W. First St. • Tempe, AZ 85281
602/894-9503

CIRCLE 33 ON READER SERVICE CARD

Order Form

Please print in block letters.

POPULAR COMMUNICATIONS 76 North Broadway, Hicksville, NY 11801

Name _____
Street _____
City _____
State _____ Zip _____

1	2	3	4	5
6	7	8	9	10
11	12	13	14	15
16	17	18	19	20
21	22	23	24	25
26	27	28	29	30
31	32	33	34	35

PROTECT YOUR SCANNER! Quality leather case for RS PRO-30 \$45 (add \$4 p&h) others available on request, send check or M.O. ALEXANDER, P.O. Box 1556, Kitchener, Ontario, Canada N2G-4P2.

SELL VHF/UHF Ham and scanner antennas. Ed Noll, Box 75, Chalfont, PA 18914.

TELEVISION SETS made before 1946 wanted for substantial cash. Especially interested in "mirror-in-the-lid" and spinning disc sets. Finder's fee paid for leads. Arnold Chase, 9 Rushleigh Road, West Hartford, CT 06117. (203) 521-5280.

"MOST DANGEROUS BOOK EVER PUBLISHED"—NBC. CAN YOU—duplicate CIA tricks: open locks, safes, save on surveillance gear, listen thru walls, see in the dark: get unlisted phone numbers, credit/personal records, beat the lie detector, chemically read thru envelopes, etc? HOW TO GET ANYTHING ON ANYBODY, 264 pages, 8 1/2 x 11. \$33.00 postpaid. CEP, INCORPORATED, P.O. Box 865-MPA, Boulder, CO 80306, (303) 443-2294.

HARD AND FAST INSIDER INFORMATION: electronic weapons, latest surveillance, camouflage, poisons, tracking, tracing, starlight hiding, passports/ID's, shooting, trick ammo, counter-surveillance, offensive driving, telco tricks, security, lockpicking, codes, data banks, etc. BUILD YOUR OWN starlightscope, 007 briefcase, bulletproof vest, assault weapon system, silencers, surveillance gear, penguin, etc. FROM IR MONITORING TO ROCKET PISTOLS: FROM SUPER RIFLES TO MINDREADING... KEEP THE EDGE! NINJA 1990 by French/Lapin. 500+ pages, 8 1/2 x 11, hardbound, \$48.00 postpaid. CEP, INCORPORATED, P.O. Box 865-MPB, Boulder, CO 80306. (303) 443-2294.

ELECTRONIC SPYING is the name of the game. It's also the title of a startling book which reveals the closely guarded methods & equipment used by professionals & amateurs who eavesdrop on homes & businesses with (sometimes) legal and (usually) illegal bugs & wiretaps. Written in non-technical language everyone can easily understand, ELECTRONIC SPYING has photos & illustrations clearly revealing exactly how they do it & where they get the equipment (much of it inexpensive & easily available). Leaves nothing to the imagination! Latest techniques covered & offers an in-depth wealth of information on the ever increasing electronic invasion unavailable from any other source. This book is used by law enforcement agencies as a reference manual. Only \$8.95 (plus \$1.00 postage) per copy from CRB Research, P.O. Box 56, Commack, N.Y. 11725.

WORLD'S MOST UNUSUAL Communications Books! A large selection of outstanding titles covering scanners, "confidential" frequency registries, bugging, wiretap ping, electronic surveillance, covert communications, computers, espionage, monitoring, and more! New titles being added constantly! Ask for our large new FREE catalog. CRB Research, Box 56-PC, Commack, NY 11725.

COMMUNICATIONS PLANS, BOOKS, KITS! AM/FM broadcasting (licensed/unlicensed), 1750 Meter transceivers, Ham/CB amplifiers, surveillance bugs, more. FREE catalog. PAN-COM, Box 130-P9, Paradise, CA 95967.

HISTORIC WIRELESS/RADIO ARCHIVES! Tom Kneitel's new book, "Radio Station Treasury (1900-1946)." Gigantic 176-page compendium listing stations that operated between the dawn of the spark era & the end of WWII. A profusion of frequencies, skeds, call signs, slogans, licensee data, power, locations, etc. Covers the world's AM band & SW broadcasters, "utes," point/point, press, aviation, maritime, police, federal, military, experimental, longwave, early FM/TV, secret WWII propaganda stations, more! Comprehensive sourcebook directory packed with huge array of fascinating features & facts about tens of thousands of stations in every nation & category, of every size & type! Unique reference guide, nothing ever before like it! Research radio history in your own community & throughout the world. Personally autographed by the author (upon request when ordering). Only \$12.95 plus \$1 postage (USA/Canada/APO/FPO) from CRB Research, P.O. Box 56, Commack, NY 11725.

ESPIONAGE/EMBASSY Communications Guide, by Tom Kneitel. What's behind mystery "numbers" transmissions, coded embassy messages, and stations operated by foreign governments in the USA & Canada. How nations monitor each other's official codes and communications. Illustrated! Includes largest/latest registry of stations (frequencies/call signs/locations/modes) operated embassies of the world's governments, intelligence agencies, U.N., Interpol, International Red Cross, U.S. State Department, HF/VHF/UHF. Now you can tune in on Embassy & Espionage Communications is \$10.95 + \$1 postage (USA/Canada/APO/FPO) from CRB Research, Box 56, Commack NY 11725.

"BUY/SELL/TRADE" WANTED: Clean, used shortwave, scanners, CB, and late Ham gear. Our 31-page picture catalog is \$1.00, and one stamp for our Used Gear List. We sell Regency, Bearcat, Kenwood, Yaesu, Sony, ICOM, + MUCH, MUCH, MORE!! Galaxy Electronics, Box-1202, 67 Eber Ave., Akron, OH 44309. (216) 376-2402 9-5 pm EST.

FCC COMMERCIAL GENERAL Radiotelephone License Correspondence Course. 60 individual lessons for \$89.50. Payment plan. Results guaranteed! Detail free. AMERICAN TECHNICAL INSTITUTE, Box 201, Cedar Mountain, NC 28718.

WANTED: DRAKE DSR-1 or DSR-2 Communications Receiver, (nixie display) in complete unmodified condition ("not working" considered, too). Will pay extra for excellent or mint condition. Richard B. Powell, 228 Hibiscus Court, Newmarket, Ontario, CANADA L3Y 5K9, or call (416) 474-2494 (days), (416) 895-9781 (evenings).

\$\$\$ MASSACHUSETTS \$\$\$ A thru Z emergency services, needs extra eyes & ears to report: fire, break in, etc. Call (617) 884-0708 to learn how to earn finders fee.

BANDE; A TO Z—HOW TO GET IN ANYWHERE, ANYTIME. The Most Dangerous Video Ever Produced. Almost 2 hours of actual, on-site trick techniques to get in any building, beat any lock, open any safe, enter any car. The real experts teach the real stuff. \$99.95 and worth every red cent. Specify VHF or Beta. CEP, P.O. Box 865-MCP, Boulder, CO 80306.

LIGHTNING RODS Do it yourself. Free information parts catalog and installation instructions. Automatic Security, 42 Strohmaier Rd., Rising Sun, MD 21911.



**P.O. Box 4405
220 N. Fulton Avenue
Evansville, IN 47711**

**ORDERS : 800-523-7731
INDIANA : 812-422-0231**

the HAM STATION

 <p>ICOM R71A</p> <ul style="list-style-type: none"> • Commercial Grade Receiver • 100 kHz - 30 MHz • 32 Memories • See ICOM Ad For More Info. • Call For Discount Price 	 <p>SANGEAN RX325 803</p> <ul style="list-style-type: none"> • Direct Freq. Entry 150 kHz - 30 MHz • AC or DC • All Mode: AM/FM/CW/SSE • Programmable Memories • Call For Discount Price 	 <p>YAESU 9600</p> <ul style="list-style-type: none"> • 60-905 MHz • Optional Video Output • Now On Sale
 <p>R7000</p> <ul style="list-style-type: none"> • Commercial Receiver VHF-UHF • 25-2000 MHz • 99 Memories • Special Price, Call 	 <p>DIAMOND D130</p> <ul style="list-style-type: none"> • 25-1300 MHz Super Discone Antenna. • Transmit on 50, 144, 430, 1200 MHz • Monitor 25-1300 MHz with one antenna 	 <p>8800</p> <ul style="list-style-type: none"> • All Mode SW Receiver • 150 kHz to 30 MHz • VHF Converter Optional • Call For Price

Here's one reason why you may be missing some vital communications on your scanner.



More and more professional communications systems these days include low power portables.

Your scanner simply can't hear them without help. A professional Antenna Specialists brand monitor antenna solves the problem, effectively and permanently. Mobile or base, you can finally hear it all.

12 models available, all frequencies 25-512 MHz. Illustrated: Model MONR1 mobile VHF/UHF and Model MONR31 tri-band base antennas.

Professional monitor antennas by...

the antenna specialists co.

a member of The Allen Group Inc.



"Stripes of Quality"

12435 Euclid Avenue, Cleveland, OH 44106
Canada: A. C. Simmonds & Sons, Ltd.

CIRCLE 97 ON READER SERVICE CARD

Advertiser's Index

ARRL	66
Alpha Delta Communications	73
Antenna Specialists Co.	75
Antique Electronic Supply	74
Antique Radio Classified	43
Bary Electronics	67
Bee Electronics	23
Butternut Electronics	28
CBC International	74
CRB Research	23, 43
CTM	67
Capri Electronics	13
Cobra/Dynascan	3
Communications Electronics, Inc.	7
Deco	67
EGE, Inc.	42
Electron Processing, Inc.	57
Electronic Center, Inc.	51
Elec. Equip. Bank	35, 38, 39, 76
ENCOMM	43
Gilfer Shortwave	53
Ham Station	75
Imprime	73
Jensen Tools	67
JoGunn Ent.	31
MFJ Enterprises, Inc.	49
Madison Electronics	76
Michigan Radio	74
Microlog Corp.	31
Mission Consulting	70
Monitoring Times	15
Pacific Cable Co.	67
POP/COMM Book Shop	49
RF Limited	15
Radio West	57
Scanner World, USA	1
Scientific Radio System	59
Signal Engineering	62
Trio-Kenwood	Cov. IV
Uniden Corp. of America	Cov. II, 5
Unity Electronics	67
Universal SW Radio	73
Van Valzah Co.	36
World Tech Products	59
Yaesu Electronics	Cov. III

NEW SPORTY'S AIR-SCAN portable receiver, has 200-400 kHz longwave, 108-136 VHF, and AM and FM bands. I am selling due to poor reception in my valley location. \$50. Call (203) 621-5244.

JUST ISSUED! HEAR YOUR GOV'T. IN ACTION! The gigantic new 6th Edition of Kneitel's TOP SECRET REGISTRY OF U.S. Gov't. Radio Freqs., the ultimate scanner directory. Revised/Expanded to cover 80+ agencies, 192 large-size pages, 125,000 listings: freqs., many locations, call signs, tactical ID's, codenames, agent buzzwords, freq. usage/designator codes, code signals. Latest info: FBI, DEA, Secret Service, FCC, ATF, Immigration, Customs, Border Patrol, CIA, NSA, Nat'l. Forests, Nat'l. Parks, GSA, FEMA, Treasury, Marshals, NASA, FAA, EPA, all Armed Forces, bug/surveillance freqs., much more, plus many UHF Aero and Canadian freqs. Extra: Most important 2-25 MHz HF freqs included. Contains more and digs deeper than ever before! New 6th Ed. is \$17.95, add \$1 postage for 4th Class mail to N. American addresses, or \$3 for First Class mail. You Ain't Heard Nothin' Yet! Get your copy now: CRB Research, P.O. Box 56, Commack, NY 11725. (Dealer inquiries invited—write on company letterhead.)

POSTERS commemorating 60th anniversary of station WRC, Washington, DC. High quality 32 x 20 poster features art deco radio and is suitable for framing. A perfect addition to your shack \$20.00 plus \$2.50 shipping, mailed in a tube. SRL GRAPHICS, 77 E. 8th St., Holland, MI 49423.

MILITARY ELECTRONICS: CPRC-26 Manpack Radio, compact, transmits-receives 46-54 MHz FM, with battery box, antenna, crystal. \$17.50 apiece, \$32.50/pair. ARC-27 Guard Receiver, 220-250 MHz single channel: \$9.50. R-748 Receiver, 130-150 MHz single channel: \$22.50. Ballantine 9632A Multimeter: \$47.50 checked, \$22.50 complete/repairable. H-251 Communications Earphones: \$9.50. Patrol Seismic Intrusion Device ("PSID") TRC-3: \$42.50 apiece, \$147.50/set of four, mint condition. R-390A Communications Receiver, 5-32 MHz all modes: \$195 checked, \$115 repairable. 45-Day Replacement Guarantee. Add \$4.50/piece shipping (except R-390A, shipped collect) Baytronics, Dept. PC, Box 591, Sandusky, OH 44870.

HELP! HELP!! need to locate an antenna connector to fit a Motorola antenna to a BNC scanner. Forward info to: BNC-Motorola, 2155 Bickmore Ave., Dayton, OH 45404.

WANTED: NASCAR driver freqs used at Dover Downs Int. Speedway plus 10 codes/freqs for Delaware State/Fire. Will return postage. Gary Holton, 13119 Miles Road, Middle River, MD 21220.

SCAN Photo Contest

(from page 37)

ment, which consists of a Commodore 64, Commodore 1525E graphic printer and associated hardware. Other accessories include a Realistic Portavision, battery checker and power supply. The Bearcat 100 is connected with a BNC connector to an Avanti 801 multi-band antenna on the roof.

The large chart on the wall details the frequency allocations in Canada. Christopher says that he enjoys playing the role of "frequency detective" by spending many hours searching for new frequencies with the scanner. The computer equipment is used to keep a database of this information for the Detroit/Windsor area. He currently has 30 pages of information, and is constantly updating that list with new data.

Christopher uses several other tools in this frequency search: a calculator for determining harmonics, a microcassette recorder, and a good supply of "Post-It" notes!

Winners of the SCAN Photo Contest receive the BMI "NiteLogger" tape recorder activator. Plugged into a cassette recorder and a scanner, it provides a complete record of all communications with no "dead time" on the tape. To enter the photo contest, send a sharp black and white print to SCAN Photo Contest, P.O. Box 414, Western Springs, Illinois 60558. Don't forget to provide a complete description of the equipment your photo and some information about your scanning interests.

NEW Now In Stock **NEW**

RADIO DATABASE INTERNATIONAL

Information that every shortwave listener needs.

NEW 1987



- More than 350 pages
- At a glance: Data on every Broadcast Station in the shortwave spectrum . . . Names, Locations, Frequencies, Operating time, Language, Target area and Transmitter power . . . All displayed in a convenient easy to read frequency graph form.
- Separate cross index of major stations alphabetically by country.
- Buyer's guide to more than 50 tabletop and portable receivers by Larry Magne of World Radio TV Handbook fame.
- Reviews on all new receivers introduced during the past year.
- Antenna recommendations.

If you thought that the 1986 Radio Database International was terrific, wait until you see this brand new expanded edition. IBS has gone all out to make it the best, most useful radio listening publication available anywhere. Special while supplies last \$9.95!

1987 Radio Database International is only ~~\$12.95~~ (plus \$1.95 for shipping and handling).

TO RECEIVE YOUR COPY, SIMPLY CALL US TOLL FREE AT 800-368-3270.

ELECTRONIC EQUIPMENT BANK
 516 Mill Street, N.E.
 Vienna, VA 22180
 Order Toll Free: 800-368-3270
 Technical and VA Orders (703) 938-3350

MADISON

Call for Quotes: 1-800-231-3057
 Texas Number: 1-713-520-7300

Electronics Supply
 3621 Fannin Street, Houston, TX 77004

ICOM IC-R7000



Commercial quality scanning receiver 25-1300 MHz plus, keyboard entry, 99 memories, 5 tuning speeds. Call for \$\$\$

ANTENNAS-MADISON stocks antennas from most major antenna manufacturers.

Alpha-Delta Shortwave Sloper DX-SWL	\$63.00
Double Bazooka Coaxial Dipole, Covers Entire 10-M Band, Other Bands Available	\$29.95
AMECO New Tunable Pre-amplifier Antenna	\$69.00
McKay Dymek/DA-100D Active Antenna	\$190.00
Diamond D-130 Scanner Antenna	\$79.00
Alpha-Delta DX-SWL Slopes, 60' long, for AM BC through 13 meters	\$59.00

SPECIAL-BUTTERNUT ANTENNAS

SC-3000 30 to 512 MHz SCANNER ANT.	\$58.95
SWL DIPOLE stub tuned, low loss 2 to 30 MHz	\$44.95
HF6V 80, 40, 30, 20, 15 & 10 meter vertical	\$124.95
HF2V 80 & 40 meter vertical	\$124.95

ACCESSORIES IN STOCK . . . CALL

POLICIES: MASTERCARD—VISA—COD
 All prices FOB Houston, TX except as noted. Prices subject to change without notice, subject to prior sale. Used gear sale price refunded if not satisfied. Texas residents subject to sales tax.



Yaesu has serious listeners for the serious listener

Yaesu's serious about giving you better ways to tune in the world around you.

And whether it's for local action or worldwide DX, you'll find our VHF/UHF and HF receivers are the superior match for all your listening needs.

The FRG-9600. A premium VHF/UHF scanning communications receiver. The 9600 is no typical scanner. And it's easy to see why.

You won't miss any local action with continuous coverage from 60 to 905 MHz.

You have more operating modes to listen in on: upper or lower sideband, CW, AM wide or narrow, and FM wide or narrow.

You can even watch television programs by plugging in a video monitor into the optional video output.

Scan in steps of 5, 10, 12½, 25 and 100 KHz. Store any frequency and

CIRCLE 1 · ON READER SERVICE CARD

related operating mode into any of the 99 memories. Scan the memories. Or in between them. Or simply "dial up" any frequency with the frequency entry pad.

Plus there's more, including a 24-hour clock, multiplexed output, fluorescent readout, signal strength graph, and an AC power adapter.

The FRG-8800 HF communications receiver. A better way to listen to the world. If you want a complete communications package, the FRG-8800 is just right for you.

You get continuous worldwide coverage from 150 KHz to 30 MHz. And local coverage from 118 to 174 MHz with an optional VHF converter.

Listen in on any mode: upper and lower sideband, CW, AM wide or narrow, and FM.

Store frequencies and operating modes into any of the twelve channels for instant recall.

Scan the airwaves with a number of programmable scanning functions.

Plus you get keyboard frequency entry. An LCD display for easy readout. A SINPO signal graph. Computer interface capability for advanced listening functions. Two 24 hour clocks. Recording functions. And much more to make your listening station complete.

Listen in. When you want more from your VHF/UHF or HF receivers, just look to Yaesu. We take your listening seriously.

YAESU

Yaesu USA

17210 Edwards Road, Cerritos, CA 90701
(213) 404-2700

Yaesu Cincinnati Service Center

9070 Gold Park Drive, Hamilton, OH 45011
(513) 874-3100



Dealer inquiries invited.

Prices and specifications subject to change without notice.
FRG-9600 SSB coverage: 60 to 460 MHz.

KENWOOD

NEW

Hear it All!



R-5000

High performance receiver

THE high performance receiver is here from the leader in communications technology—the Kenwood R-5000. This all-band, all mode receiver has superior interference reduction circuits, and has been designed with the highest performance standards in mind. Listen to foreign music, news, and commentary. Tune in local police, fire, aircraft, weather, and other public service channels with the VC-20 VHF converter. All this excitement and more is yours with a Kenwood R-5000 receiver!

- **Covers 100 kHz-30 MHz in 30 bands, with additional coverage from 108-174 MHz (with VC-20 converter installed).**
- **Superior dynamic range.** Exclusive Kenwood DynaMix™ system ensures an honest 102 dB dynamic range. (14 MHz, 500 Hz bandwidth, 50 kHz spacing.)



- **100 memory channels.** Store mode, frequency, antenna selection.
- **Voice synthesizer option.**
- **Computer control option.**
- **Extremely stable, dual digital VFOs.** Accurate to ± 10 ppm over a wide temperature range.
- **Kenwood's superb interference reduction.** Optional filters further enhance selectivity. Dual noise blankers built-in.
- **Direct keyboard frequency entry.**

- **Versatile programmable scanning, with center-stop tuning.**
- **Choice of either high or low impedance antenna connections.**
- **Kenwood non-volatile operating system.** Lithium battery backs up memories; all functions remain intact even after lithium cell expires.
- **Power supply built-in.** Optional DCK-2 allows DC operation.
- **Selectable AGC, RF attenuator, record and headphone jacks, dual 24-hour clocks with timer, muting terminals.**

Optional Accessories:

- VC-20 VHF converter for 108-174 MHz operation
- YK-88A-1 6 kHz AM filter
- YK-88S 2.4 kHz SSB filter
- YK-88SN 1.8 kHz narrow SSB filter
- YK-88C 500 Hz CW filter
- YK-88CN 270 Hz narrow filter
- DCK-2 DC power cable
- HS-5, HS-6, HS-7 headphones
- MB-430 mobile bracket
- SP-430 external speaker
- VS-1 voice synthesizer
- IF-232C/IC-10 computer interface.

More information on the R-5000 and R-2000 is available from Authorized Kenwood Dealers.

R-2000 150 kHz-30 MHz in 30 bands

- All modes
- Digital VFOs tune in 50 Hz, 500 Hz, or 5 kHz steps
- 10 memory channels
- Programmable scanning
- Dual 24-hour digital clocks, with timer
- 3 built-in IF filters (CW filter optional)
- All mode squelch, noise blanker, RF attenuator, AGC switch, S meter
- 100/120/220/240 VAC operation
- Record, phone jacks
- Muting terminals
- VC-10 optional VHF converter (118-174 MHz)



Specifications and prices are subject to change without notice or obligation.

KENWOOD

KENWOOD U.S.A. CORPORATION
2201E. Dominguez St., Long Beach, CA 90810
P.O. Box 22745, Long Beach, CA 90801-5745

CIRCLE 18 ON READER SERVICE CARD